



APEX DYNAMICS, INC.

Smart Lubrication System

Technical Instruction

Original instruction





Content

I. Safety Information.....	- 1 -
I.1 Overview.....	- 1 -
I.2 Maintenance and Storage	- 1 -
I.3 Safety Regulation	- 1 -
I.4 Hazard Instruction	- 2 -
I.5 Warning Symbol.....	- 2 -
2. Lubrication Specification	- 3 -
2.1 Electrical Specification.....	- 3 -
2.2 Power and Hand-Set Connection.....	- 3 -
2.3 Outlet Position of Lubricator.....	- 4 -
2.4 Lubrication Setup Introduction.....	- 5 -
3. PLC Control.....	- 6 -
3.1 Power System Wire (PLC Control).....	- 6 -
3.1.1 Command Input Signal Wiring	- 7 -
3.2 Various Control Signal of PLC model 0.....	- 8 -
3.2.1 Model LUG-411	- 8 -
3.2.2 Model LUG-412	- 8 -
3.2.3 Model LUG-423	- 9 -
3.2.4 Model LUG-424	- 10 -
3.2.5 Model LUG-422	- 11 -
3.3 Additional Function.....	- 12 -
3.3.1 Filling of Empty Tube with Grease	- 12 -
3.3.2 Release Trapped Air	- 12 -
3.4 Lubricator Installation Procedure (PLC Mode 0 Control)	- 13 -



3.5 Lubricator Troubleshooting.....	- 14 -
3.5.1 Waveform of Grease Dispensing	- 14 -
3.5.2 Waveform Pattern of Malfunction.....	- 14 -
3.5.3 Lubricator PLC Control Output Wiring Instruction.....	- 15 -
4. Hand-Set	- 16 -
4.1 Power System Wiring (TIMER Control)	- 16 -
4.1.1 PLC Machine Power Supply	- 16 -
4.1.2 Independent Voltage Supply	- 17 -
4.2 Instruction of Hand-Set	- 18 -
4.3 Function of Hand-Set	- 19 -
4.4 Display Screen of Hand-Set	- 20 -
4.5 Procedure of Set-Up.....	- 22 -
4.6 Instruction of System Mode.....	- 25 -
4.6.1 Instruction of TIMER Mode 1	- 25 -
4.6.1.1 Model LUG-411	- 25 -
4.6.1.2 Model LUG-412.....	- 27 -
4.6.1.3 Model LUG-422.....	- 29 -
4.6.1.4 Model LUG-423	- 33 -
4.6.1.5 Model LUG-424.....	- 37 -
4.6.2 Instruction of PLC Mode 2.....	- 41 -
4.6.2.1 Model LUG-411 、 LUG-412	- 41 -
4.6.2.2 Model LUG-422 、 LUG-423 、 LUG-424.....	- 44 -
4.6.3 Clear Motor Timer Setting	- 47 -
4.6.4 Description of Error Message.....	- 49 -



- 4.6.5 Description of Output Signal Mode..... - 50 -
- 4.6.6 TIMER Mode I Control Output Wiring Instruction..... - 52 -
- 4.6.7 Clear Memory Illustration..... - 53 -
- 4.6.8 Motor Error Detective and Error Counter - 54 -
- 4.7 Lubricator Installation Procedure (TIMER mode I Control)..... - 55 -
- 4.8 Lubricator Installation Procedure (PLC mode 2 Control) - 56 -
- 4.9 Instruction of Continuous Grease Dispensing. - 57 -
- Appendix A - Lubrication Setting - 60 -
- AppendixA-1 PLC mode 0 Control..... - 60 -
- AppendixA-1-1 Model LUG-411 - 60 -
- AppendixA-1-2 Model LUG-412..... - 60 -
- AppendixA-1-3 Model LUG-423..... - 60 -
- AppendixA-1-4 Model LUG-424..... - 61 -
- AppendixA-1-5 Model LUG-422..... - 61 -
- AppendixA-2 TIMER mode I Control..... - 62 -
- AppendixA-2-1 Model LUG-411 - 62 -
- AppendixA-2-2 Model LUG-412..... - 62 -
- AppendixA-2-3 Model LUG-423..... - 63 -
- AppendixA-2-4 Model LUG-424..... - 63 -
- AppendixA-2-5 Model LUG-422..... - 63 -
- AppendixA-3 PLC mode 2 Control..... - 64 -
- AppendixA-3-1 Model LUG-411 - 64 -
- AppendixA-3-2 Model LUG-412..... - 64 -
- AppendixA-3-3 Model LUG-423..... - 64 -
- AppendixA-3-4 Model LUG-424..... - 65 -



AppendixA-3-5 Model LUG-422..... - 65 -

Appendix B - Replacing New Cartridge - 66 -

 Appendix B-1 New Cartridge Replacing - 66 -

 Appendix B-2 Empty cartridge refill oil again. - 68 -

Appendix C- Lubricator Explosion Proof Specification..... - 71 -

 Appendix C-1 side view and power cable wire connect description..... - 71 -

 Appendix C-2 Maintenance and Storage - 72 -

Manual name	Manual No.
Smart Lubrication System Technical Instruction	LUG400190529-01



I. Safety Information

I.1 Overview

All personnel must read the entire manual instructions carefully and ensure full understanding the contents before operating, installing and maintaining the SMART Lubrication System. This is to avoid unnecessary danger during smooth operation.

Lubrication System only can be used on pinion or linear guide, it is prohibited for other applications. APEX DYNAMIC can not take the responsibility for the damage under those abnormal usage.

I.2 Maintenance and Storage

- Turn off the power during maintenance and suggest wear gloves and goggles
- Store lubrication system into circulated freely environment
- The grease should be stored in sealed barrel and fix the storage position under room temperature environment
- Avoiding storage in process region, high temperature surface, splashing liquid or on the electrical devices. And consider the suitability for replacement
- Make sure screw the plug on both hand-set and oil cup when lubricator is stop working
- Avoiding inject the prohibitive oil/grease into the lubricator
- Use the funnel or assistant tool when inject the oil into the lubricator to avoid oil leakage to ground or equipment that cause the accident

I.3 Safety Regulation

Please do not ignore Safety Regulation which may cause unnecessary injury or loss of company asset. APEX will not be liable for following situations:

- Incorrect assembly and failure to comply with method of installation, operation, setting-up, maintenance, repair, may result in danger.
- Self-Disassembly of Lubricator
- Self-Modification of Lubricator
- Using Unsuitable Grease
- Using Non-Original Manufacturer Part
- Performing Incorrect method of Trouble shooting error



1.4 Hazard Instruction

The Hazard warning is defined as four types of danger level:



Danger refer to hazards with a high risk of severe physical injury or immediate fatality



Warning refers to hazards with moderate risk of severe physical injury or potential fatality.



Caution refers to hazards with a low risk of moderate physical injury.



Note refers to hazards with a slight risk of moderate physical injury.

1.5 Warning Symbol

All users must pay attention to the symbols of Hazard warnings mentioned in Manual as shown in table:

Symbol	Explanation of Symbols
	Hazards due to general causes
	Hazards due to dangerous electrical voltage
	Hazards due to environment pollution
	Wear personal protective equipment (Gloves)
	Wear personal protective equipment (Goggles)



2. Lubrication Specification

2.1 Electrical Specification

Input Power	DC24V ± 4%
Power Consumption	12W max
Operating Current	I max ≤ 500mA
Output / Input	Status Output I Set; Command Input ISet
Status Output Max. Current	100mA
Command Input Max. Current	50mA
Operating Temperature	-25~70 C
Control mode	PLC mode 0、TIMER mode 1、PLC mode 2

Note: Herewith mode 0 and mode 2 which can be controlled by PLC, the original setup is PLC mode 0. Request Hand-Set connection if needs to change the mode.

2.2 Power and Hand-Set Connection

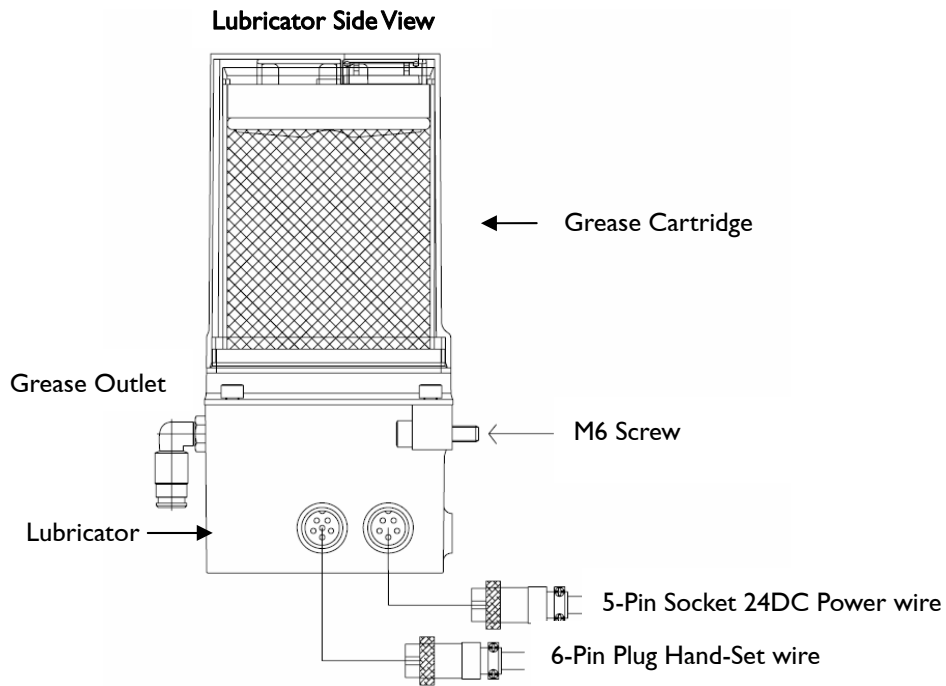

6-Pin Plug (Hand-Set Wire)



- 1. Output DC 24V
- 2. GND
- 3. I_BUSY/
- 4. RS485
- 5. RS485/

5-Pin Socket (Power Wire)

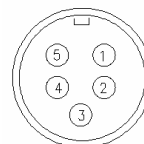

- 1. Output Signal
- 2. Input Signal
- 4. Input DC 24V
- 5. GND

6-Pin Socket on Lubricator



5-Pin Plug on Lubricator

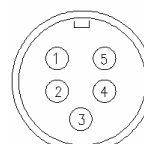



2.3 Outlet Position of Lubricator

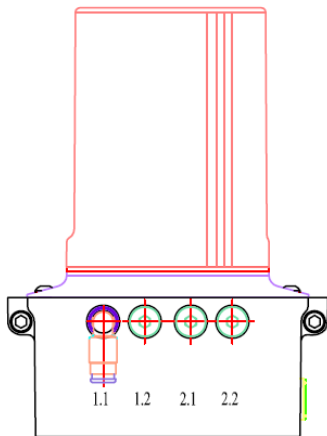

LUG-411

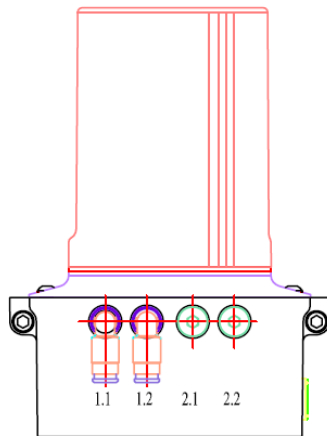

LUG-412

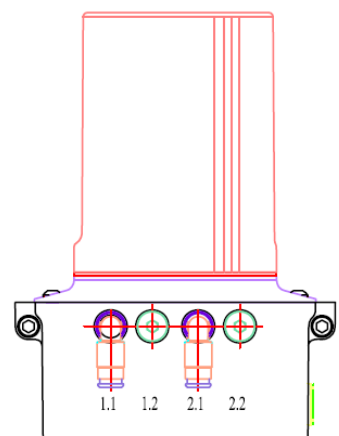

LUG-422

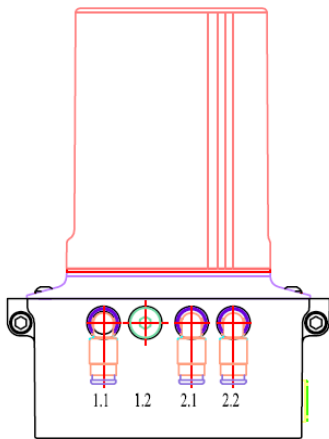

LUG-423

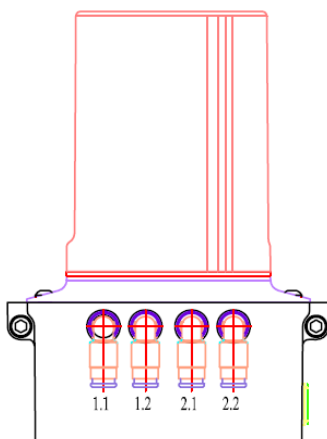

LUG-424

LUG-411:

1.1 Outlet : per stroke 0.15cm^3
Other Oil Outlet is sealed.

LUG-412:

1.1 Outlet : per stroke 0.15cm^3
1.2 Outlet : per stroke 0.15cm^3
Other Oil Outlet is sealed.

LUG-422:

1.1 Outlet : per stroke 0.15cm^3
1.2 Outlet : Outlet is sealed.
2.1 Outlet : per stroke 0.15cm^3
2.2 Outlet : Outlet is closed.

LUG-423:

1.1 Outlet : per stroke 0.15cm^3
1.2 Outlet : Outlet is sealed.
1.1 Outlet : per stroke 0.15cm^3
1.2 Outlet : per stroke 0.15cm^3

LUG-424:

1.1 Outlet : per stroke 0.15cm^3
1.2 Outlet : per stroke 0.15cm^3
1.1 Outlet : per stroke 0.15cm^3
1.2 Outlet : per stroke 0.15cm^3



2.4 Lubrication Setup Introduction

APEX DYNAMIC, INC. provide the 2 pcs M6 screws and 2 pcs washer for installation. Be aware to install the lubricator in sufficient brightness with well circulated freely environment. And avoid to storage in process region, high temperature surface, splashing liquid or on the electrical devices, also consider the suitability for replacement. Moreover, the tube installation should compatible with system and PLC machine safety standard.

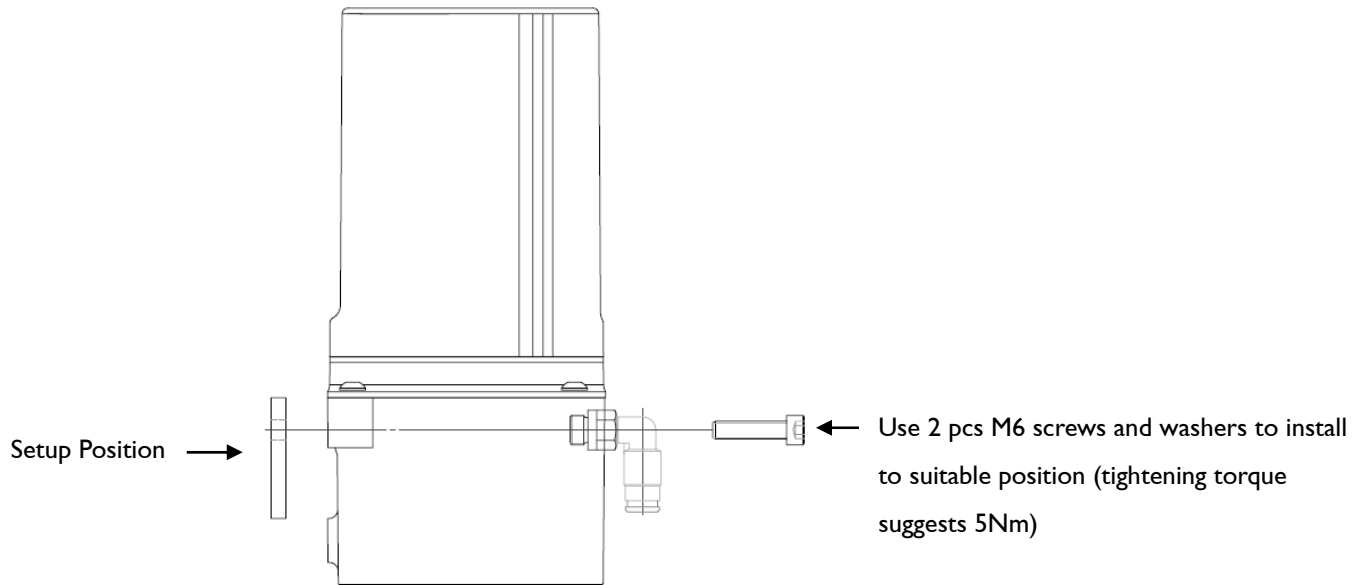



3. PLC Control

PLC transfer different output control signals to Lubricator power plug PIN 2, this can control function of lubricator greasing action, delivered grease volume. The control signal of the Lubricator PLC can be divided into 2 molds as mode 0 and mode 2, the Chapter 3 focuses on mode 0, Mode 2 control signals can refer in section 4.6.2.

3.1 Power System Wire (PLC Control)

 **Caution**



APEX provide the power connector, and the user can use the suitable wire to match the connector bore and application. The current resistance at least 1.5A.

The isolation transformer or power supply can produce output DC 24V under control of PLC machine and provided Lubricator with required power DC 24V.

 **Warning**

The isolation transformer or power supply should be certificated product, to avoid the risk of electric shock to the user or equipment

Wiring Diagram of Power System

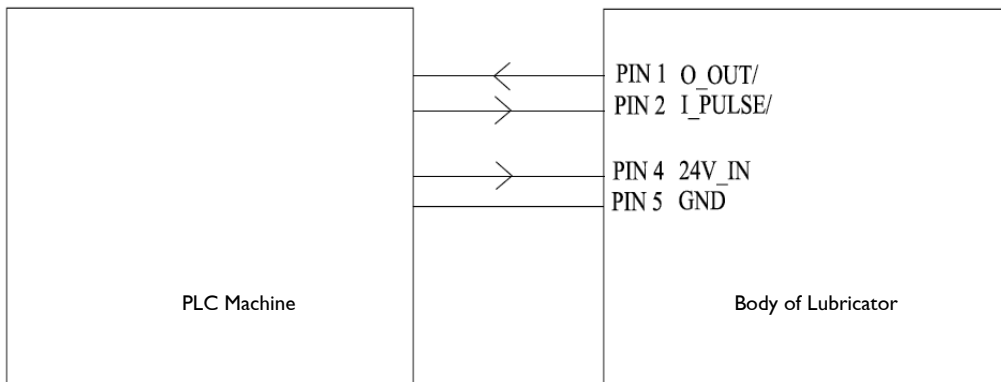

Circuit Protection Switch
(Fuse), Rated Current = 1.1A

 **Caution**



When the input voltage of Lubricator is higher than specified voltage, this will cause damage to the lubricator.



3.1.1 Command Input Signal Wiring

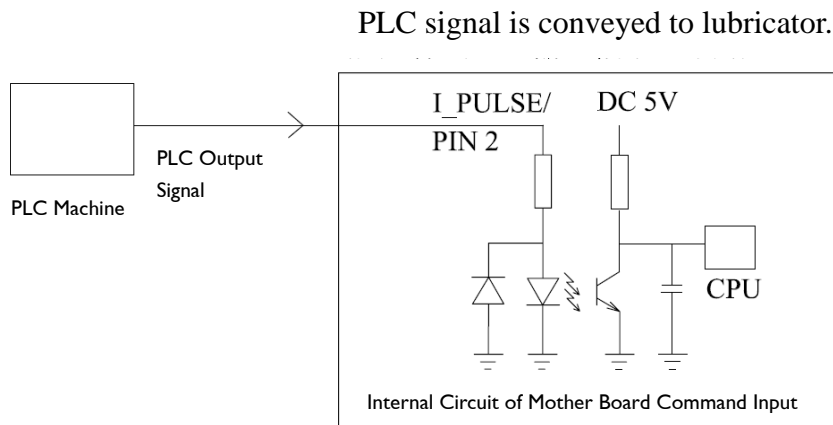

Lubricant Input Electrical Specifications

Input
Rated Voltage : DC 24V ,
Rated Current : 50mA



3.2 Various Control Signal of PLC model 0

Each Lubrication model has control signal and mechanism as illustrated below, LOW as 0V and high as 24V Signal.

3.2.1 Model LUG-411

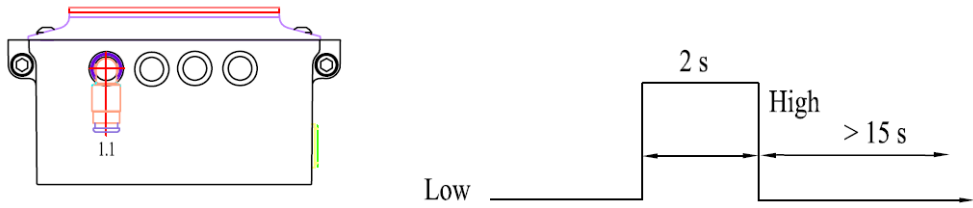

Pump 1 pushed 1 stroke to outlet 1.1 dispensing 0.15cm^3 of grease when Lubricator received one 2s HIGH signal.

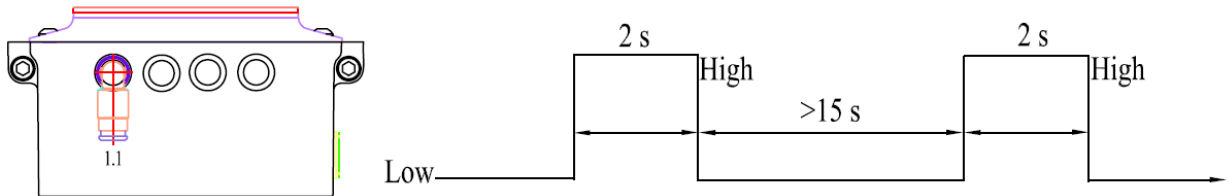

Pump 1 pushed 2 strokes to outlet 1.1 dispensing 2 strokes of 0.15cm^3 of grease (total 0.3cm^3 grease) when Lubricator received two 2s HIGH signal. Ensure cycle intervals of two 2s HIGH signal are 15s.

3.2.2 Model LUG-412

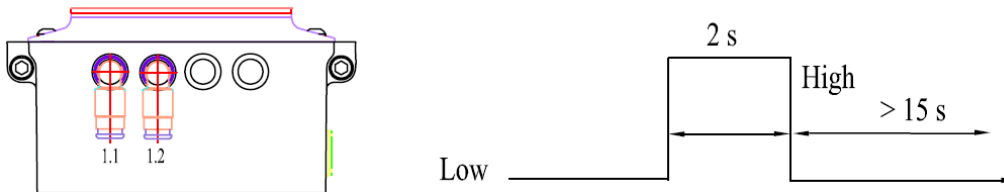

Pump 1 pushed 1 stroke to outlet 1.1 or 1.2 dispensing 0.15cm^3 of grease when Lubricator received one 2s HIGH signal.

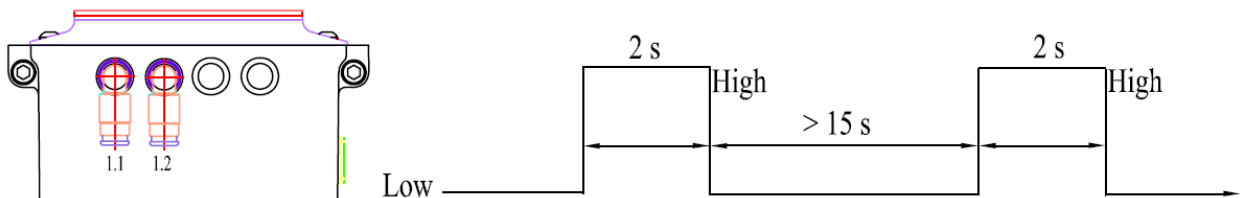

Pump 1 pushed 1 stroke to each outlet 1.1 and 1.2 dispensing 0.15cm^3 of grease when Lubricator received two 2s HIGH signal. Ensure cycle intervals of two 2s HIGH signal are 15s.



3.2.3 Model LUG-423

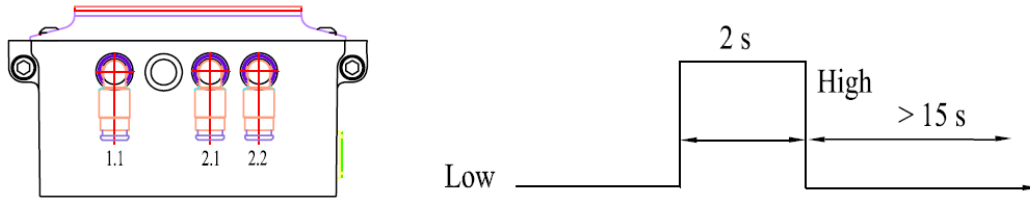

Pump 1 pushed 1 stroke to outlet 1.1 dispensing 0.15cm^3 of grease when Lubricator received one 2s HIGH signal.

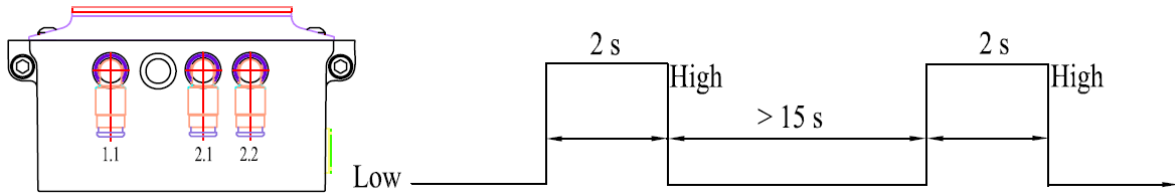

Pump 1 pushed 2 strokes to outlet 1.1 dispensing 2 strokes of 0.15cm^3 of grease (total 0.3cm^3 grease) when Lubricator received two 2s HIGH signal. Ensure cycle intervals of two 2s HIGH signal are 15s.

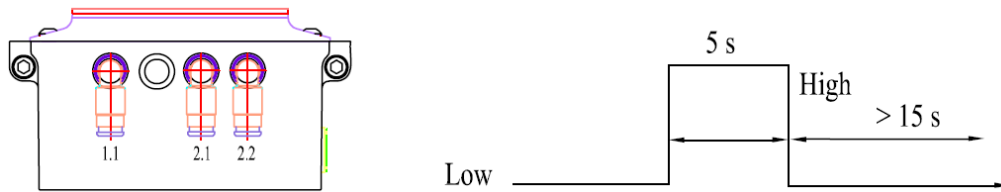

Pump 2 pushed 1 stroke to outlet 2.1 or 2.2 dispensing 0.15cm^3 of grease when Lubricator received one 5s HIGH signal.

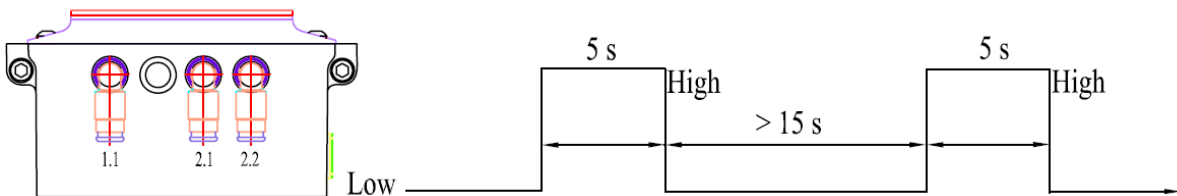

Pump 2 pushed 1 stroke to each outlet 2.1 and 2.2 dispensing 0.15cm^3 of grease when Lubricator received two 5s HIGH signal. Ensure cycle intervals of two 5s HIGH signal are 15s.

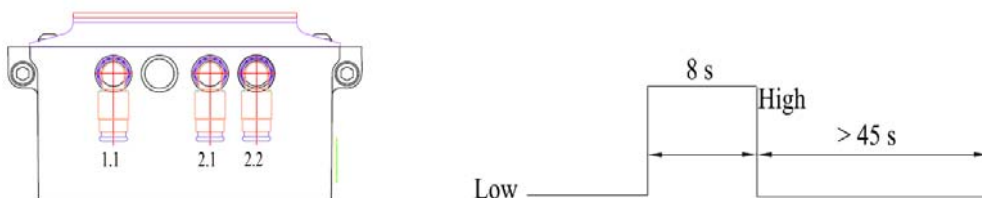

Pump 1 pushed 1 stroke to outlet 1.1, 2.1 and 2.2 dispensing 0.15cm^3 of grease when Lubricator received one 8s HIGH signal.



3.2.4 Model LUG-424

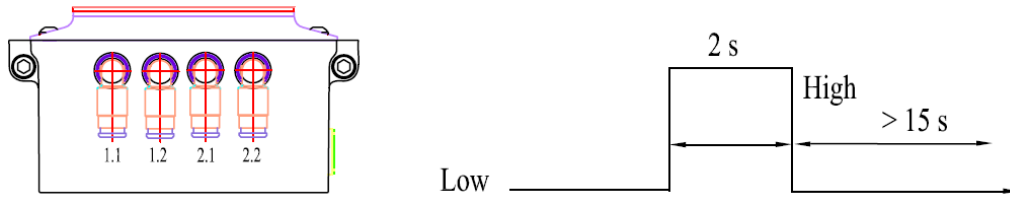

Pump 1 pushed 1 stroke to outlet 1.1 or 1.2 dispensing 0.15cm³ of grease when Lubricator received one 2s HIGH signal.

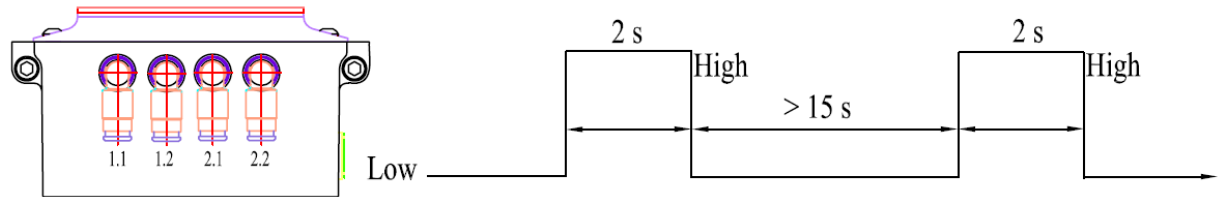

Pump 1 pushed 1 stroke to each outlet 1.1 and 1.2 dispensing 0.15cm³ of grease when Lubricator received two 2s HIGH signal. Ensure cycle intervals of two 2s HIGH signal are 15s.

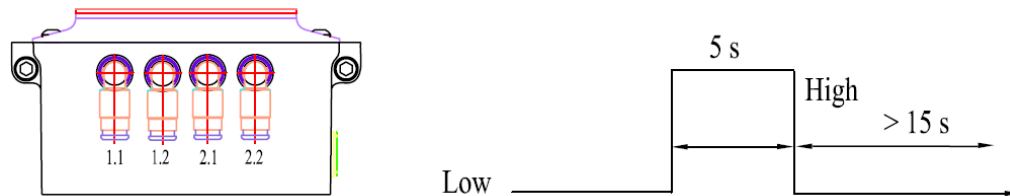

Pump 2 pushed 1 stroke to outlet 2.1 or 2.2 dispensing 0.15cm³ of grease when Lubricator received one 5s HIGH signal.

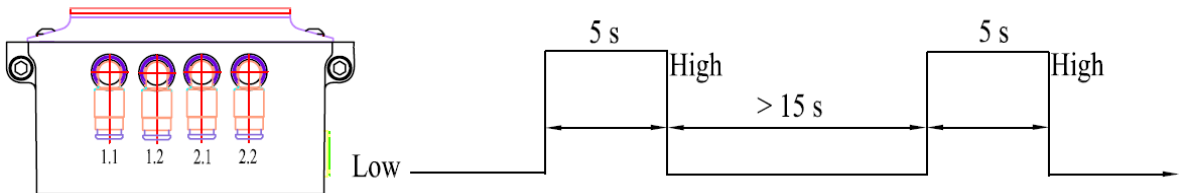

Pump 2 pushed 1 stroke to each outlet 2.1 and 2.2 dispensing 0.15cm³ of grease when Lubricator received two 5s HIGH signal. Ensure cycle intervals of two 5s HIGH signal is 15s.

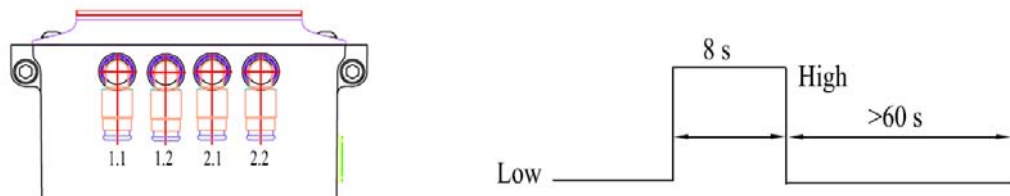

Pump 1 & Pump 2 pushed 1 stroke to each outlet 1.1, 1.2, 2.1 and 2.2 dispensing 0.15cm³ of grease when Lubricator received one 8s HIGH signal.



3.2.5 Model LUG-422

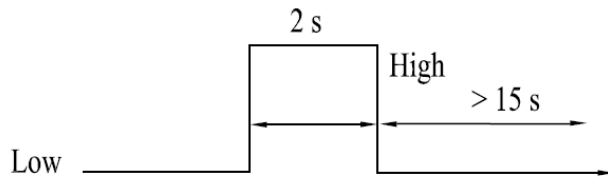
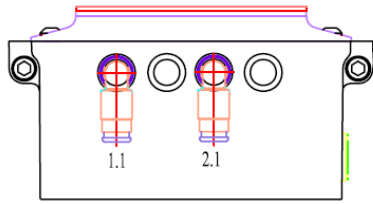

Pump 1 pushed 1 stroke to outlet 1.1 dispensing 0.15cm^3 of grease when Lubricator received one 2s HIGH signal.

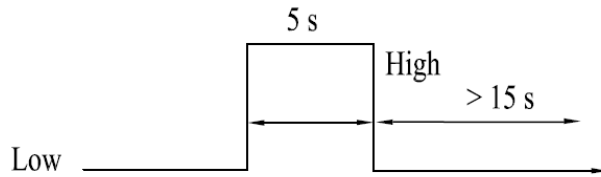
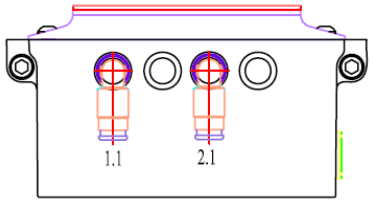

Pump 2 pushed 1 stroke to outlet 2.1 dispensing 0.15cm^3 of grease when Lubricator received one 5s HIGH signal.

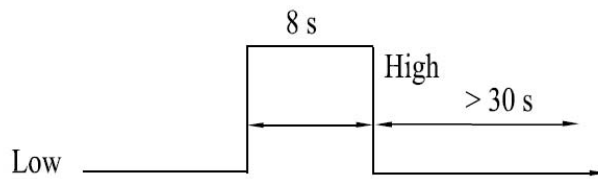
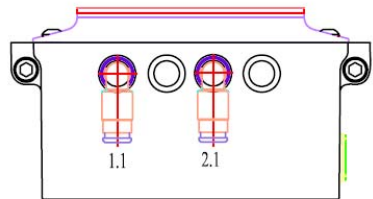

Pump 1 and Pump 2 pushed 1 stroke to each outlet 1.1 and 2.1 dispensing 0.15cm^3 of grease when Lubricator received one 8s HIGH signal.



3.3 Additional Function

3.3.1 Filling of Empty Tube with Grease

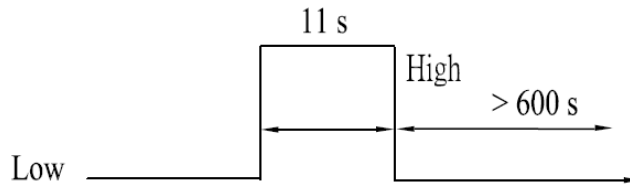

May use PLC output I Is HIGH signal after completed installing Lubricator Tube to perform greasing continuously and user use this function to allow empty tube filled with grease. After receiving the PLC signal of each Lubricator model, volume of grease supply to each outlet as follows:

LUG-411:

1.1 Outlet : $10 \times 0.15\text{cm}^3 = 1.5\text{cm}^3$

LUG-412:

1.1 Outlet : $10 \times 0.15\text{cm}^3 = 1.5\text{cm}^3$

1.2 Outlet : $10 \times 0.15\text{cm}^3 = 1.5\text{cm}^3$

LUG-422:

1.1 Outlet : $10 \times 0.15\text{cm}^3 = 1.5\text{cm}^3$

2.1 Outlet : $10 \times 0.15\text{cm}^3 = 1.5\text{cm}^3$

LUG-423:

1.1 Outlet: $10 \times 0.15\text{cm}^3 = 1.5\text{cm}^3$

2.1 Outlet: $10 \times 0.15\text{cm}^3 = 1.5\text{cm}^3$

2.2 Outlet: $10 \times 0.15\text{cm}^3 = 1.5\text{cm}^3$

LUG-424:

1.1 Outlet : $10 \times 0.15\text{cm}^3 = 1.5\text{cm}^3$

1.2 Outlet : $10 \times 0.15\text{cm}^3 = 1.5\text{cm}^3$

2.1 Outlet : $10 \times 0.15\text{cm}^3 = 1.5\text{cm}^3$

2.1 Outlet : $10 \times 0.15\text{cm}^3 = 1.5\text{cm}^3$

All models have the same oil outlet $10 \times 0.15\text{cm}^3 = 1.5\text{cm}^3$

3.3.2 Release Trapped Air

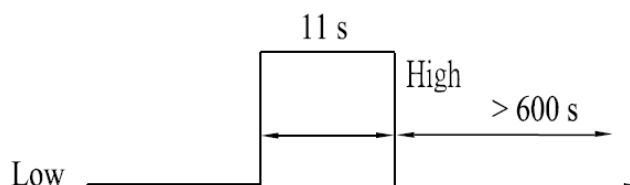

May use PLC output I Is HIGH signal to perform greasing continuously and remove trapped air in internal tube.



3.4 Lubricator Installation Procedure (PLC Mode 0 Control)

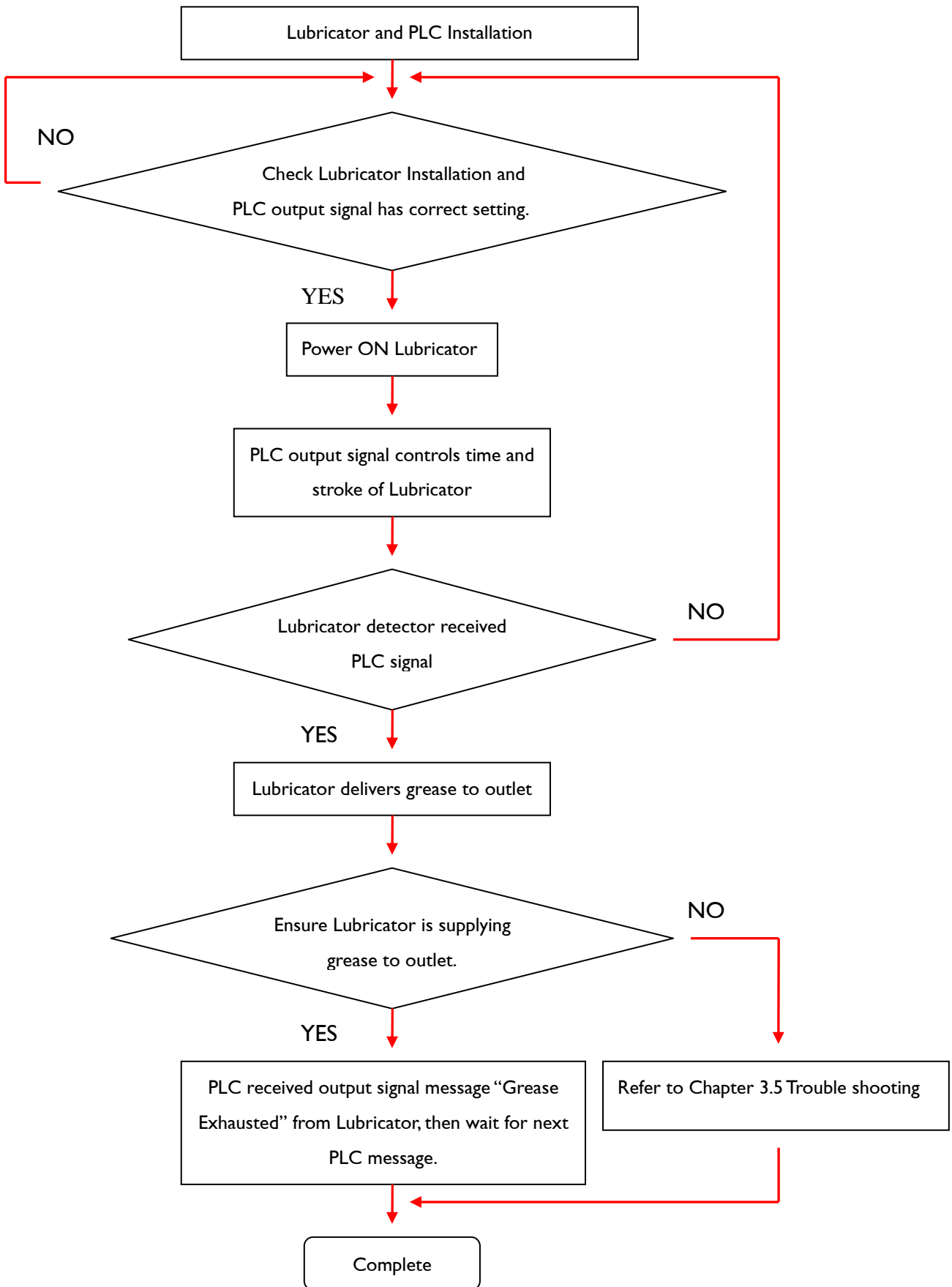



3.5 Lubricator Troubleshooting

PIN 1 of Lubricator power supply connected to PLC machine, the PIN will output different signal to PLC so that PLC knows status of lubricator. Lubricator output signal with the corresponding information as follows Displaying 0V signal as LOW, 24V signal as HIGH.

3.5.1 Waveform of Grease Dispensing



Power ON Lubricator, PIN 1 output signal as HIGH, at this time Lubricator then will receive the PLC command.

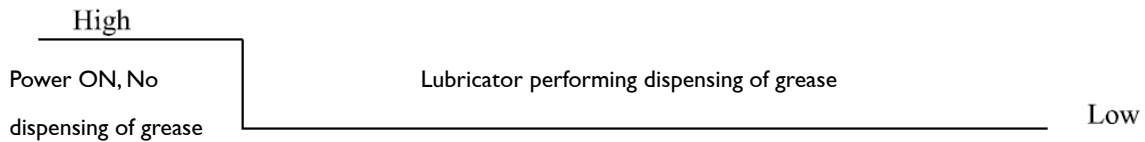

When Pin 1 output signal changed from HIGH to LOW, this means PLC knows Lubricator is performing dispensing of grease to outlet and at this moment Lubricator will ignore PLC command.

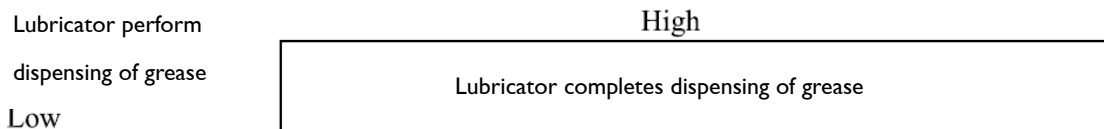

When Pin 1 output signal change from LOW to HIGH, this means PLC knows Lubricator completes dispensing of grease to outlet.

3.5.2 Waveform Pattern of Malfunction



Lubricator malfunction, PIN 1 will continue to output LOW signal, at this time please follow the table for Lubricator troubleshooting.



Malfunction	Reason	Remedy
Lubricator cannot dispense grease	PA tube filled with grease contains trapped air	Refer 3.3 for trouble shooting
	Lubricator PA tube blocked	Inspect PA tube for foreign particle blockage or tube length is too long.
	Lubricator motor idling	Contact Manufacturer

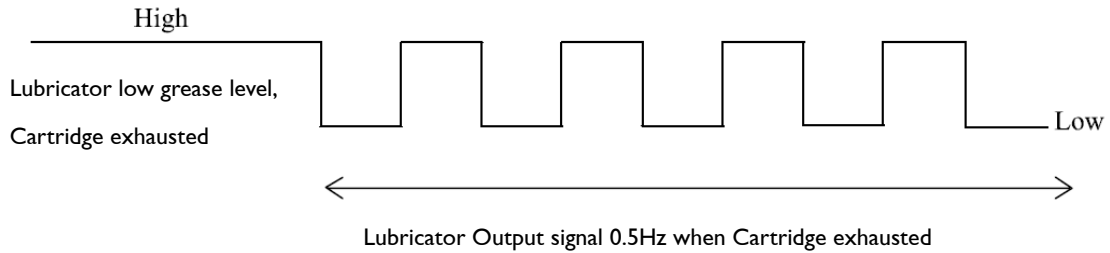

Please follow the table for troubleshooting when Lubricator cartridge is exhausted, PIN 1 will send output 0.5Hz signal.

Malfunction	Reason	Solution
Lubricator cannot dispense grease	Black Sensor plate reaches low grease level detection zone, Cartridge exhausted	Refer to APPENDIX B for replacement of a new grease Cartridge.

3.5.3 Lubricator PLC Control Output Wiring Instruction

Wiring of Lubricator Output signal to the PLC machine.

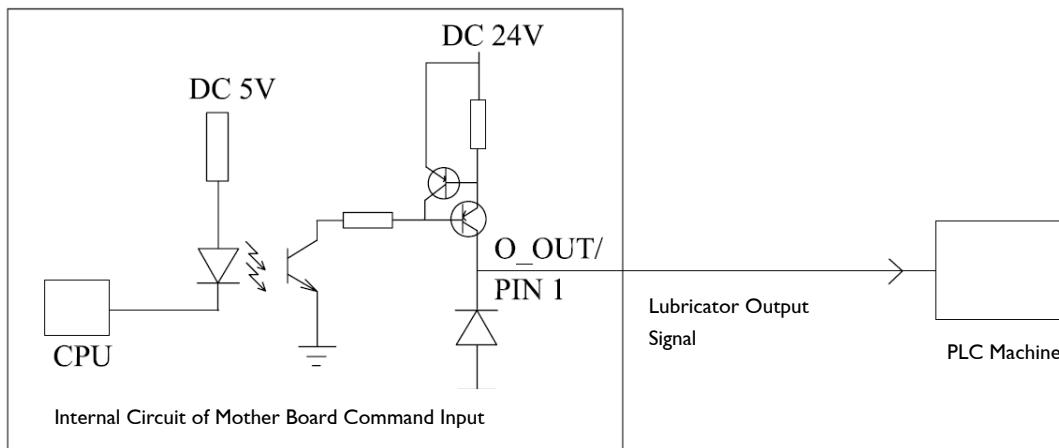

Lubricator Output Electrical Specification

Rated Voltage : DC 24V
Maximum Output Current : 100mA



4. Hand-Set

APEX developed the Lubricator Hand-Set controller to perform regular routine grease supply function and real-time feedback to Hand-Set informing user Lubricator current status so no need to go through PLC transfer signal to achieve target.

4.1 Power System Wiring (TIMER Control)

Hand-Set of Lubricator requires DC24V power from PLC machine or independent power source.



APEX provide the power connector, and the user can use the suitable wire to match the connector bore and application. The current resistance at least 1.5A.

4.1.1 PLC Machine Power Supply

Power supply system Wiring diagram

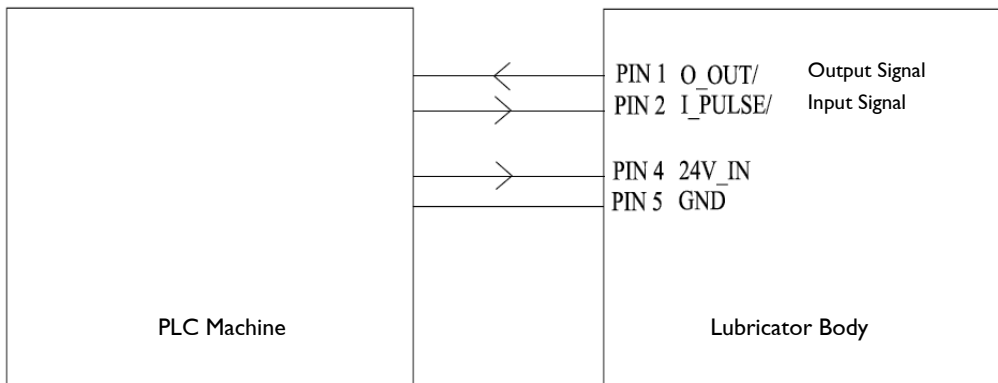

Circuit Protection Switch
(Fuse). Rated Current = 1.1A



4.1.2 Independent Voltage Supply

Lubricator can use PLC machine and also install an independent voltage source for power supply. The independent voltage source can be a power supply device, converting Single-Phase AC 110V / 220V, 50 / 60Hz to DC 24V. During the installation, the input side of power supply should include a circuit protection with no fuse breaker

Power System Wiring diagram

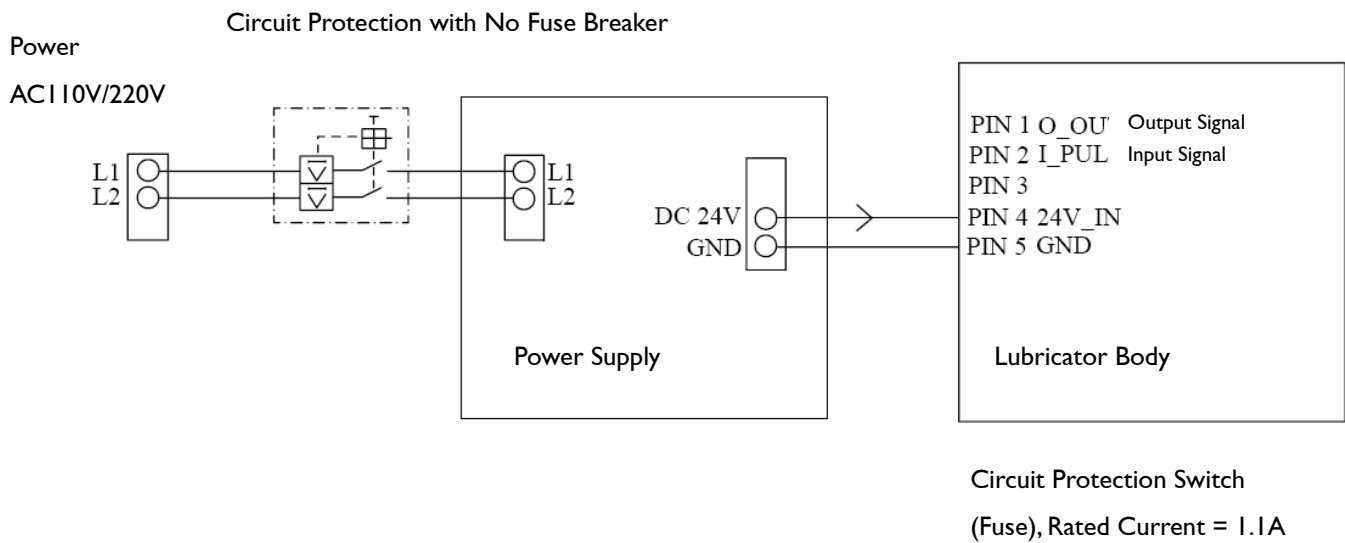

 **Warning**



When the input voltage of Lubricator is higher than specified voltage, this will cause damage to the lubricator.



4.2 Instruction of Hand-Set

Lubricator Hand-Set has a User-Friendly Interface Design, and simple features to allow user to quickly install, operate, and edit functions according to user needs, a brief overview are as follows:

- Setting of Lubricator timing and greasing frequency
- Both display screen symbol & Key pad are same.
- Self-Monitoring system (While operating, fault / error can be detected anytime to avoid damage.)
- All parameters stored in EEPROM (No loss of stored data when power is OFF)



Note







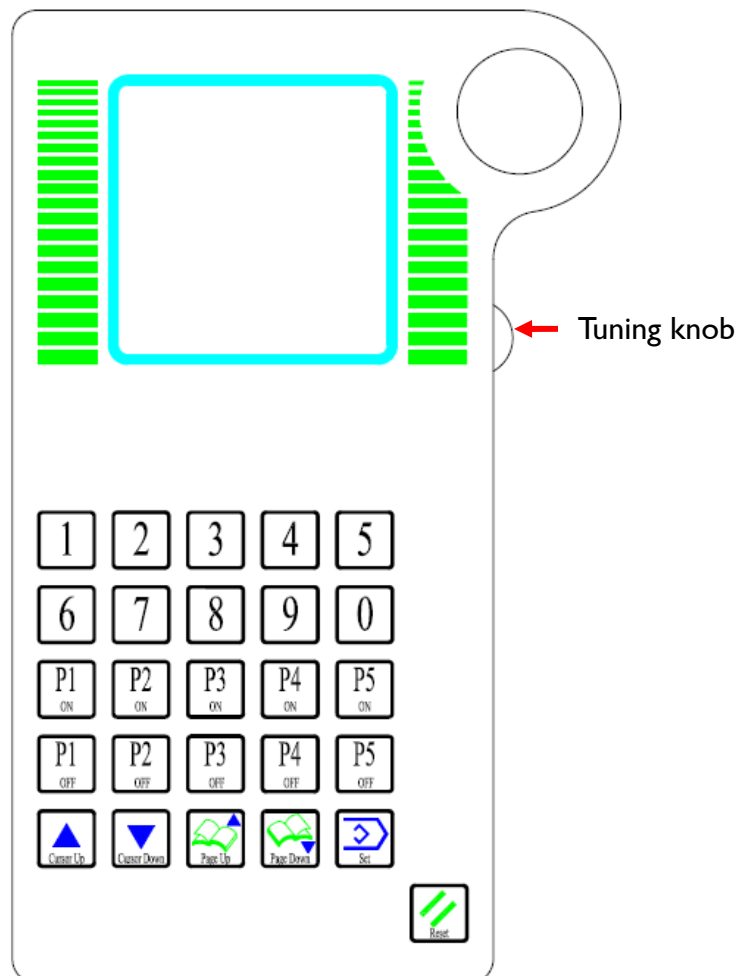





















For Hand-Set setting, APEX defined Pump P1 Grease supply outlets as 1.1 and 1.2; Pump P2 Grease supply outlets as 2.1 and 2.2.

Hand-Set Top View



























4.3 Function of Hand-Set

	Numerical Key1		Set
	Numerical Key2		System Reset
	Numerical Key3		Pump 1 continuous dispensing
	Numerical Key4		Pump 2 continuous dispensing
	Numerical Key5		Pump 3 function only LUG-2000
	Numerical Key6		Pump 3 function only LUG-2000
	Numerical Key7		Pump 3 function only LUG-2000
	Numerical Key8		Pump 1 stop dispensing
	Numerical Key9		Pump 2 stop dispensing
	Numerical Key0		Pump 3 function only LUG-2000
	Cursor Up		Pump 4 function only LUG-2000
	Cursor Down		Pump 5 function only LUG-2000
	Page Up	Tuning knob	Adjust the screen brightness
	Page Down		



4.4 Display Screen of Hand-Set

<p style="text-align: center;">S1</p> <div style="border: 1px solid black; padding: 10px; text-align: center;">  <p>APEX DYNAMICS, INC. Key in password : **** M:1.00 T:1.00 Press  to confirm</p> </div>	<p style="text-align: center;">S5</p> <div style="border: 1px solid black; padding: 10px;"> <p>Clear motor timer: 0 Operating code use: 0 Operating code: 1 2 3 4</p> <p style="text-align: center;"> page up  page down</p> </div>	<p style="text-align: center;">S9</p> <div style="border: 1px solid black; padding: 10px;"> <p>P1 ADC parameter: 00 P2 ADC parameter: 00</p> <p style="text-align: center;">Unauthorized setting prohibition</p> </div>
<p style="text-align: center;">S2</p> <div style="border: 1px solid black; padding: 10px;"> <p>Mode Selection : 0 0:PLC 1:TIMER 2::PLC P1 cycle : 000 days 00 hours 00 minutes P1 motion : 01 times P2 cycle : 000 days 00 hours 00 minutes P2 motion : 01 times</p> <p style="text-align: center;"> page up  page down</p> </div>	<p style="text-align: center;">S6</p> <div style="border: 1px solid black; padding: 10px;"> <p style="text-align: center;">Error message 1-5</p> <p style="text-align: center;"> page up  page down</p> </div>	<p style="text-align: center;">S10</p> <div style="border: 1px solid black; padding: 10px;"> <p>Power voltage: 24.0 P1 cycle and timer : cycle: 000001 Timer: 0000001 P2 cycle and timer : cycle: 000001 Timer: 0000001</p> <p style="text-align: center;">1.1 operating</p> <p style="text-align: center;"> page up  page down</p> </div>
<p style="text-align: center;">S3</p> <div style="border: 1px solid black; padding: 10px;"> <p>Power voltage: 24.0 P1 cycle and timer : cycle: 000001 Timer: 0000001 P2 cycle and timer : cycle: 000001 Timer: 0000001</p> <p style="text-align: center;"> page up  page down</p> </div>	<p style="text-align: center;">S7</p> <div style="border: 1px solid black; padding: 10px;"> <p style="text-align: center;">Error message 6-10</p> <p style="text-align: center;"> page up  page down</p> </div>	<p style="text-align: center;">S11</p> <div style="border: 1px solid black; padding: 10px;"> <p>Power voltage: 24.0 P1 cycle and timer : cycle: 000001 Timer: 0000001 P2 cycle and timer : cycle: 000001 Timer: 0000001</p> <p style="text-align: center;">1.2 operating</p> <p style="text-align: center;"> page up  page down</p> </div>
<p style="text-align: center;">S4</p> <div style="border: 1px solid black; padding: 10px;"> <p>Language Display(語 文版本): 1 0:English(英文) 1:Chinese(中文)</p> <p style="text-align: center;"> page up  page down</p> </div>	<p style="text-align: center;">S8</p> <div style="border: 1px solid black; padding: 10px;"> <p>Output signal mode: 0 Clear memory : 0 Error detective : 0 Error counter : 01 Operating mode : 00</p> <p style="text-align: center;"> page up  page down</p> </div>	<p style="text-align: center;">S12</p> <div style="border: 1px solid black; padding: 10px;"> <p>Power voltage: 24.0 P1 cycle and timer : cycle: 000001 Timer: 0000001 P2 cycle and timer : cycle: 000001 Timer: 0000001</p> <p style="text-align: center;">2.1 operating</p> <p style="text-align: center;"> page up  page down</p> </div>



S13	S17	S21
<p>Power voltage: 24.0 P1 cycle and timer : cycle: 000001 Timer: 0000001 P2 cycle and timer : cycle: 000001 Timer: 0000001</p> <p>2.2 operating</p> <p>⏪page up⏩page down</p>	<p>Power voltage: 24.0 P1 cycle and timer : cycle: 000001 Timer: 0000001 P2 cycle and timer : cycle: 000001 Timer: 0000001</p> <p>Motor2 or pipe block</p> <p>⏪page up⏩page down</p>	<p>Power voltage: 24.0 P1 cycle and timer : cycle: 000001 Timer: 0000001 P2 cycle and timer : cycle: 000001 Timer: 0000001</p> <p>INVALID COMMAND</p> <p>⏪page up⏩page down</p>
S14	S18	S22
<p>Power voltage: 24.0 P1 cycle and timer : cycle: 000001 Timer: 0000001 P2 cycle and timer : cycle: 000001 Timer: 0000001</p> <p>PI motor idling</p> <p>⏪page up⏩page down</p>	<p>Power voltage: 24.0 P1 cycle and timer : cycle: 000001 Timer: 0000001 P2 cycle and timer : cycle: 000001 Timer: 0000001</p> <p>Grease exhausted</p> <p>⏪page up⏩page down</p>	<p>Power voltage: 24.0 P1 cycle and timer : cycle: 000001 Timer: 0000001 P2 cycle and timer : cycle: 000001 Timer: 0000001</p> <p>Use in timer mode</p> <p>⏪page up⏩page down</p>
S15	S19	S23
<p>Power voltage: 24.0 P1 cycle and timer : cycle: 000001 Timer: 0000001 P2 cycle and timer : cycle: 000001 Timer: 0000001</p> <p>P2 motor idling</p> <p>⏪page up⏩page down</p>	<p>Power voltage: 24.0 P1 cycle and timer : cycle: 000001 Timer: 0000001 P2 cycle and timer : cycle: 000001 Timer: 0000001</p> <p>Memory reading error</p> <p>⏪page up⏩page down</p>	<p>Mode Selection : 0 0:PLC 1:TIMER 2::PLC P1 cycle : 00 days 00 hours 00 minutes P1 motion : 01 times P2 cycle : 00 days 00 hours 00 minutes P2 motion : 01 times</p> <p>RANGE I~99</p> <p>⏪page up⏩page down</p>
S16	S20	
<p>Power voltage: 24.0 P1 cycle and timer : cycle: 000001 Timer: 0000001 P2 cycle and timer : cycle: 000001 Timer: 0000001</p> <p>Motor I or pipe block</p> <p>⏪page up⏩page down</p>	<p>Power voltage: 24.0 P1 cycle and timer : cycle: 000001 Timer: 0000001 P2 cycle and timer : cycle: 000001 Timer: 0000001</p> <p>Memory writing error</p> <p>⏪page up⏩page down</p>	



4.5 Procedure of Set-Up

S1



S1 screen will display on Hand-Set when connected to power of lubricator; enter password to go to next setting.

S2



Press Set

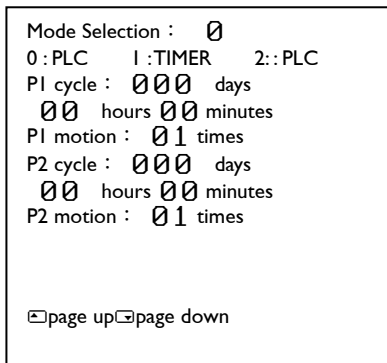

1. Select Mode: Setting the lubricator control mode, 0 is the PLC mode 0 control. For details, please refer to Chapter 3: 1 is TIMER mode 1 control. detailed description refer to "Section 4.6.1". 2 is PLC mode 2 control, detailed description refer "Section 4.6.2". When setting mode 0 or mode 2, P1, P2 action override and period, the parameter value cannot be set.

2. P1 Cycle: Set P1 Cycle Time to begin supply Grease at Outlet. 1.1 or 1.2

3. P1 Motion: Set P1 motion 1 stroke per outlet dispenses 0.15cm³ after countdown of P1 cycle time.

4. P2 Cycle: Set P2 Cycle Time to begin supply Grease at Outlet. 2.1 or 2.2

5. P2 Motion: Set P2 motion 1 stroke per outlet dispenses 0.15cm³

S3



Press Page down

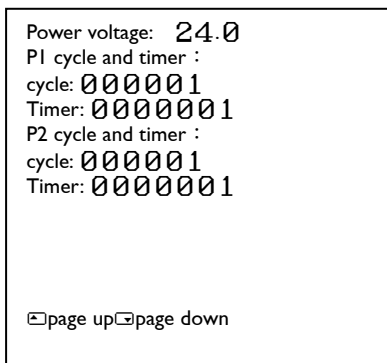

1. Input Voltage: Displays 24V direct current supply to Lubricator

2. P1 Cycle: Displays total no. of strokes for P1 current Greasing status.

3. P1 Timer: Displays countdown of P1 setting time (minutes) before deliver grease to outlet.

4. P2 Cycle: Displays total no. of strokes for P2 current Greasing status.

5. P2 Timer: Displays countdown of P2 setting time (minutes) before deliver grease to outlet.



Press Page down



S4

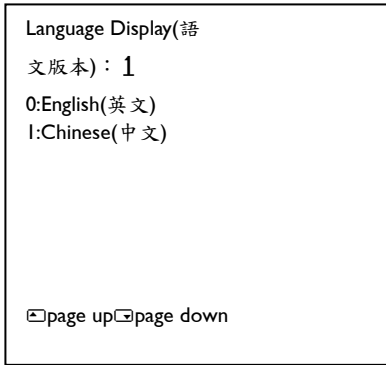

Hand-Set Language display setting key 0 for English or 1 for Chinese then press SET.



S5

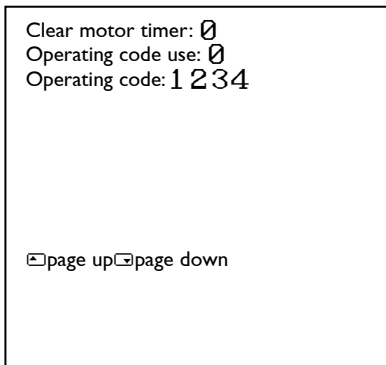

1. Clear motor timer records:

Press Set 1 to display total no. of strokes records for Pump 1 and Pump 2. Set 0 to Clear records.

2. Operating Code:

Press Set 1 to activate and 0 as inactive.

3. Modify Code:

Press Set 1 to modify the password.



Press Page down

S6

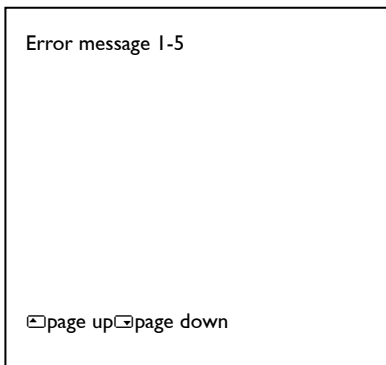

Frequent Error message history records from Items 1 to 5.



Press Page down



S7

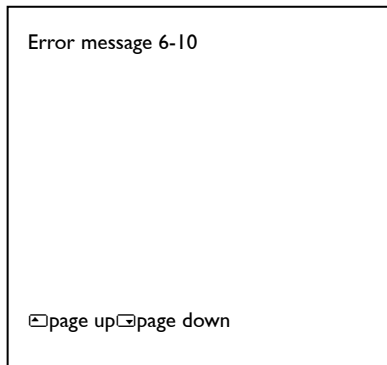

Press Page down

S8

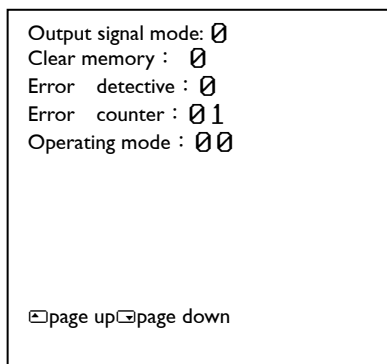

Press correct password on S1 display screen will go to S8 setting screen.
 Password is 7890.

Frequent Error message history records from Items 6 to 10.

1. Output signal mode:

Setting up to 0 for PLC mode 0 and PLC mode 2 control: setting up to 1 for TIMER mode 1.

2. Clear Memory:

Press 1 to allow system initialization (Note: all parameter and information will become manufacturer setting) , Press 0 system will not initialize.

3. Error detective:

Press 1 system will monitor motor idling error; Press 0 system will not detect motor idling error.

4. Error counter:

Press 1 to activate function "motor error detection times". When Motor error reached setting "error detection times", System will display error information.

5. Operating mode:

Press 00 for Standard setting. For Customized demand settings.



4.6 Instruction of System Mode

4.6.1 Instruction of TIMER Mode I

After selecting TIMER Mode I, use Hand-Set to set greasing frequency interval and timing. Below are operating examples of each model.

4.6.1.1 Model LUG-411

```

Mode Selection : 1
0:PLC 1:TIMER 2::PLC
PI cycle : 000 days
           04 hours 00 minutes
PI motion : 02 times
P2 cycle : 000 days
           00 hours 00 minutes
P2 motion : 01 times

page up page down

```



Press Page down

```

Power voltage: 24.0
PI cycle and timer :
cycle: 000000
Timer: 0000240
P2 cycle and timer :
cycle: 000000
Timer: 0000000

```

page up page down



Press Page down

```

Power voltage: 24.0
PI cycle and timer :
cycle: 000000
Timer: 0000232
P2 cycle and timer :
cycle: 000000
Timer: 0000000

```

page up page down

Select 1 Timer Mode, then set PI cycle time 4hours and PI motion 2 times. This means after 4 hours PI will push 2 strokes at 1.1 outlet total dispenses 0.3cm³

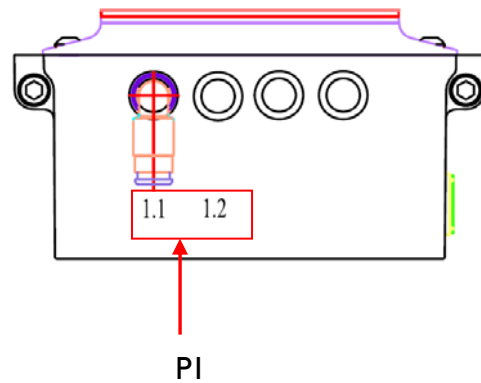

Time elapsed 8 minutes



```

Power voltage: 24.0
PI cycle and timer :
cycle: 000000
Timer: 0000240
P2 cycle and timer :
cycle: 000000
Timer: 0000000

I.1 operating
page up page down

```

Timer countdown finishes, system restarts countdown again.

Pump I begins dispensing grease 0.15 cm³ at Outlet I.1.



```

Power voltage: 24.0
PI cycle and timer :
cycle: 000001
Timer: 0000240
P2 cycle and timer :
cycle: 000000
Timer: 0000000

I.2 operating
page up page down

```

PI cycle records 1 cycle as total no. of stroke.

Outlet I.2 is completely sealed; therefore outlet I.1 will dispense again 0.15cm³ grease.



```

Power voltage: 24.0
PI cycle and timer :
cycle: 000002
Timer: 0000240
P2 cycle and timer :
cycle: 000000
Timer: 0000000

page up page down

```

PI cycle records 2 cycles as total no. of stroke in outlet I.1 with total grease 0.3cm³.



4.6.1.2 Model LUG-412

```

Mode Selection : 1
0:PLC 1:TIMER 2::PLC
PI cycle : 000 days
04 hours 00 minutes
PI motion : 02 times
P2 cycle : 000 days
00 hours 00 minutes
P2 motion : 01 times

page up page down

```



Press Page down

```

Power voltage: 24.0
PI cycle and timer :
cycle: 000000
Timer: 0000240
P2 cycle and timer :
cycle: 000000
Timer: 0000000

```

page up page down



```

Power voltage: 24.0
PI cycle and timer :
cycle: 000000
Timer: 0000232
P2 cycle and timer :
cycle: 000000
Timer: 0000000

```

page up page down



Select I Timer Mode, then set PI cycle time 4 hours and PI motion 2 times. This means after 4 hours PI will deliver 1 stroke at outlet 1.1 and then outlet 1.2 with each 0.15 cm³ of grease.

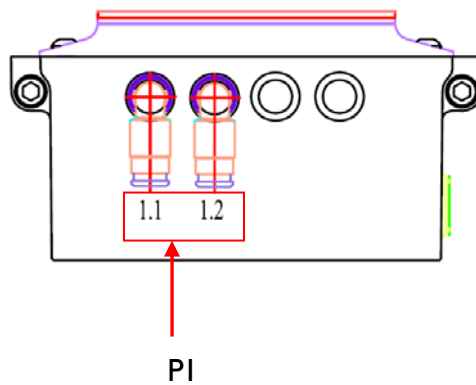

Time elapsed 8 minutes



```

Power voltage: 24.0
PI cycle and timer :
cycle: 000000
Timer: 0000240
P2 cycle and timer :
cycle: 000000
Timer: 0000000

I.1 operating

page up page down

```

Timer countdown finishes, system restarts countdown again.

Pump 1 begins dispensing grease 0.15 cm³ at Outlet I.1.



```

Power voltage: 24.0
PI cycle and timer :
cycle: 000001
Timer: 0000240
P2 cycle and timer :
cycle: 0000000
Timer: 0000000

I.2 operating

page up page down

```

PI cycle records 1 cycle as total no. of stroke

Pump 1 begins dispensing grease 0.15 cm³ at Outlet I.2.



```

Power voltage: 24.0
PI cycle and timer :
cycle: 000002
Timer: 0000240
P2 cycle and timer :
cycle: 0000000
Timer: 0000000

page up page down

```

PI cycle records 2 cycles as total no. of stroke with each outlet I.1 & I.2 dispensing 0.15 cm³ total grease 0.3cm³



4.6.1.3 Model LUG-422

Set PI Outlet 1.1 to perform greasing.

```

Mode Selection : 1
0:PLC 1:TIMER 2::PLC
PI cycle : 000 days
04 hours 00 minutes
PI motion : 02 times
P2 cycle : 000 days
00 hours 00 minutes
P2 motion : 01 times

page up page down

```

Select I Timer Mode, then set PI cycle time 4hours and PI motion 2 times. This means after 4 hours PI will push 2 strokes at outlet 1.1 total grease dispenses 0.3cm³



Press Page down

```

Power voltage: 24.0
PI cycle and timer :
cycle: 000000
Timer: 0000240
P2 cycle and timer :
cycle: 000000
Timer: 0000000

```

page up page down

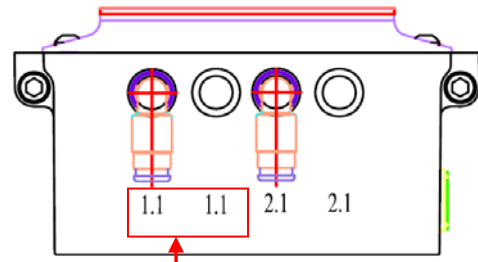

P1



```

Power voltage: 24.0
PI cycle and timer :
cycle: 000000
Timer: 0000232
P2 cycle and timer :
cycle: 000000
Timer: 0000000

```

page up page down

Time elapsed 8 minutes





```

Power voltage: 24.0
PI cycle and timer :
cycle: 000000
Timer: 0000240
P2 cycle and timer :
cycle: 000000
Timer: 0000000

I.1 operating

page up page down

```

Timer countdown finishes, system restarts countdown again.

Pump I begins dispensing grease 0.15 cm³at Outlet I.1.



```

Power voltage: 24.0
PI cycle and timer :
cycle: 000001
Timer: 0000240
P2 cycle and timer :
cycle: 000000
Timer: 0000000

I.2 operating

page up page down

```

PI cycle records 1 cycle as total no. of stroke.

Outlet I.2 is completely sealed; therefore outlet I.1 will dispense again 0.15cm³ grease.



```

Power voltage: 24.0
PI cycle and timer :
cycle: 000002
Timer: 0000240
P2 cycle and timer :
cycle: 000000
Timer: 0000000

page up page down

```

PI cycle records 2 cycles as total no. of stroke in outlet I.1 with total grease 0.3cm³.



Set P2 Outlet 2.1 to perform greasing.

```

Mode Selection : 1
0:PLC 1:TIMER 2::PLC
P1 cycle : 000 days
00 hours 00 minutes
P1 motion : 01 times
P2 cycle : 000 days
04 hours 00 minutes
P2 motion : 02 times

page up page down

```



Press Page down

```

Power voltage: 24.0
P1 cycle and timer :
cycle: 000000
Timer: 00000000
P2 cycle and timer :
cycle: 000000
Timer: 0000240

```

page up page down



Press Page down

```

Power voltage: 24.0
P1 cycle and timer :
cycle: 000000
Timer: 00000000
P2 cycle and timer :
cycle: 000000
Timer: 0000232

```

page up page down



Select 1 Timer Mode, then set P2 cycle time 4hours and P2 motion 2 times. This means after 4 hours P2 will push 2 strokes at 2.1 outlet total grease dispenses 0.3cm³

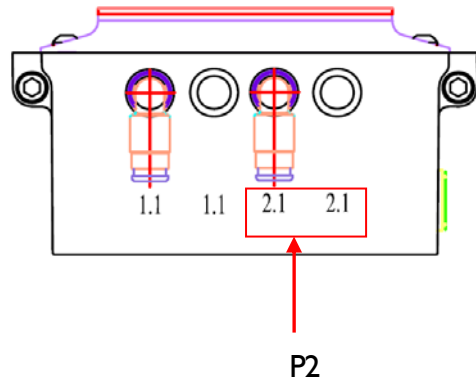

Time elapsed 8 minutes



```

Power voltage: 24.0
PI cycle and timer :
cycle: 000000
Timer: 0000000
P2 cycle and timer :
cycle: 000000
Timer: 0000240
2.1 operating
page up page down

```

Timer countdown finishes, system restarts countdown again.

Pump 2 begins dispensing grease 0.15 cm³ at Outlet 2.1.



```

Power voltage: 24.0
PI cycle and timer :
cycle: 000000
Timer: 0000000
P2 cycle and timer :
cycle: 000001
Timer: 0000240
2.2 operating
page up page down

```

P2 cycle records 1 cycle as total no. of stroke

Outlet 2.2 is completely sealed; therefore outlet 2.1 will dispense again 0.15cm³ grease.



```

Power voltage: 24.0
PI cycle and timer :
cycle: 000000
Timer: 0000000
P2 cycle and timer :
cycle: 000002
Timer: 0000240
page up page down

```

P2 cycle records 2 cycles as total no. of stroke in outlet 2.1 with total grease 0.3cm³.



4.6.1.4 Model LUG-423

Set PI Outlet 1.1 to perform greasing.

```

Mode Selection : 1
0 :PLC  1 :TIMER  2::PLC
PI cycle : 000 days
          04 hours 00 minutes
PI motion : 02 times
P2 cycle : 000 days
          00 hours 00 minutes
P2 motion : 01 times
page up page down

```

Select I Timer Mode, then set PI cycle time 4hours and PI motion 2 times. This means after 4 hours PI will push 2 strokes at outlet 1.1 total dispenses 0.3cm³

Press Page down

```

Power voltage: 24.0
PI cycle and timer :
cycle: 000000
Timer: 0000240
P2 cycle and timer :
cycle: 000000
Timer: 0000000
page up page down

```

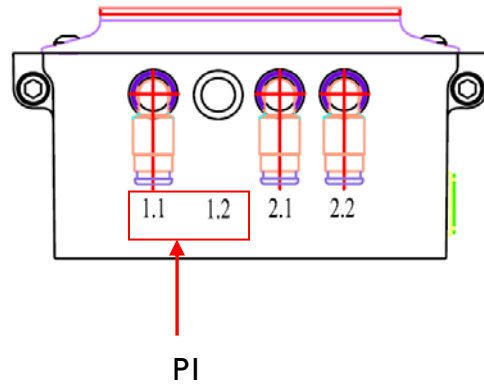

Press Page down

```

Power voltage: 24.0
PI cycle and timer :
cycle: 000000
Timer: 0000232
P2 cycle and timer :
cycle: 000000
Timer: 0000000
page up page down

```

Time elapsed 8 minutes

Press Page down



```

Power voltage: 24.0
PI cycle and timer :
cycle: 000000
Timer: 0000240
P2 cycle and timer :
cycle: 000000
Timer: 0000000
I.1 operating
page up page down

```

Timer countdown finishes, system restarts

Pump I begins dispensing grease 0.15 cm³ at Outlet I.1.



```

Power voltage: 24.0
PI cycle and timer :
cycle: 000001
Timer: 0000240
P2 cycle and timer :
cycle: 0000000
Timer: 0000000
I.2 operating
page up page down

```

PI cycle records 1 cycle as total no. of stroke

Outlet I.2 is completely sealed; therefore outlet I.1 will dispense again 0.15cm³ grease.



```

Power voltage: 24.0
PI cycle and timer :
cycle: 000002
Timer: 0000240
P2 cycle and timer :
cycle: 0000000
Timer: 0000000
page up page down

```

PI cycle records 2 cycles as total no. of stroke in outlet I.1 with total grease 0.3cm³.



Set P2 Outlet 2.1 & 2.2 to perform greasing.

```

Mode Selection : 1
0:PLC  1:TIMER  2::PLC
P1 cycle : 000 days
          00 hours 00 minutes
P1 motion : 01 times
P2 cycle : 000 days
          04 hours 00 minutes
P2 motion : 02 times

page up page down

```



Press Page down

```

Power voltage: 24.0
P1 cycle and timer :
cycle: 000000
Timer: 00000000
P2 cycle and timer :
cycle: 000000
Timer: 0000240

```

page up page down



```

Power voltage: 24.0
P1 cycle and timer :
cycle: 000000
Timer: 00000000
P2 cycle and timer :
cycle: 000000
Timer: 0000232

```

page up page down



Select 1 Timer Mode, then set P2 cycle time 4hours and P2 motion 2 times. This means after 4 hours P2 will deliver 1st stroke at outlet 2.1 and then outlet 2.2 with 2nd stroke 0.15 cm³

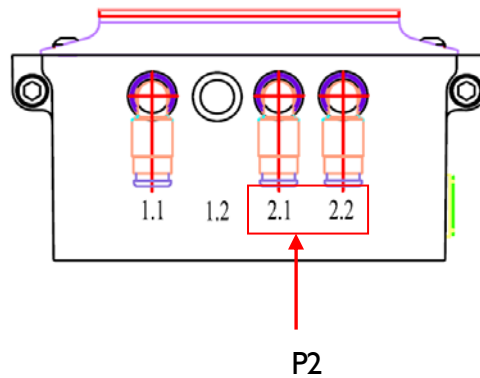

Time elapsed 8 minutes



```

Power voltage: 24.0
P1 cycle and timer :
cycle: 000000
Timer: 0000000
P2 cycle and timer :
cycle: 000000
Timer: 0000240
2.1 operating
page up page down

```

Timer countdown finishes, system restarts countdown again.

Pump 2 begins dispensing grease 0.15 cm³ at Outlet 2.1.



```

Power voltage: 24.0
P1 cycle and timer :
cycle: 000000
Timer: 0000000
P2 cycle and timer :
cycle: 000001
Timer: 0000240
2.2 operating
page up page down

```

P2 cycle records 1 cycle as total no. of stroke

Pump 2 begins dispensing grease 0.15 cm³ at Outlet 2.1.



```

Power voltage: 24.0
P1 cycle and timer :
cycle: 000000
Timer: 0000000
P2 cycle and timer :
cycle: 000002
Timer: 0000240
page up page down

```

P2 cycle records 2 cycles as total no. of stroke with each outlet 2.1 & 2.2 dispensing 0.15 cm³ total grease 0.3cm³



4.6.1.5 Model LUG-424

Set PI Outlet 1.1 & 1.2 to perform greasing.

```

Mode Selection : 1
0:PLC 1:TIMER 2::PLC
PI cycle : 000 days
04 hours 00 minutes
PI motion : 02 times
P2 cycle : 000 days
00 hours 00 minutes
P2 motion : 01 times

page up page down

```

Select I Timer Mode, then set PI cycle time 4hours and PI motion 2 times. This means after 4 hours PI will deliver 1st stroke at outlet 1.1 and then outlet 1.2 with 2nd stroke 0.15 cm³

Press Page down

```

Power voltage: 24.0
PI cycle and timer :
cycle: 000000
Timer: 0000240
P2 cycle and timer :
cycle: 000000
Timer: 0000000

```

page up page down

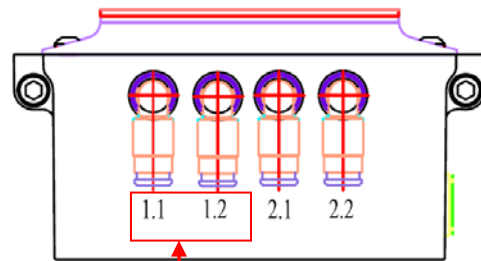

PI

Press Page down

```

Power voltage: 24.0
PI cycle and timer :
cycle: 000000
Timer: 0000232
P2 cycle and timer :
cycle: 000000
Timer: 0000000

```

page up page down

Time has elapsed 8 minutes

Press Page down



```

Power voltage: 24.0
PI cycle and timer :
cycle: 000000
Timer: 0000240
P2 cycle and timer :
cycle: 000000
Timer: 0000000
I.1 operating
page up page down

```

Timer countdown finishes, system restarts countdown again.

Pump I begins dispensing grease 0.15 cm³ at Outlet I.1.



```

Power voltage: 24.0
PI cycle and timer :
cycle: 000001
Timer: 0000240
P2 cycle and timer :
cycle: 000000
Timer: 0000000
I.2 operating
page up page down

```

PI cycle records 1 cycle as total no. of stroke

Pump I begins dispensing grease 0.15 cm³ at Outlet I.2.



```

Power voltage: 24.0
PI cycle and timer :
cycle: 000002
Timer: 0000240
P2 cycle and timer :
cycle: 000000
Timer: 0000000
page up page down

```

PI cycle records 2 cycles as total no. of stroke with each outlet I.1 & I.2 dispensing 0.15 cm³ total grease 0.3cm³



Set P2 Outlet 2.1 & 2.2 to perform greasing.

```

Mode Selection : 1
0:PLC 1:TIMER 2:PLC
P1 cycle : 000 days
00 hours 00 minutes
P1 motion : 01 times
P2 cycle : 000 days
04 hours 00 minutes
P2 motion : 02 times

page up page down

```



Press Page down

```

Power voltage: 24.0
P1 cycle and timer :
cycle: 000000
Timer: 00000000
P2 cycle and timer :
cycle: 000000
Timer: 0000240

```

page up page down



```

Power voltage: 24.0
P1 cycle and timer :
cycle: 000000
Timer: 00000000
P2 cycle and timer :
cycle: 000000
Timer: 0000232

```

page up page down



Select 1 Timer Mode, then set P2 cycle time 4hours and P2 motion 2 times. This means after 4 hours P2 will deliver 1st stroke at outlet 2.1 and then outlet 2.2 with 2nd stroke 0.15 cm³

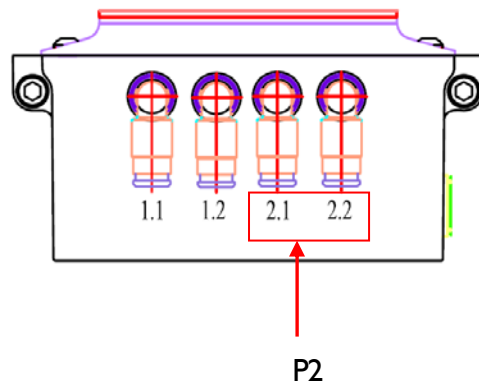

Time elapsed 8 minutes



Power voltage: 24.0
 P1 cycle and timer :
 cycle: 000000
 Timer: 0000000
 P2 cycle and timer :
 cycle: 000000
 Timer: 0000240
 2.1 operating
 page up page down

Timer countdown finishes, system restarts countdown again.

Pump 2 begins dispensing grease 0.15 cm³ at Outlet 2.1.



Power voltage: 24.0
 P1 cycle and timer :
 cycle: 000000
 Timer: 0000000
 P2 cycle and timer :
 cycle: 000001
 Timer: 0000240
 2.2 operating
 page up page down

P2 cycle records 1 cycle as total no. of stroke

Pump 2 begins dispensing grease 0.15 cm³ at Outlet 2.2.



Power voltage: 24.0
 P1 cycle and timer :
 cycle: 000000
 Timer: 0000000
 P2 cycle and timer :
 cycle: 000002
 Timer: 0000240
 page up page down

P2 cycle records 2 cycles as total no. of stroke per outlet 2.1 & 2.2 dispensing 0.15 cm³ total grease 0.3cm³



4.6.2 Instruction of PLC Mode 2

The main purpose of PLC mode 2 control is to set up and input the duration time of the 24V signal which from PIN2 pin of lubricator power connector, and then can be control each oil outlet for oil dispense, and following the changed by output signal, notify PLC machine current situation of the lubricator, request to set up mode 2 if you need to use it, the following is the PLC mode 2 control schematic.

4.6.2.1 Model LUG-411 、LUG-412

PLC control diagram:

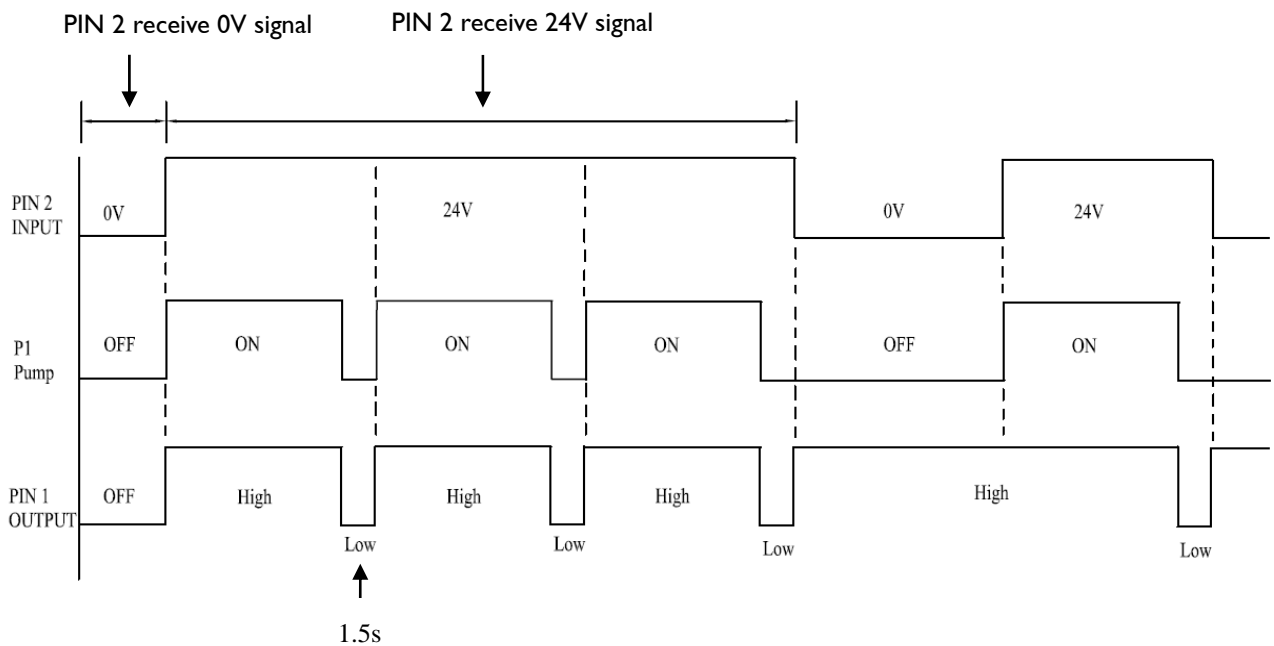

- (1) Lubricator power ON, pump P1 outlet to dispense oil continuously when the PIN 2 receiving 24V signal. One stroke per outlet will dispense oil 0.15cm^3 .
- (2) When the pump P1 complete the dispensing 1 time, PIN 1 output signal changed from HIGH to LOW, the signal duration is 1.5s. This function is applied to inform PLC that the Lubricator has been dispensed 1 time.
- (3) When PIN 2 receiving the signal from 24V to 0V, pump 1 will stop dispensing. Meanwhile, PIN 1 output HIGH signal continuously.

It is known from the PLC mode 2 control diagram that the P1 oil outlet has the same oil dispensing time. Therefore, it is only requested to set the duration of the signal input to the PIN2 pin 24V to control the oil discharge times of the P1 oil outlet. The time taken for each dispensing of the outlet is 1.5s.



The signal waveform on PIN1 when oil exhausting:

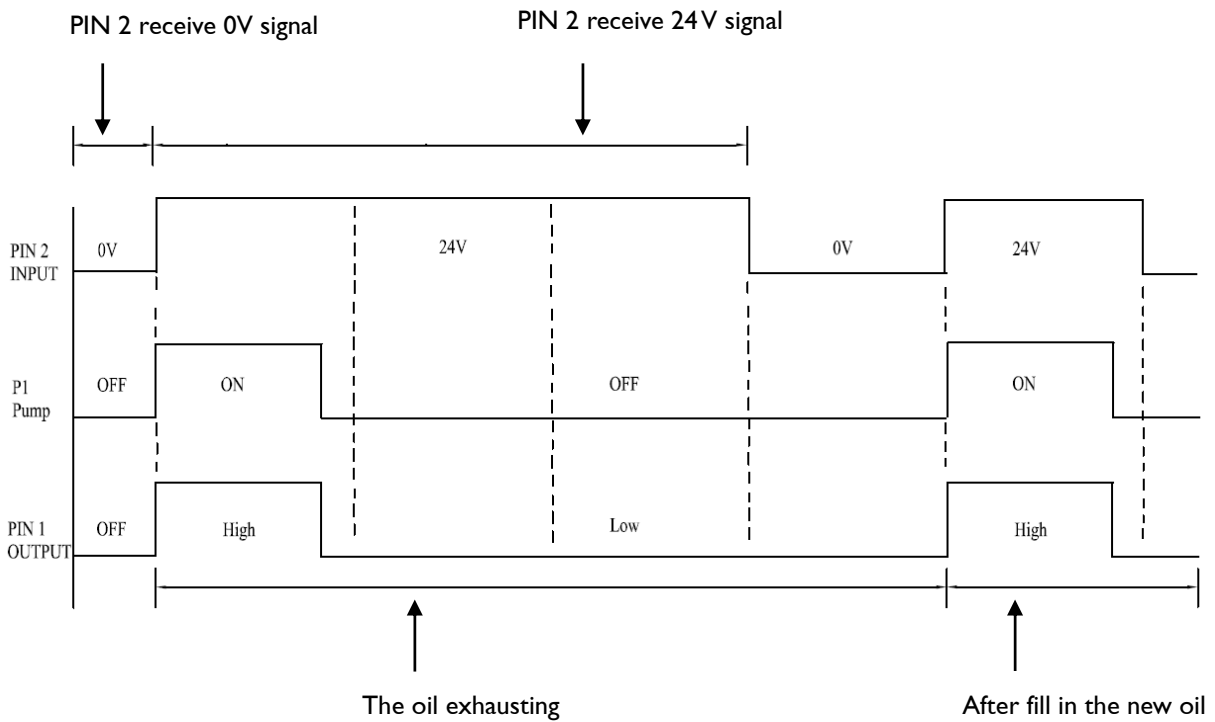

- (1) When lubricator detect the exhausting oil, waiting and after PI for dispensed I cycle time, then PIN I will output the signal from HIGH to LOW which inform the user to replenish the oil. During this duration, the pump I can not be dispensed.
- (2) After replenish the oil into lubricator, PIN I will output the signal from LOW to HIGH, the pump I can restart to dispense the oil.



The signal waveform on PIN 1 when lubricator can not dispense (The tube is block)

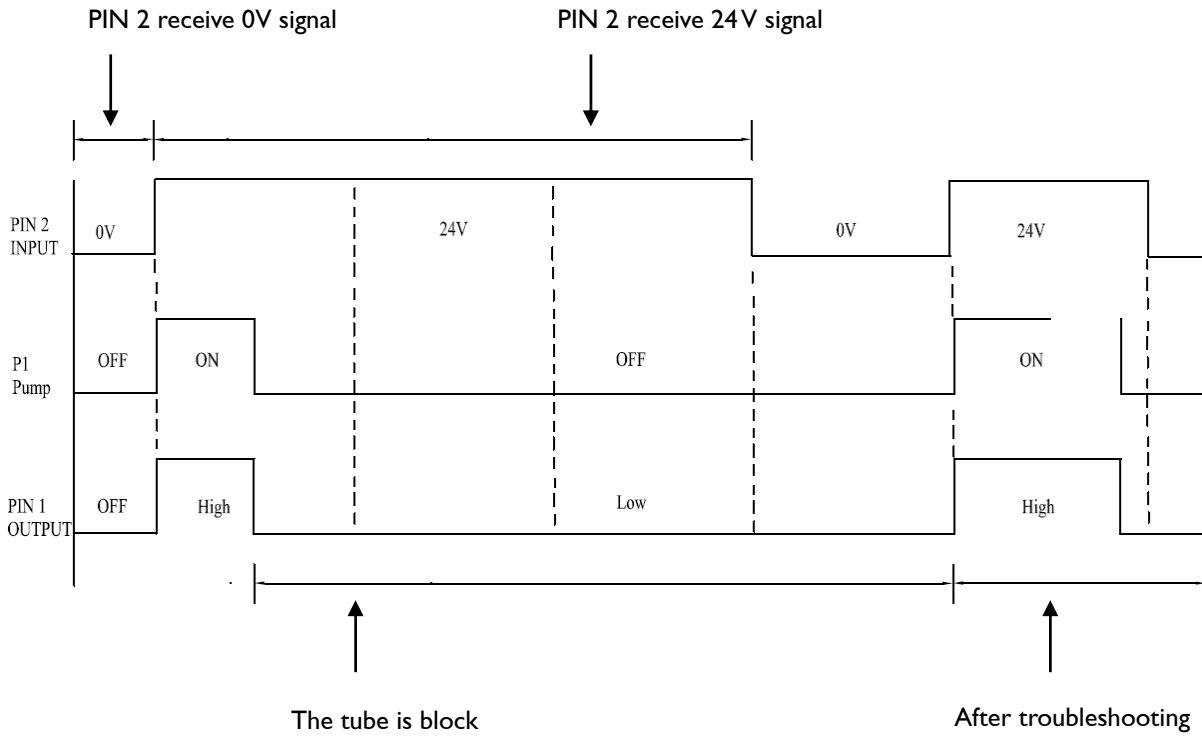

- (1) When lubricator detect the malfunction (ex: the tube is block), PIN 1 will change the signal from HIGH to LOW, and stop dispense the oil.
- (2) After troubleshooting, PIN 1 will change the signal from LOW to HIGH and restart to dispense the oil. The troubleshooting instruction please refer to page 51.



4.6.2.2 Model LUG-422、LUG-423、LUG-424

PLC control diagram:

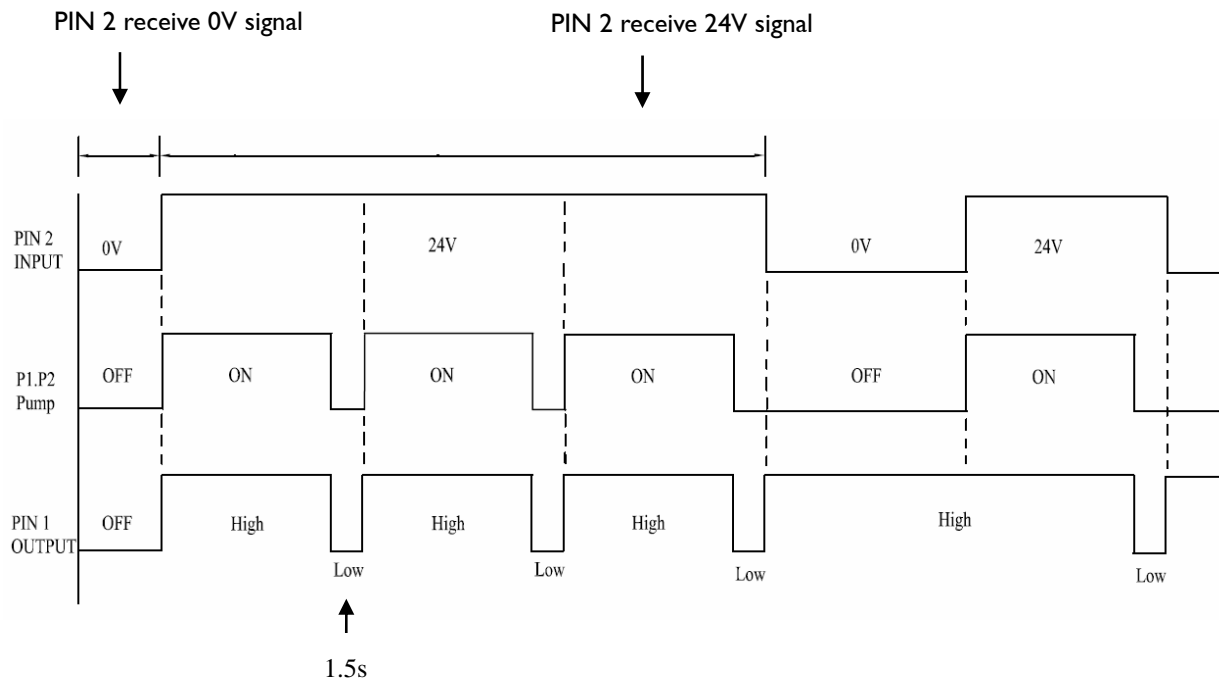

- (1) Lubricator power ON, pump P1 and P2 outlet to dispense oil continuously when the PIN 2 receiving 24V signal. One stroke per outlet will dispense oil 0.15cm^3
- (2) When the pump P1 and P2 complete the dispensing 1 time, PIN 1 output signal changed from HIGH to LOW, the signal duration is 1.5s. This function is applied to inform PLC that the Lubricator has been dispensed 1 time.
- (3) When PIN 2 receiving the signal from 24V to 0V, pump P1 and P2 will stop dispensing. Meanwhile, PIN 1 output signal HIGH continuously.

The duration is the same of one stroke per outlet according to the PLC model 2 control diagram. Hence, we can control the stroke times per outlet for pump P1 and P2 by the duration of 24V signal on PIN 2. The duration of both Pump P1 and P2 are 1s for one stroke individually.



The signal waveform on PIN1 when oil exhausting:

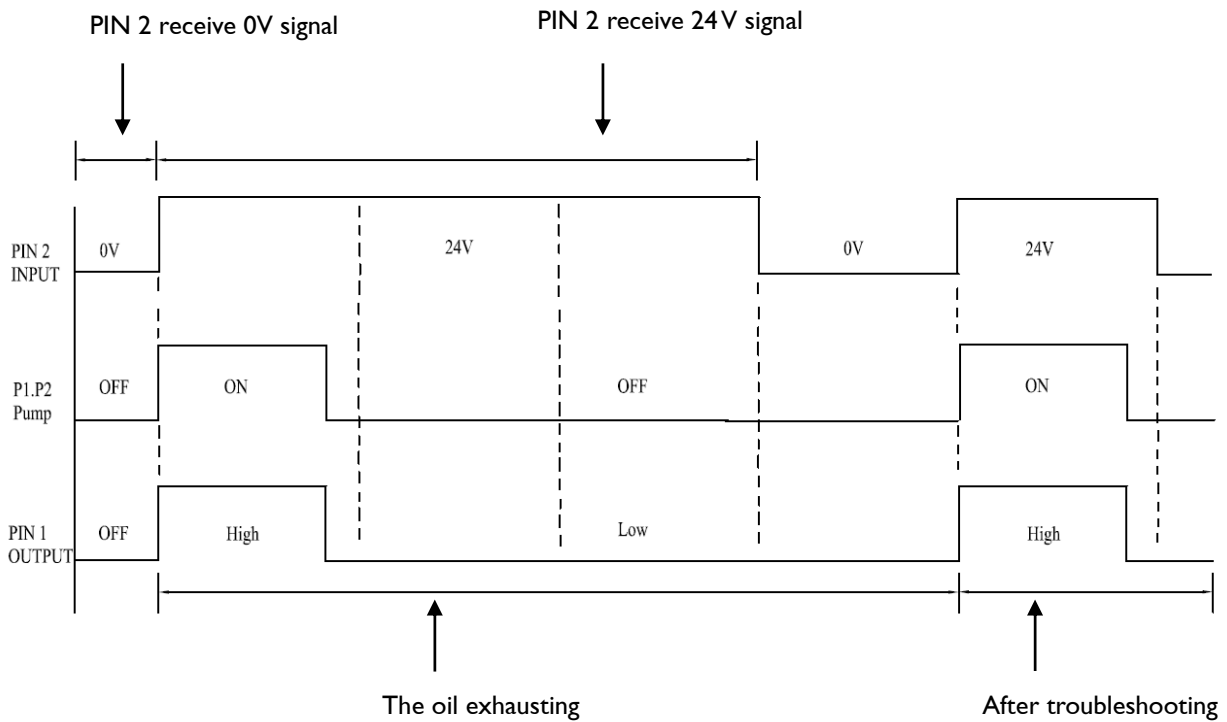

- (1) When lubricator detect the exhausting oil, waiting and after both of P1 and P2 for dispensed I time, PIN 1 will output the signal from HIGH to LOW which inform the user to replenish the oil. During this duration, the pump P1 and P2 can not be dispensed.
- (2) After replenish the oil into lubricator, PIN 1 will output the signal from LOW to HIGH. Meanwhile, the pump P1 and P2 can restart to dispense the oil.



The signal waveform on PIN 1 when lubricator can not dispense (The tube is block)

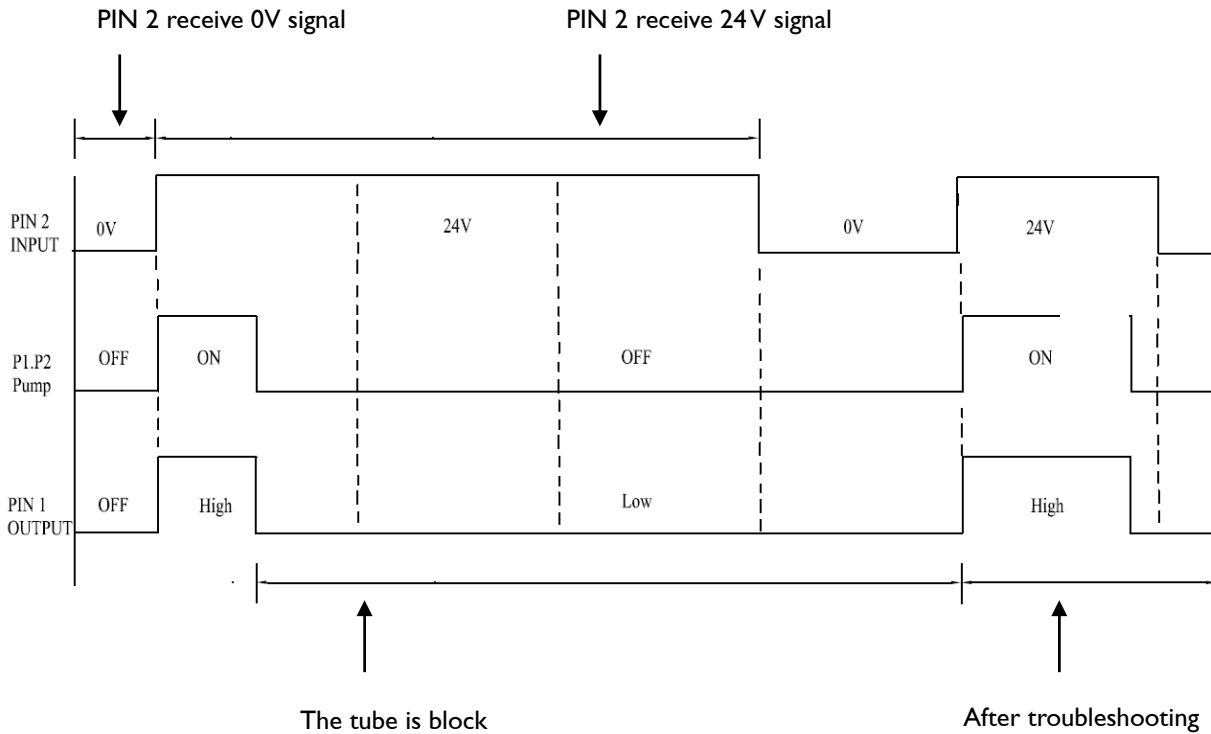

(1) When lubricator detect the malfunction (ex: the tube is block), pump P1 and P2 stop dispense the oil immediately. Meanwhile, PIN 1 will change the signal from HIGH to LOW for inform the malfunction message to user.

(2) After troubleshooting, PIN 1 will change the signal from LOW to HIGH. Meanwhile, pump P1 and P2 restart to dispense the oil. The troubleshooting instruction please refer to page 51.



4.6.3 Clear Motor Timer Setting

(I) Clear Motor Timer

Set I to clear existing motor parameters, the system recorded output P1 and P2 cycles are all erased 0. This function allows users to know lubricator total cycles.

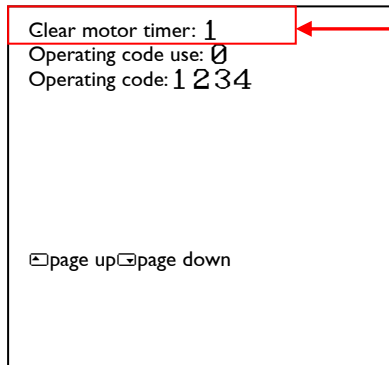

Key "Clear motor timer" as I.

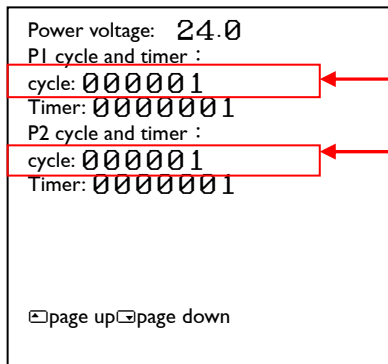
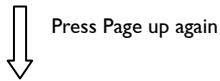

Previous records of total no. of strokes / cycles for Pump 1 & 2.

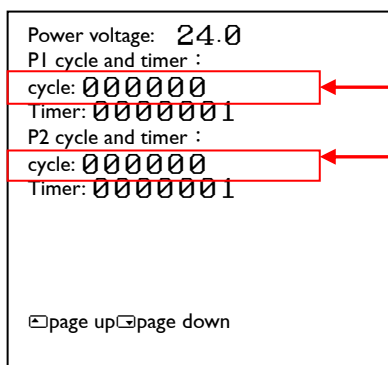

P1 & P2 records total no. of strokes / cycles will be erased.



(2) Password Setting

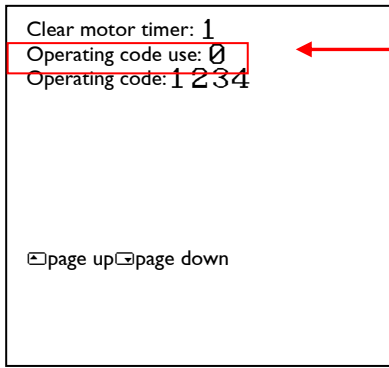

Set 0 "Operating code use" (No need to enter password), Press "SET" in S1 display and enter S2 screen.

SI ↓ Press Reset



Press Set →

S2

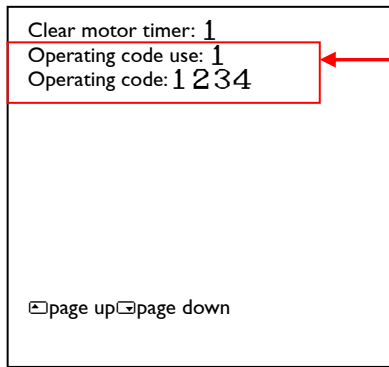
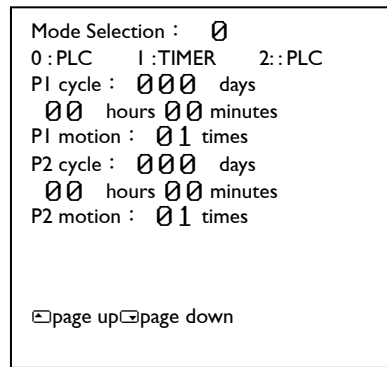

Set "Operating code use" as 1 and Set "Operating Code" as 1234, at this moment S1 screen require password. Enter "1234" to go S2 screen.

SI ↓ Press Reset



Key password 1234, and press Set →

S2

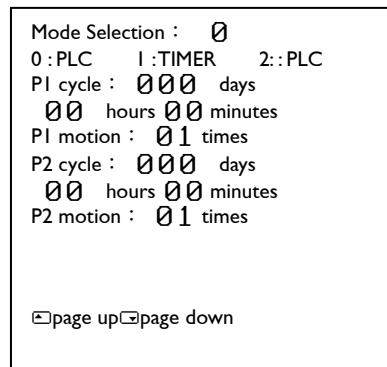



4.6.4 Description of Error Message

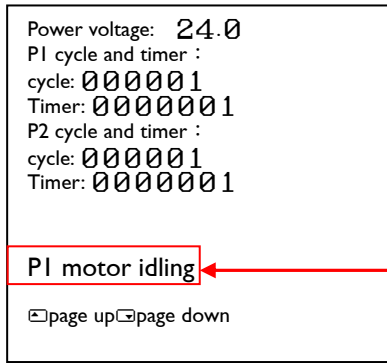

Error message appears on screen for example PI motor idling.

S6

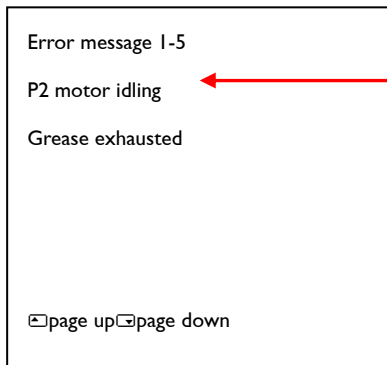

“PI Motor idling” display in system “Error Message Record” , new message is displayed in S6 screen and total 5 error messages and then 6th message will be saved in S7screen.

S7

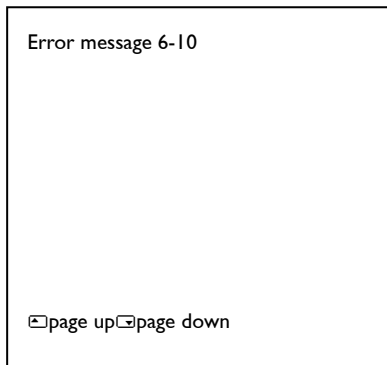



Error message description:

Error message	Description	Remedy
PI Motor Idle	Lubricator internal P1 motor idling.	Please refer Page 51
P2 Motor Idle	Lubricator internal P2 motor idling.	Please refer Page 51
P1 motor or pipe block	Lubricator internal P2 motor cannot rotate.	Please refer Page 51
P2 motor or pipe block	Lubricator internal P2 motor cannot rotate.	Please refer Page 51
Grease exhausted	Grease cartridge is empty.	Please refer Page 51
Memory reading error, Memory writing error	Input voltage 1.24V not reached standard 2.Lubricator PCB board malfunction	1.Check Input Voltage 24V 2.Contact Manufacturer technician

4.6.5 Description of Output Signal Mode

After installing Lubricator Hand-Set, the lubricator output signal can be changed. The Lubricator can be used in PLC control Mode 0 or Timer Mode 1 or PLC Mode 2. Instructions are as follows:

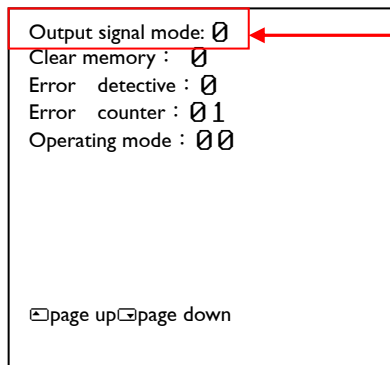

Set "Output Signal Mode" 0 for PLC control Mode 0 and PLC control Mode 2. Refer to Chapter 3.5 for PLC control Mode 0 illustration. And refer 4.6.2 chapter for PLC Mode 2.

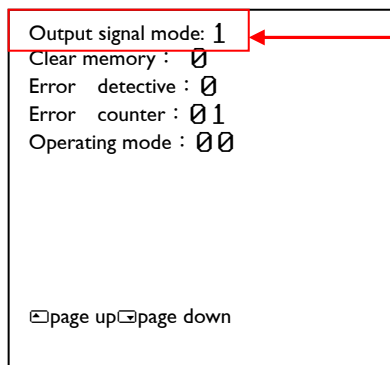

Output Signal Mode, Set 1 as "Timer Mode 1 control" .



Set "Output Signal Mode" as I, control mode as TIMER mode I, power plug PIN I output waveform is display below. This function is used to install additional alarm device to inform the user that the lubricator is malfunction and require troubleshooting.

Lubricator Power OFF

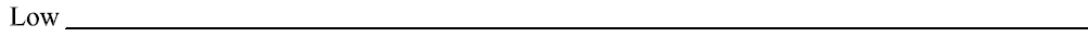

Lubricator Power ON no occurrence of malfunction



Lubricator power OFF and power ON no occurrence of malfunction, PIN I output signal as LOW.

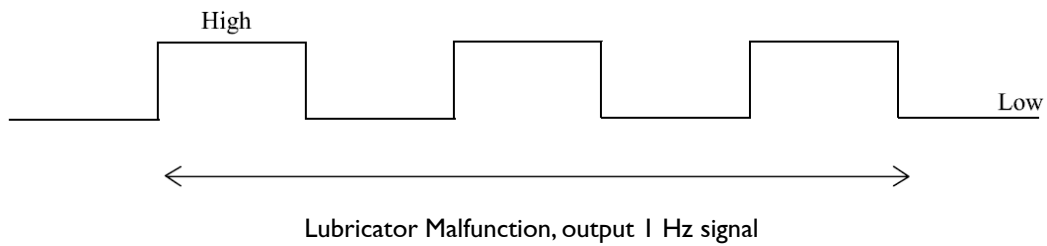

If the Lubricator malfunction, PIN I will continue to output 1Hz signal, at this moment please refer to below table below for Lubricator troubleshooting .

Malfunction	Reason	Remedy
Lubricator cannot dispense grease	PA Tube contain trapped air	Refer to chapter 3.8 for troubleshooting.
	Lubricator internal motor blockage, PA Tube Blockage	Check PA Tube for blockage like foreign particles or Outlet PA Tube length is too long.
	Lubricator internal motor idling	Contact Manufacturer
	Black Sensor plate reaches low grease level detection zone means grease exhausted	Refer APPENDIX B for replacement of new grease Cartridge.



4.6.6 TIMER Mode I Control Output Wiring Instruction

Wiring of Lubricator with alarm device.

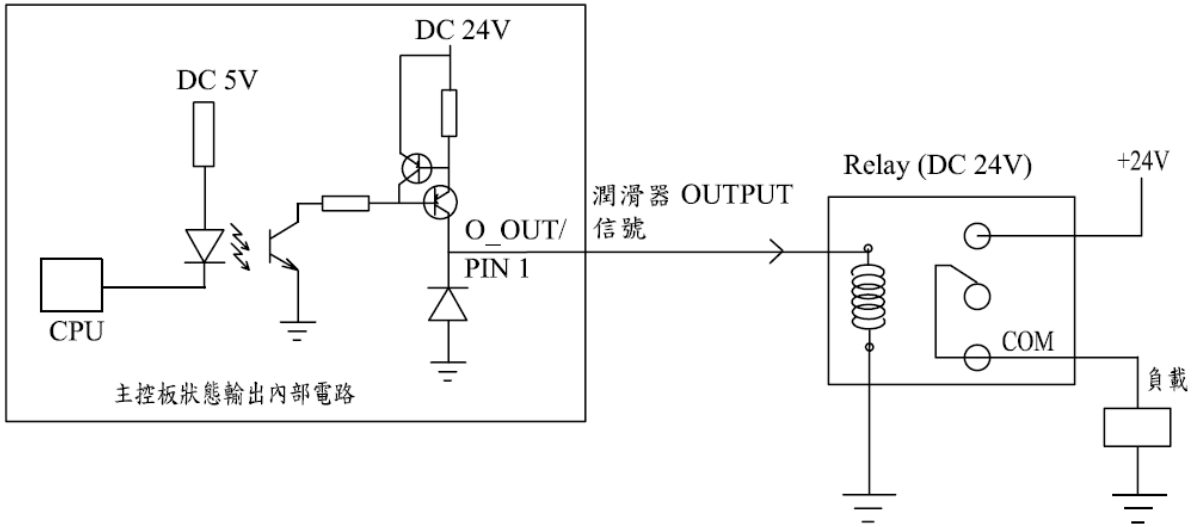

Lubricator Output Electrical Specification

Rated Voltage : DC 24V
Maximum Output Current : 100mA



4.6.7 Clear Memory Illustration

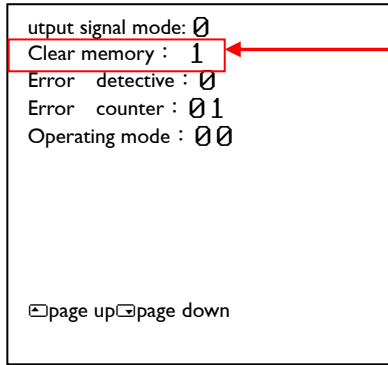

Set "Clear Memory" as 1, system will initialize lubricator parameters returning to its original manufacturer setting as shown below.

Set "Clear Memory" as 1, Hand-Set all parameters return to original manufacturer setting.

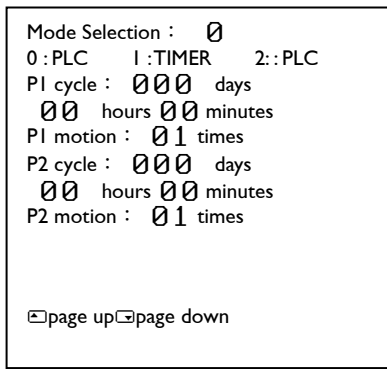

Manufacturer Setting

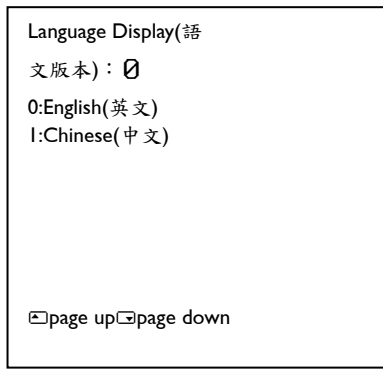

Manufacturer Setting

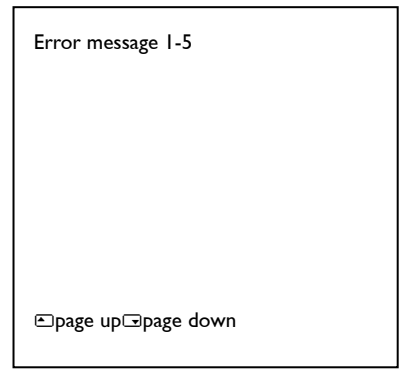

Manufacturer Setting

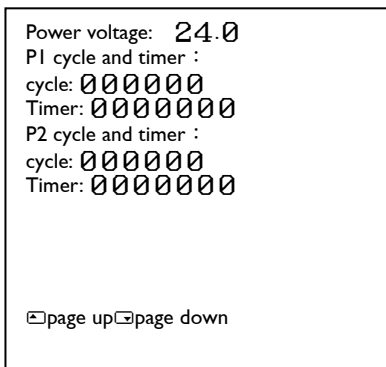

Manufacturer Setting

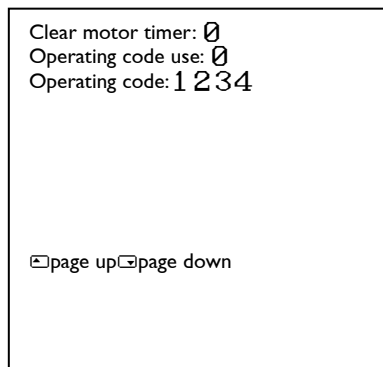

Manufacturer Setting

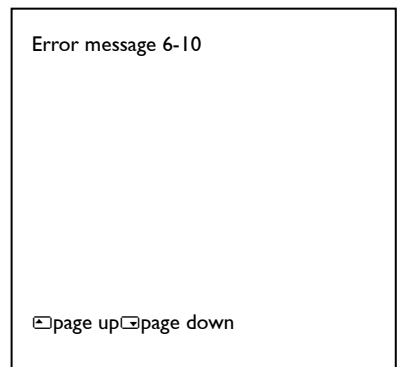

Manufacturer Setting



4.6.8 Motor Error Detective and Error Counter

When Lubricator is unable to dispense grease this may due to internal motor gear maybe loosened making motor idling thus causing lubricator to fail to deliver grease. This function can be used to check.

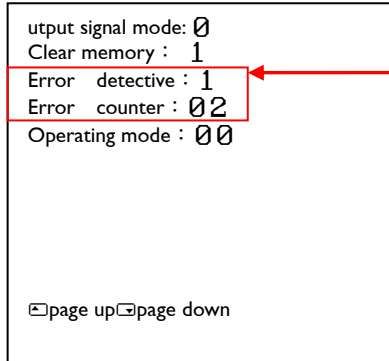

Set "Error Detective" 1, Motor error appears, system will monitor and display on Hand-Set screen. This feature needs to be used together with motor "Error counter".

Set motor "error detection" as 2, take PI motor occurrence error as an example.

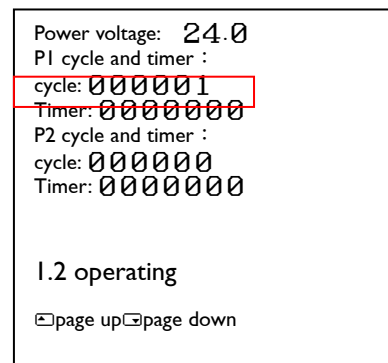
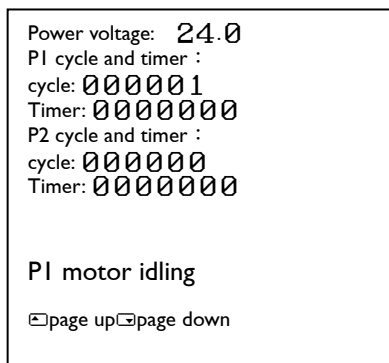
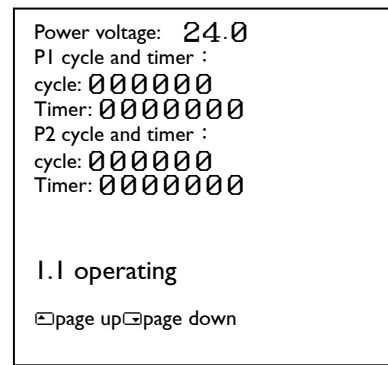
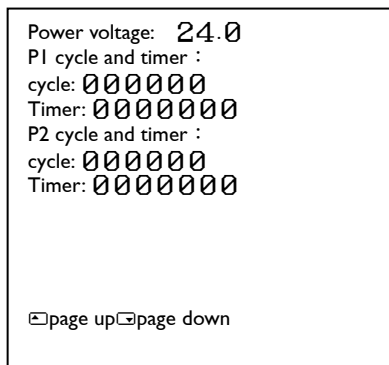

System detected PI motor idling and no. of motor errors reached 2. Lubricator stopped dispensing grease and system displayed an error message.

System detected PI motor idling, but no. of motor errors did not reached 2. Lubricator continues dispensing grease and system will not display an error message.



4.7 Lubricator Installation Procedure (TIMER mode I Control)

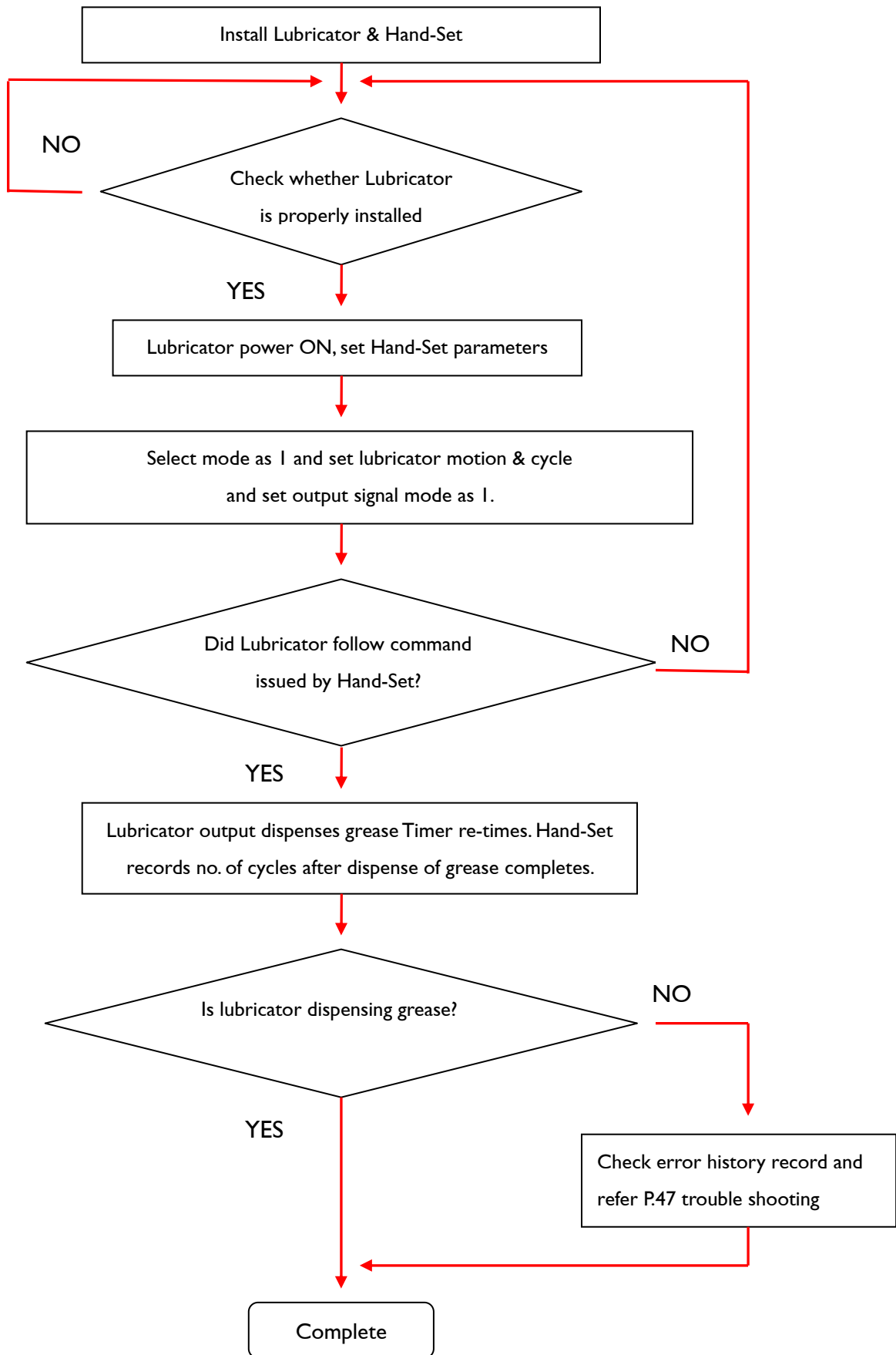



4.8 Lubricator Installation Procedure (PLC mode 2 Control)

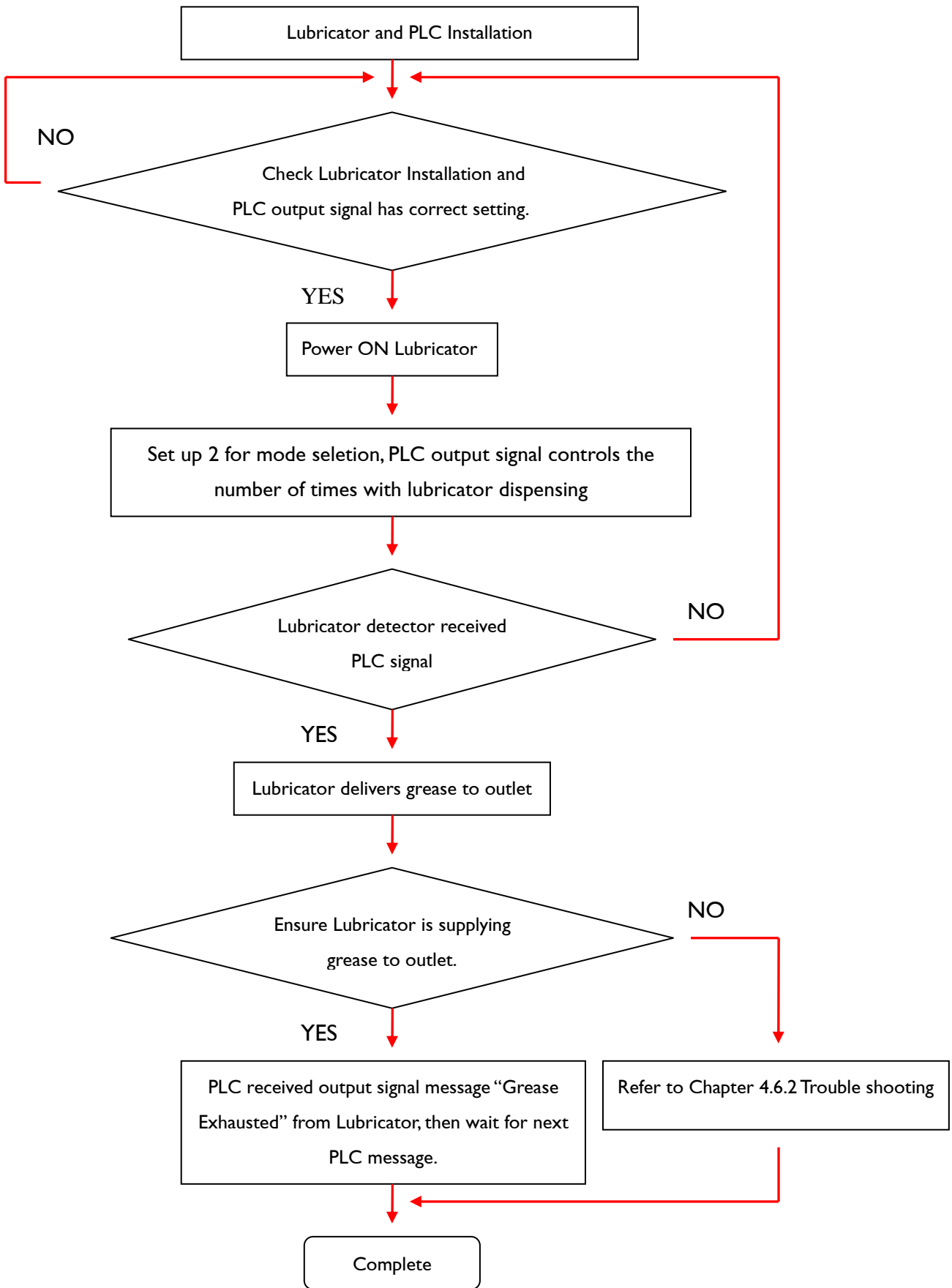



4.9 Instruction of Continuous Grease Dispensing.

After installing Lubricator PA tubes, user may press “PI ON” key function to allow lubricator to continuously dispense grease until empty PA tube is completely filled with grease and then press “PI OFF” key to stop dispensing grease. Lubricator with an excess gas inside PA tubes, user may press “PI ON” key for continuous grease dispensing so as to discharge excess gas trapped inside tube.

Description of Set-Up Example

(I) Press PI on for continuous grease dispensing.

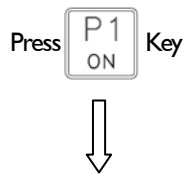

```

Power voltage: 24.0
P1 cycle and timer :
cycle: 000000
Timer: 00000000
P2 cycle and timer :
cycle: 000000
Timer: 00000000

I.1 operating
page up page down
  
```

Press “PI ON” key, PI Outlet will dispense grease continuously. Delivered volume of Outlet depends on model of Lubricator.



```

Power voltage: 24.0
P1 cycle and timer :
cycle: 000001
Timer: 00000000
P2 cycle and timer :
cycle: 000000
Timer: 00000000

I.2 operating
page up page down
  
```





Power voltage: 24.0
 P1 cycle and timer :
 cycle: 000002
 Timer: 0000000
 P2 cycle and timer :
 cycle: 000000
 Timer: 0000000

1.1 operating

page up page down



Power voltage: 24.0
 P1 cycle and timer :
 cycle: 000003
 Timer: 0000000
 P2 cycle and timer :
 cycle: 000000
 Timer: 0000000

page up page down

Press “P1 OFF” key, Pump P1 outlet will stop dispensing grease continuously.

(2) Press Pump P2 on for continuous grease dispensing.



Power voltage: 24.0
 P1 cycle and timer :
 cycle: 000000
 Timer: 0000000
 P2 cycle and timer :
 cycle: 000000
 Timer: 0000000

2.1 operating

page up page down

Press “P2 ON” key, Pump P2 Outlet will dispense grease continuously. Delivered volume of Outlet depends on model of Lubricator.





Power voltage: 24.0
 P1 cycle and timer :
 cycle: 000000
 Timer: 000000
 P2 cycle and timer :
 cycle: 000001
 Timer: 000000
 `

2.2 operating

⏪page up⏩page down



Power voltage: 24.0
 P1 cycle and timer :
 cycle: 000000
 Timer: 000000
 P2 cycle and timer :
 cycle: 000002
 Timer: 000000

2.1 operating

⏪page up⏩page down



Press  Key

Power voltage: 24.0
 P1 cycle and timer :
 cycle: 000000
 Timer: 000000
 P2 cycle and timer :
 cycle: 000003
 Timer: 000000

⏪page up⏩page down

Press “PI OFF” key, Pump P1 outlet will stop dispensing grease continuously.



Appendix A - Lubrication Setting

Due to various factors affecting the lubricator grease volume, APEX recommends lubrication volume and each model lubricator setting method for reference. Every lubricator output has single lubrication point.

Module No.	Average Speed	Output grease dispense volume
5	5 m/s	0.3 cm ³ / 24h

AppendixA-I PLC mode 0 Control

For every 24 hours, PLC sends the correct control signal to lubricator power plug PIN 2, Lubricator will dispense grease 0.3 cm³ / 24h at output. Each lubricator model's control signal is displayed below:

AppendixA-I-1 Model LUG-411

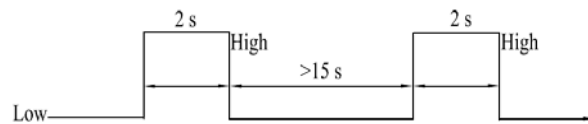

For every 24 hours, Lubricator received the PLC output signal above; outlet I.1 will dispense two strokes with total grease 0.3cm³.

AppendixA-I-2 Model LUG-412

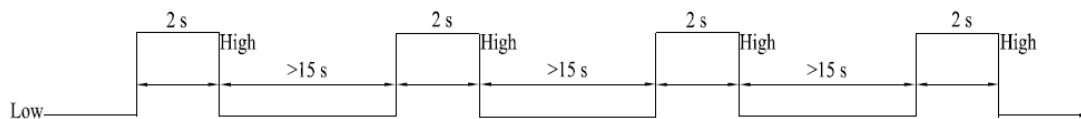

For every 24 hours, Lubricator received the PLC output signal above; outlet I.1 & I.2 will dispense two strokes per outlet with total grease 0.3cm³.

AppendixA-I-3 Model LUG-423

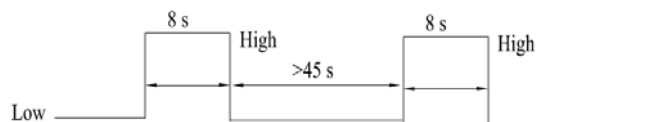

For every 24 hours, Lubricator received the PLC output signal above; outlet I.1, 2.1 & 2.2 will dispense two strokes per outlet with total grease 0.3cm³.



AppendixA-I-4 Model LUG-424

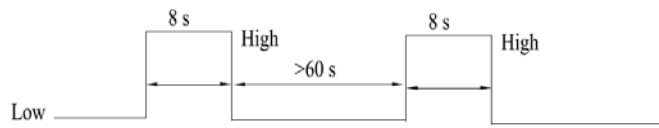

For every 24 hours, Lubricator received the PLC output signal above; outlet 1.1, 1.2, 2.1 & 2.2 will dispense two strokes per outlet with total grease 0.3cm³.

AppendixA-I-5 Model LUG-422

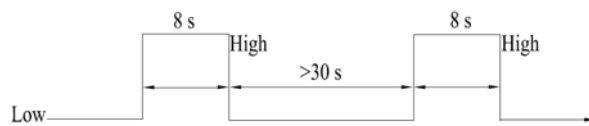

For every 24 hours, Lubricator received the PLC output signal above; outlet 1.1 & 2.1 will dispense two strokes per outlet with total grease 0.3cm³.



AppendixA-2 TIMER mode I Control

Lubricator control mode can be changed from selecting TIMER Mode in Hand-Set.
For every 24 hours, Lubricator will dispense grease 0.3 cm³ / 24h at output. An example illustrated below showing each lubricator model's operation.

AppendixA-2-1 Model LUG-411

```

Mode Selection : 1
0:PLC 1:TIMER 2::PLC
PI cycle : 001 days
00 hours 00 minutes
PI motion : 02 times
P2 cycle : 000 days
00 hours 00 minutes
P2 motion : 01 times

page up page down

```

Set 1 in selection mode, Key in PI cycle 1 day and Key in PI motion 2 strokes. For every 24 hour, Lubricator outlet 1.1 dispenses 2 strokes with grease 0.3 cm³.

AppendixA-2-2 Model LUG-412

```

Mode Selection : 1
0:PLC 1:TIMER 2::PLC
PI cycle : 001 days
00 hours 00 minutes
PI motion : 04 times
P2 cycle : 000 days
00 hours 00 minutes
P2 motion : 01 times

page up page down

```

Set 1 in selection mode, Set PI cycle 1 day and PI motion 4 strokes. For every 24 hour, Lubricator outlet 1.1 & 1.2 dispenses 2 strokes per outlet with grease 0.3 cm³.



AppendixA-2-3 Model LUG-423

```

Mode Selection : 1
0 : PLC 1 : TIMER 2 : PLC
PI cycle : 001 days
00 hours 00 minutes
PI motion : 02 times
P2 cycle : 001 days
00 hours 00 minutes
P2 motion : 04 times

page up page down

```

Set 1 in selection mode, Set PI cycle 1 day and PI motion 2 strokes, Set P2 cycle 1 day and P2 motion 4 strokes. For every 24 hour, Lubricator outlet 1.1 dispenses 2 strokes with grease 0.3 cm³ and outlet 2.1 & 2.2 dispenses 2 strokes per outlet with grease 0.3 cm³.

AppendixA-2-4 Model LUG-424

```

Mode Selection : 1
0 : PLC 1 : TIMER 2 : PLC
PI cycle : 001 days
00 hours 00 minutes
PI motion : 04 times
P2 cycle : 001 days
00 hours 00 minutes
P2 motion : 04 times

page up page down

```

Set 1 in selection mode, Set PI cycle 1 day and PI motion 4 strokes, Set P2 cycle 1 day and P2 motion 4 strokes. For every 24 hour, Lubricator outlet 1.1 & 1.2 dispenses 2 strokes per outlet with grease 0.3 cm³ and outlet 2.1 & 2.2 dispenses 2 strokes per outlet with grease 0.3 cm³.

AppendixA-2-5 Model LUG-422

```

Mode Selection : 1
0 : PLC 1 : TIMER 2 : PLC
PI cycle : 001 days
00 hours 00 minutes
PI motion : 02 times
P2 cycle : 001 days
00 hours 00 minutes
P2 motion : 02 times

page up page down

```

Set 1 in selection mode, Set PI cycle 1 day and PI motion 2 strokes, Set P2 cycle 1 day and P2 motion 2 strokes. For every 24 hour, Lubricator outlet 1.1 dispenses 2 strokes with grease 0.3 cm³ and outlet 2.1 dispenses 2 strokes with grease 0.3 cm³.



AppendixA-3 PLC mode 2 Control

The PLC continuously outputs 24V signal to the lubricator power connector PIN2 pin every 24 hours, and the lubricator can be output the required amount of lubricant 0.3 cm³ / 24h. The following is the constant input time of the 24V control signal matched with each type of lubricator.

AppendixA-3-1 Model LUG-411

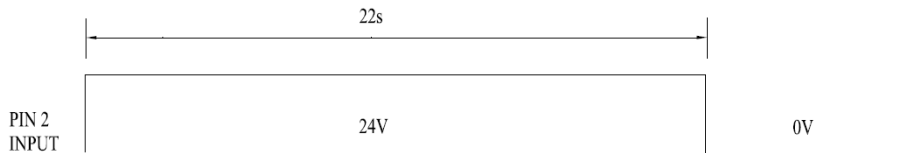

For every 24 hours, Lubricator received the PLC output signal above, the oil outlet of 1.1 will dispense twice, and each output is 0.3 cm³.

AppendixA-3-2 Model LUG-412

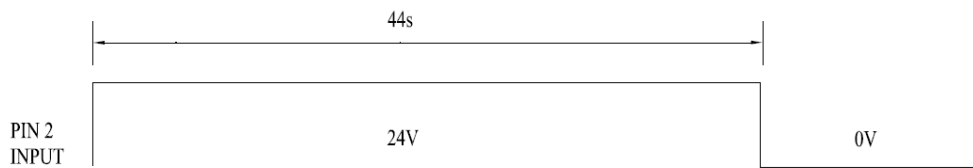

For every 24 hours, Lubricator received the PLC output signal above, the oil outlet of 1.1 and 1.2 will alternate dispenses twice, and each output is 0.3 cm³.

AppendixA-3-3 Model LUG-423

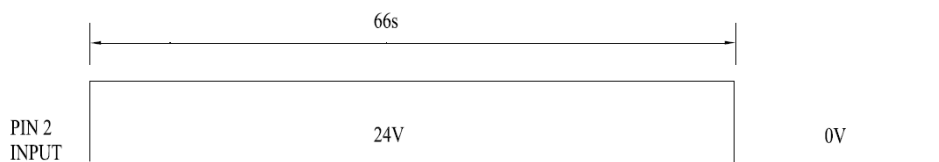

For every 24 hours, Lubricator received the PLC output signal above, the oil outlet of 1.1, 2.1 and 2.2 will alternate dispenses twice, and each output is 0.3 cm³.



AppendixA-3-4 Model LUG-424

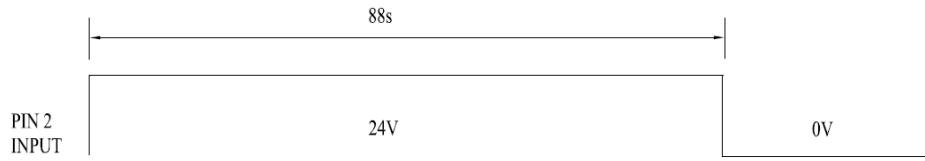

For every 24 hours, Lubricator received the PLC output signal above, the oil outlet of 1.1, 1.2, 2.1 and 2.2 will alternate dispenses twice, and each output is 0.3 cm³.

AppendixA-3-5 Model LUG-422

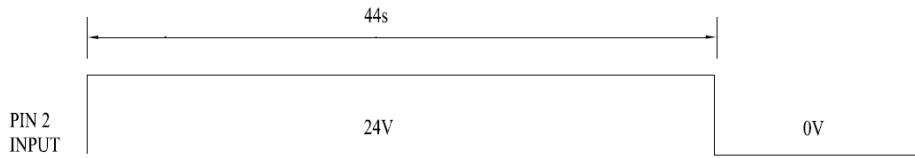

For every 24 hours, Lubricator received the PLC output signal above, the oil outlet of 1.1 and 2.1 will alternate dispenses twice, and each output is 0.3 cm³.



Appendix B - Replacing New Cartridge

Appendix B-1 New Cartridge Replacing

STEP 1.

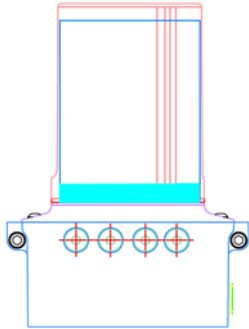

Unplug the power connection.

STEP 2.

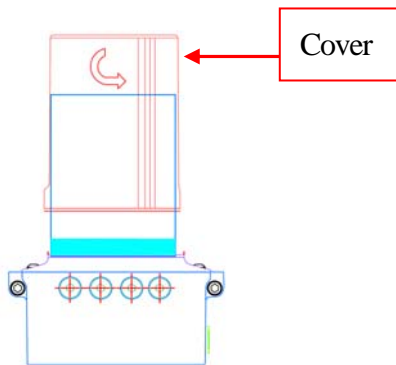

Press the housing and rotate the cover anti-clockwise as arrow and remove black pressure plate & spring.

 Caution



Be aware the spring bouncing or grease splashing when disassemble the cover on lubricator

STEP 3.

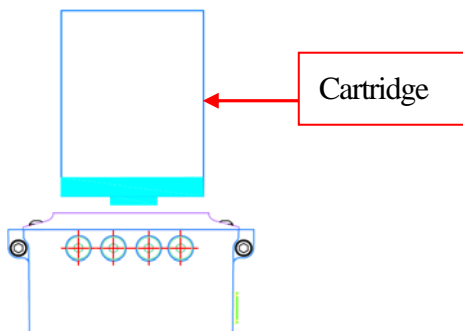

Pull the empty Cartridge upward.



STEP 4.

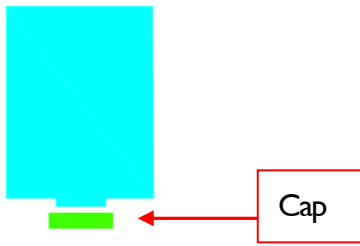

Remove the Cap from the new Cartridge.

STEP 5.

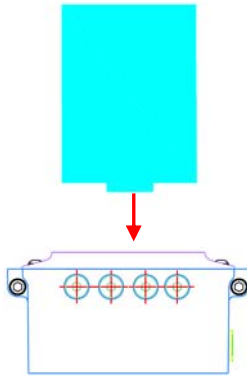

Insert New Cartridge to lubricator

STEP 6.

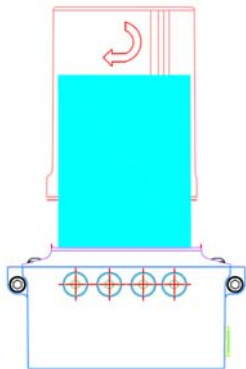

Place black pressure plate and spring onto Cartridge. Press the housing down and rotate clockwise as arrow so as tighten to lubricator.

STEP 7.

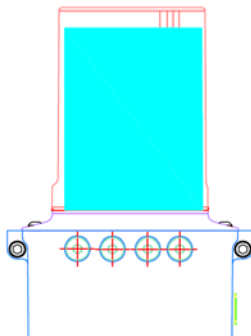

After changing new Cartridge, restart power of Lubricator.

 **Caution**



Please ensure empty Cartridge is properly recycled and prohibit any disposal.



Appendix B-2 Empty cartridge refill oil again.

STEP 1.

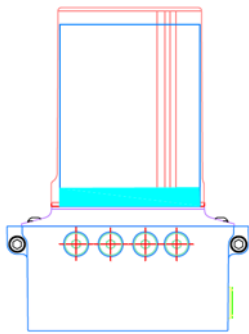

Unplug the power connection.

STEP 2.

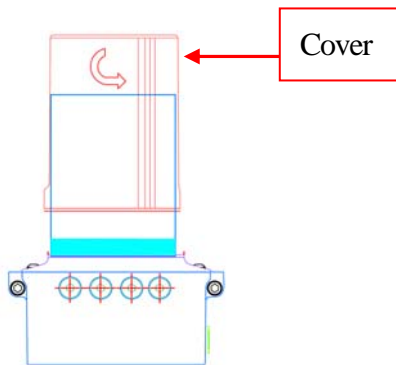

Press the housing and rotate the cover anti-clockwise as arrow and remove black pressure plate & spring.

 Caution



Be aware the spring bouncing or grease splashing when disassemble the cover on lubricator

STEP 3.

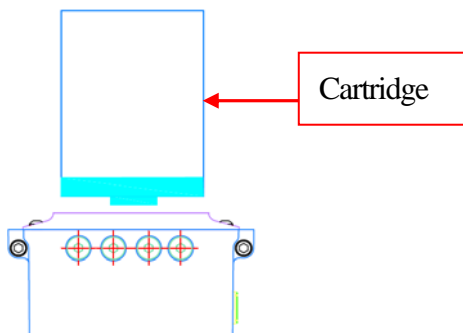

Pull the empty Cartridge upward.



STEP 4.

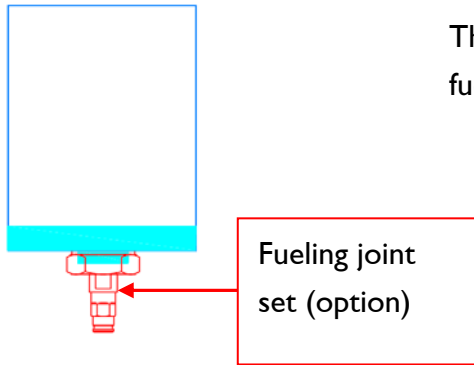

The opening of the cartridge assembly fueling joint set(option)

STEP 5.

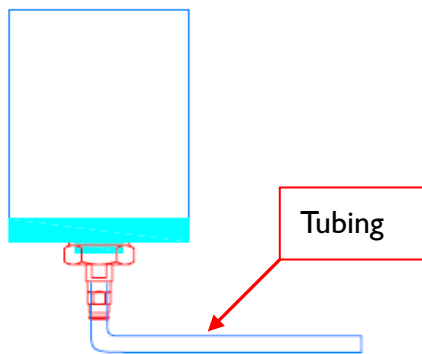

The tubing attached to the corresponding dimension installed to fueling joint set.

STEP 6.

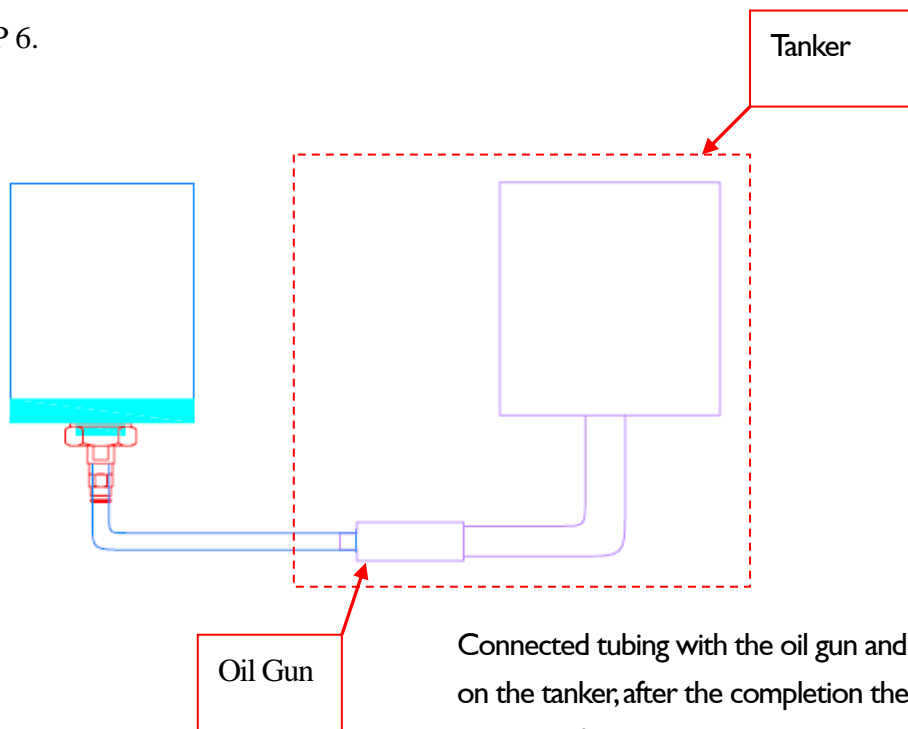

Connected tubing with the oil gun and turn on the tanker; after the completion then start to refill oil.



 Caution



When oil supplement to lubricator, users should pay attention to the tubing and the device has actually complete installed.

STEP 7.



Insert Cartridge to lubricator

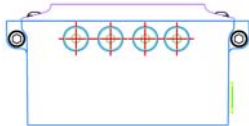

STEP 8.

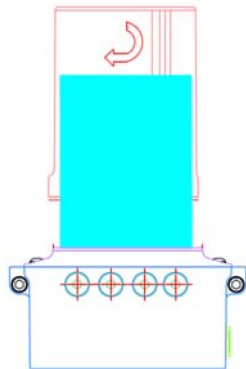

Place black pressure plate and spring onto Cartridge. Press the housing down and rotate clockwise as arrow so as tighten to lubricator.

STEP 9.

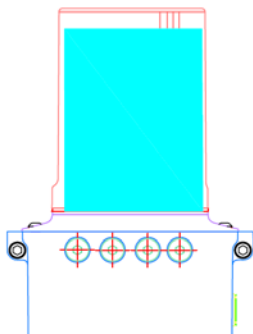

After changing new Cartridge, restart power of Lubricator.



Appendix C- Lubricator Explosion Proof Specification

Lubricator explosion proof is not support to control by manual remote, which from the power cable and mention about all different meaning for each different colored wires. Therefore have to assembly and follow the sequence to process by appendix C-1. Set up for external ground request at least 8 AWG multi cores, to prevent static electricity and appear sparks.

Appendix C-1 side view and power cable wire connect description

LUG-400 Lubricator Side View

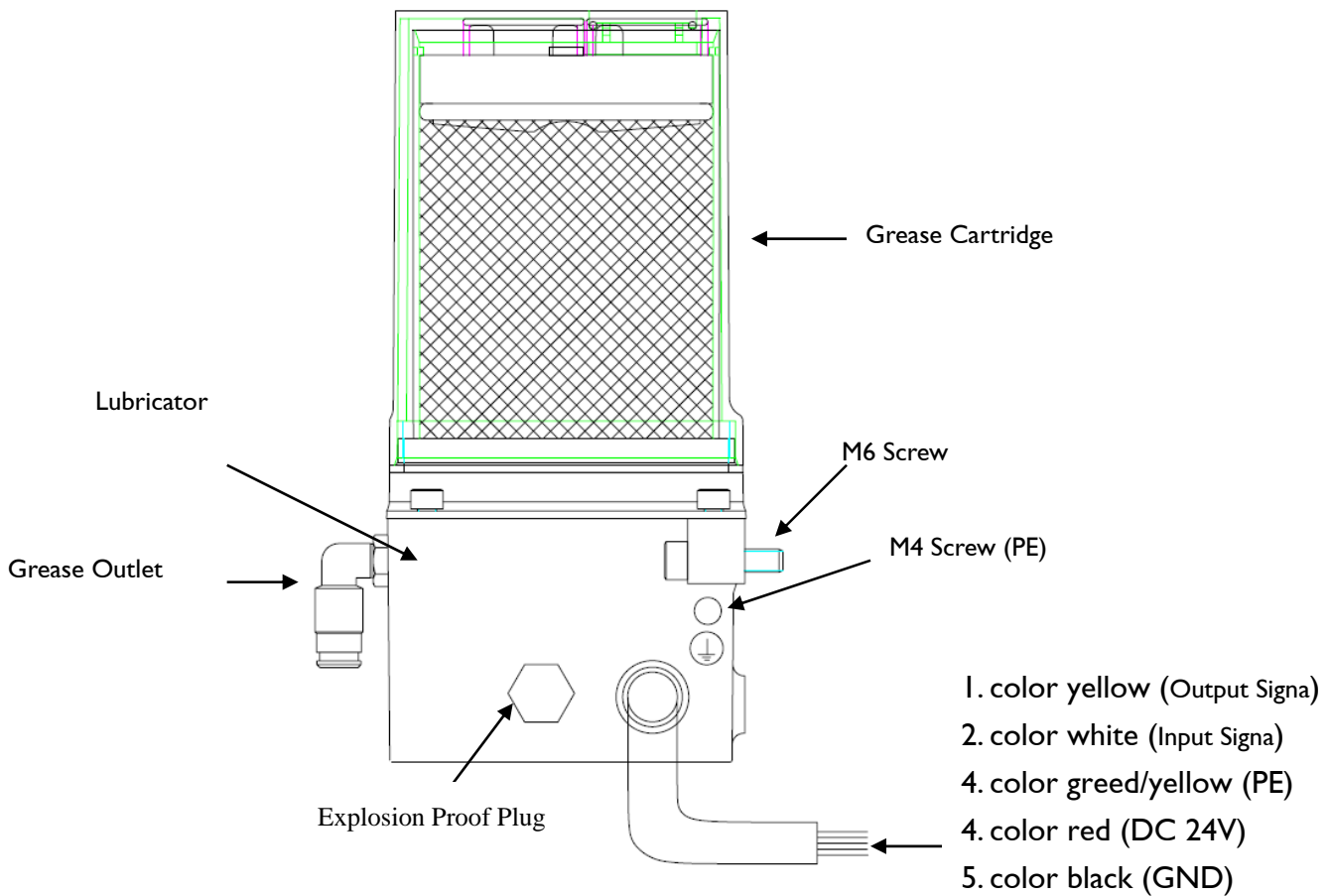



Appendix C-2 Maintenance and Storage

- Do not use a dry cloth to clean or maintain the machine body.
- Use extra caution during dry weather. Relative humidity tends to multiply the accumulation of static charges on any surface.
- Use the equipment only for its intended purpose.
- Incorrect or impermissible use or non-compliance with these instructions invalidates explosion protection.
- No changes to the equipment impairing its explosion protection are permitted.
- Excessive tightening of cable glands and stopping plugs can impair the degree of protection.
- Any damage can invalidate the Ex-protection.



1. WARNING – DO NOT OPEN WHEN AN EXPLOSIVE ATMOSPHERE IS PRESENT.
2. WARNING – POTENTIAL ELECTROSTATIC CHARGING HAZARD – SEE INSTRUCTIONS.
3. WARNING – CABLE GLAND FOR THE CABLES OF POWER CONNECTION OR SYSTEM SETUP SHOULD BE ATEX Ex e tc IP54 CERTIFIED WITH SUITABLE TEMPERATURE RATING.



II 3D Ex tc IIIB T80 C Dc IP5X