



APEX DYNAMICS, INC.

SMART LUBRICATION SYSTEM Original Instruction





Content

I. Safety Information.....	- 1 -
I.1 Overview.....	- 1 -
I.2 Maintenance and Storage	- 1 -
I.3 Safety Regulation	- 1 -
I.4 Hazard Instruction	- 2 -
I.5 Warning Symbol.....	- 2 -
2. Lubrication Specification	- 3 -
2.1 Electrical Specification.....	- 3 -
2.2 Lubricator appearance illustration	- 3 -
2.3 Outlet Position of Each Lubricator Model	- 5 -
2.4 Lubrication Setup Introduction.....	- 7 -
3. PLC Control.....	- 8 -
3.1 Power System Wire	- 8 -
3.1.1 Command Input Signal Wiring	- 9 -
3.2 Various Control Signal of PLC model 0.....	- 10 -
3.2.1 Model LUG-2102.....	- 10 -
3.2.2 Model LUG-2204.....	- 11 -
3.2.3 Model LUG-2306.....	- 13 -
3.2.4 Model LUG-2408.....	- 16 -
3.2.5 Model LUG-2510.....	- 19 -
3.3 Additional Function.....	- 23 -
3.3.1 Filling of Empty Tube with Grease.....	- 23 -
3.3.2 Release Trapped Air.....	- 25 -
3.4 Lubricator Installation Procedure (PLC Mode 0 Control)	- 26 -



- 3.5 Lubricator Troubleshooting..... - 27 -
 - 3.5.1 Waveform of Grease Dispensing..... - 27 -
 - 3.5.2 Waveform Pattern of with or without safety switch..... - 28 -
 - 3.5.3 Waveform Pattern of Malfunction - 29 -
 - 3.5.4 Lubricator PLC Control Output Wiring Instruction - 30 -
- 4. Hand-Set - 31 -
 - 4.1 Power System Wiring (TIMER Control) - 31 -
 - 4.1.1 PLC Machine Power Supply..... - 31 -
 - 4.1.2 Independent Voltage Supply - 32 -
 - 4.2 Instruction of Hand-Set - 33 -
 - 4.3 Function of Hand-Set - 34 -
 - 4.4 Display Screen of Hand-Set - 35 -
 - 4.5 Procedure of Set-Up..... - 39 -
 - 4.6 Instruction of System Mode..... - 43 -
 - 4.6.1 Instruction of TIMER Mode 1 - 43 -
 - 4.6.1.1 Pump 1 dispensing setting..... - 43 -
 - 4.6.1.2 Pump 2 dispensing setting..... - 45 -
 - 4.6.1.3 Pump 3 dispensing setting..... - 47 -
 - 4.6.1.4 Pump 4 dispensing setting..... - 49 -
 - 4.6.1.5 Pump 5 dispensing setting..... - 51 -
 - 4.6.2 Instruction of PLC Mode 2..... - 53 -
 - 4.6.2.1 Model LUG-2102..... - 53 -
 - 4.6.2.2 Model LUG-2204..... - 56 -
 - 4.6.2.3 Model LUG-2306 - 59 -
 - 4.6.2.4 Model LUG-2408..... - 62 -



- 4.6.2.5 Model LUG-2510..... - 65 -
- 4.6.3 Clear Motor Timer Setting - 68 -
- 4.6.4 Description of Error Message..... - 70 -
- 4.6.5 Description of Output Signal Mode - 72 -
- 4.6.6 TIMER Mode I Control Output Wiring Instruction - 74 -
- 4.6.7 Clear Memory Illustration - 75 -
- 4.6.8 Motor Error Detective and Error Counter..... - 77 -
- 4.7 Lubricator Installation Procedure (TIMER mode I Control)..... - 78 -
- 4.8 Lubricator Installation Procedure (PLC mode 2 Control) - 79 -
- 4.9 Instruction of Continuous Oil Dispensing..... - 80 -
- Appendix A Lubrication Setting - 87 -
- AppendixA-1 PLC mode 0 Control..... - 87 -
- AppendixA-1-1 Model LUG-2102..... - 87 -
- AppendixA-1-2 Model LUG-2204..... - 87 -
- AppendixA-1-3 Model LUG-2306..... - 88 -
- AppendixA-1-4 Model LUG-2408..... - 88 -
- AppendixA-1-5 Model LUG-2510..... - 88 -
- AppendixA-2 TIMER Control..... - 89 -
- AppendixA-2-1 Model LUG-2102..... - 89 -
- AppendixA-2-2 Model LUG-2204..... - 89 -
- AppendixA-2-3 Model LUG-2306..... - 90 -
- AppendixA-2-4 Model LUG-2408..... - 90 -
- AppendixA-2-5 Model LUG-2510..... - 91 -
- AppendixA-3 PLC mode 2 Control..... - 92 -



AppendixA-3-1 Model LUG-2102..... - 92 -

AppendixA-3-2 Model LUG-2204..... - 92 -

AppendixA-3-3 Model LUG-2306..... - 93 -

AppendixA-3-4 Model LUG-2408..... - 93 -

AppendixA-3-5 Model LUG-2510..... - 93 -

Appendix B – Replenishing the oil to lubricator..... - 94 -

Appendix C- Lubricator Explosion Proof Specification..... - 96 -

 Appendix C-1 side view and power cable wire connect description..... - 96 -

 Appendix C-2 Maintenance and Storage - 97 -

Manual name	Manual No.
Smart Lubrication System Technical Instruction	LUG2000190716-01



I. Safety Information

I.1 Overview

All personnel must read the entire manual instructions carefully and ensure full understanding the contents before operating, installing and maintaining the SMART Lubrication System. This is to avoid unnecessary danger during operation.

Lubrication System only can be used on pinion or linear guide, it is prohibited for other applications. APEX DYNAMIC can not take the responsibility for the damage under those abnormal usage.

I.2 Maintenance and Storage

- Turn off the power during maintenance and suggest wear gloves and goggles
- Store lubrication system into circulated freely environment
- The grease should be stored in sealed barrel and fix the storage position under room temperature environment
- Avoiding storage in process region, high temperature surface, splashing liquid or on the electrical devices. And consider the suitability for replacement
- Make sure screw the plug on both hand-set and oil cup when lubricator is stop working
- Avoiding inject the prohibitive oil/grease into the lubricator
- Use the funnel or assistant tool when inject the oil into the lubricator to avoid oil leakage to ground or equipment that cause the accident

I.3 Safety Regulation

Please do not ignore Safety Regulation which may cause unnecessary injury or loss of company asset. APEX will not be liable for following situations:

- Incorrect assembly and failure to comply with method of installation, operation, setting-up, maintenance, repair, may result in danger.
- Self-Disassembly of Lubricator
- Self-Modification of Lubricator
- Using Unsuitable Oil
- Using Non-Original Manufacturer Component
- Performing Incorrect method of Trouble shooting



1.4 Hazard Instruction

The Hazard warning is defined as four types of danger level:



Danger refer to hazards with a high risk of severe physical injury or immediate fatality



Warning refers to hazards with moderate risk of severe physical injury or potential fatality.



Caution refers to hazards with a low risk of moderate physical injury.



Note refers to hazards with a slight risk of moderate physical injury.

1.5 Warning Symbol

All users must pay attention to the symbols of Hazard warnings mentioned in Manual as shown in table:

Symbol	Explanation of Symbols
	Hazards due to general causes
	Hazards due to dangerous electrical voltage
	Hazards due to environment pollution
	Wear personal protective equipment (Gloves)
	Wear personal protective equipment (Goggles)



2. Lubrication Specification

2.1 Electrical Specification

Input Power	DC24V \pm 10%
Power Consumption	12W max
Operating Current	I max \leq 500mA
Output / Input	I Set Status Output ; I Set Command Input
Status Output Max. Current	100mA
Command Input Max. Current	50mA
Operating Temperature	-25~70 C
Control mode	PLC mode 0 、TIMER mode 1 、 PLC mode 2

Note: Herewith mode 0 and mode 2 which can be controlled by PLC, the original setup is PLC mode 0. Request Hand-Set connection if needs to change the mode.

2.2 Lubricator appearance illustration

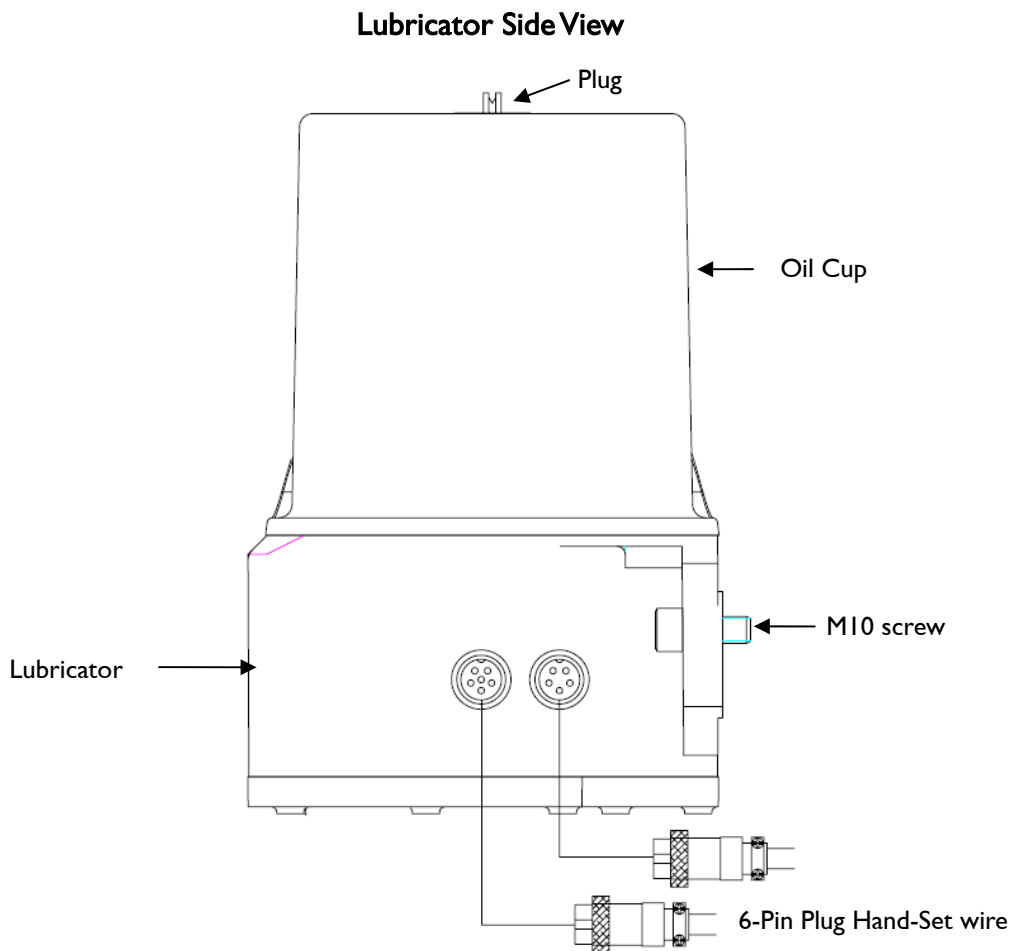



Lubricator Bottom View

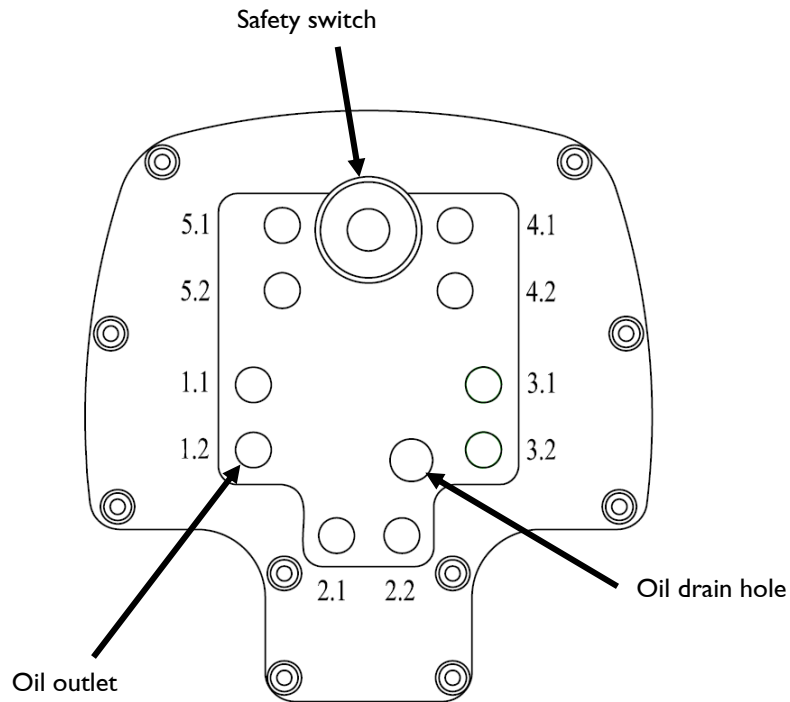

- The lubricator will stop dispensing once the safety switch is removed. This function can prevent the oil leakage from oil outlet during the maintenance operation.

Socket Side View

6-Pin Plug (Hand-Set Wire)



6-Pin Socket on Lubricator



1.Output DC 24V

2.GND

3.I_BUSY

4.RS485

5.RS485

5-Pin Socket (Power Wire)

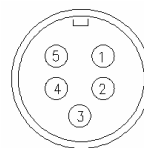

5-Pin Plug on Lubricator

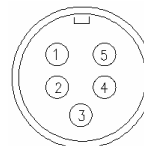

1.Output Signal

2.Input Signal

4.Input DC 24V

5.GND



2.3 Outlet Position of Each Lubricator Model

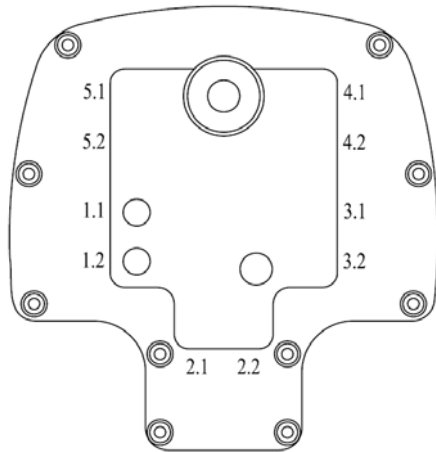

LUG-2102

LUG-2102:

1.1 Outlet : per stroke 0.15cm^3

1.2 Outlet : per stroke 0.15cm^3

Other Oil Outlets are sealed

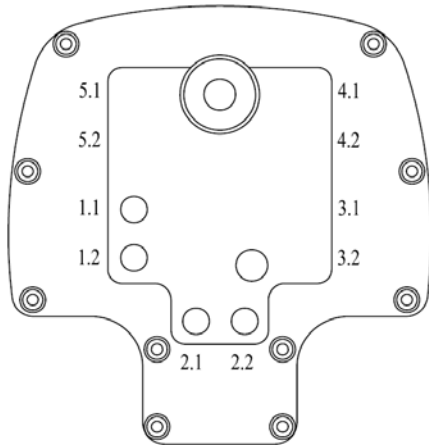

LUG-2204

LUG-2204:

1.1 Outlet : per stroke 0.15cm^3

1.2 Outlet : per stroke 0.15cm^3

2.1 Outlet : per stroke 0.15cm^3

2.2 Outlet : per stroke 0.15cm^3

Other Oil Outlets are sealed

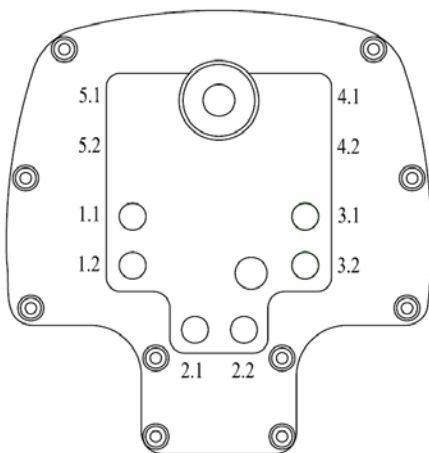

LUG-2306

LUG-2306:

1.1 Outlet : per stroke 0.15cm^3

1.2 Outlet : per stroke 0.15cm^3

2.1 Outlet : per stroke 0.15cm^3

2.2 Outlet : per stroke 0.15cm^3

3.1 Outlet : per stroke 0.15cm^3

3.2 Outlet : per stroke 0.15cm^3

Other Oil Outlets are sealed

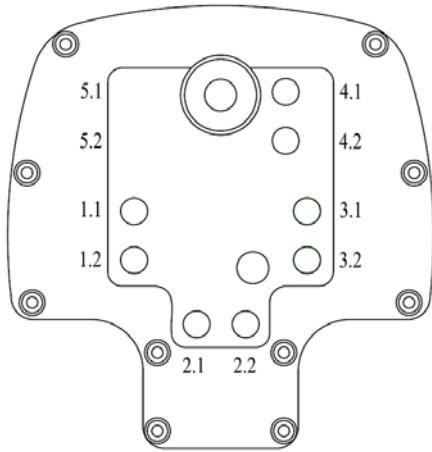

LUG-2408

LUG-2408:

- 1.1 Outlet : per stroke 0.15cm^3
- 1.2 Outlet : per stroke 0.15cm^3
- 2.1 Outlet : per stroke 0.15cm^3
- 2.2 Outlet : per stroke 0.15cm^3
- 3.1 Outlet : per stroke 0.15cm^3
- 3.2 Outlet : per stroke 0.15cm^3
- 4.1 Outlet : per stroke 0.15cm^3
- 4.2 Outlet : per stroke 0.15cm^3

Other Oil Outlets are sealed

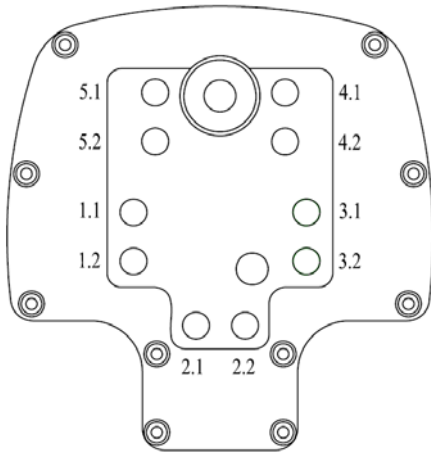

LUG-2510

LUG-2510:

- 1.1 Outlet : per stroke 0.15cm^3
- 1.2 Outlet : per stroke 0.15cm^3
- 2.1 Outlet : per stroke 0.15cm^3
- 2.2 Outlet : per stroke 0.15cm^3
- 3.1 Outlet : per stroke 0.15cm^3
- 3.2 Outlet : per stroke 0.15cm^3
- 4.1 Outlet : per stroke 0.15cm^3
- 4.2 Outlet : per stroke 0.15cm^3
- 5.1 Outlet : per stroke 0.15cm^3
- 5.2 Outlet : per stroke 0.15cm^3

Other Oil Outlets are sealed



2.4 Lubrication Setup Introduction

APEX DYNAMIC, INC. provide the 2 pcs M10 screws and 2 pcs washer for installation. Be aware to install the lubricator in sufficient brightness with well circulated freely environment. And avoid to storage in process region, high temperature surface, splashing liquid or on the electrical devices, also consider the suitability for replacement. Moreover, the tube installation should compatible with system and PLC machine safety standard.

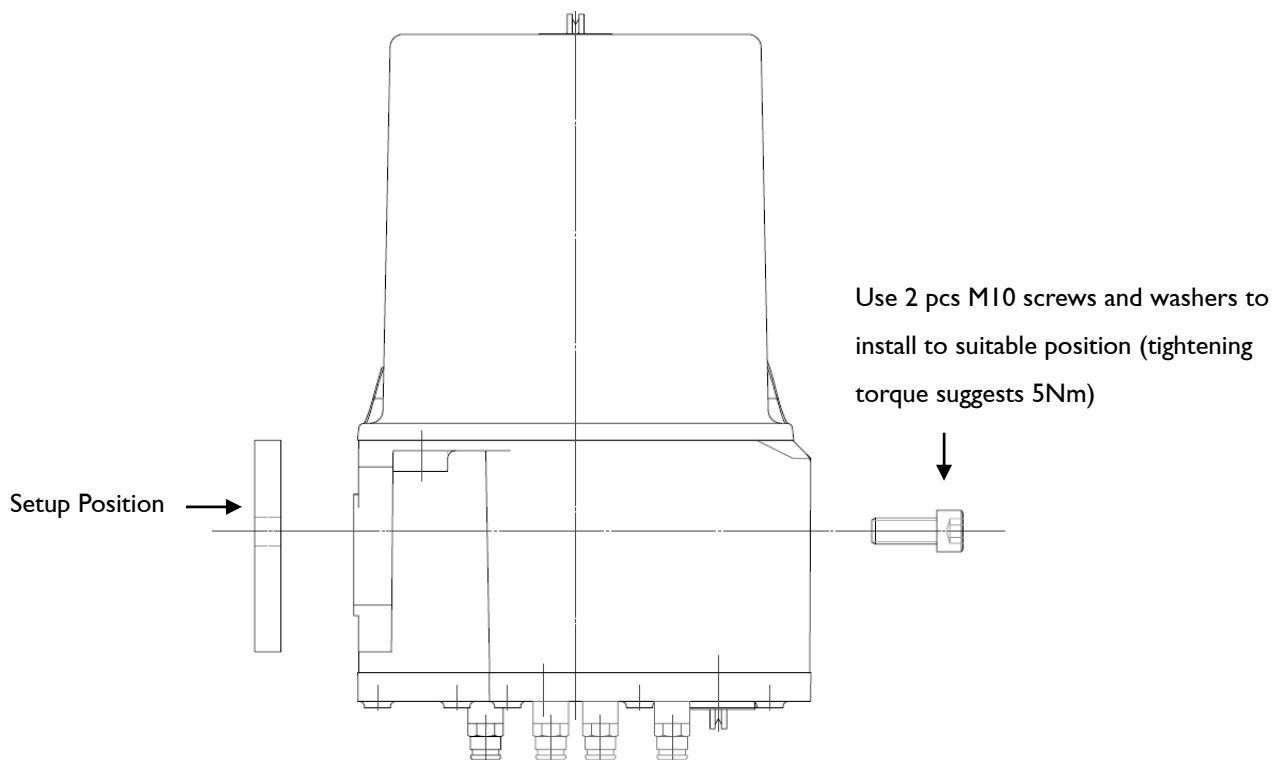



3. PLC Control

PLC transfer different output control signals to Lubricator power plug PIN 2, this can control function of lubricator greasing action, delivered grease volume. The control signal of the Lubricator PLC can be divided into 2 molds as mode 0 and mode 2, the Chapter 3 focuses on mode 0, Mode 2 control signals can refer in section 4.6.2.

3.1 Power System Wire

 **Caution**



APEX provide the power connector, and the user can use the suitable wire to match the connector bore and application. The current resistance at least 1.5A.

The isolation transformer or power supply can produce output DC 24V under control of PLC machine and provided Lubricator with required power DC 24V.

 **Warning**

The isolation transformer or power supply should be certificated product, to avoid the risk of electric shock to the user or equipment

Wiring Diagram of Power System

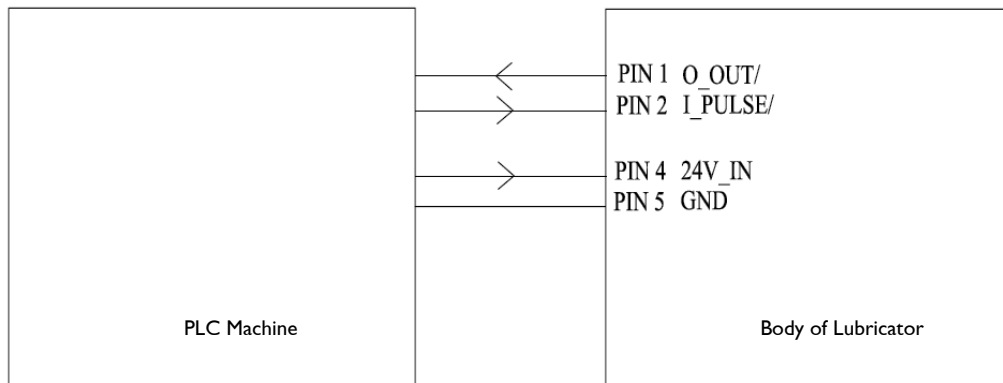

Circuit Protection Switch
(Fuse), Rated Current = 1.1A

 **Caution**



When the input voltage of Lubricator is higher than specified voltage, this will cause damage to the lubricator.



3.1.1 Command Input Signal Wiring

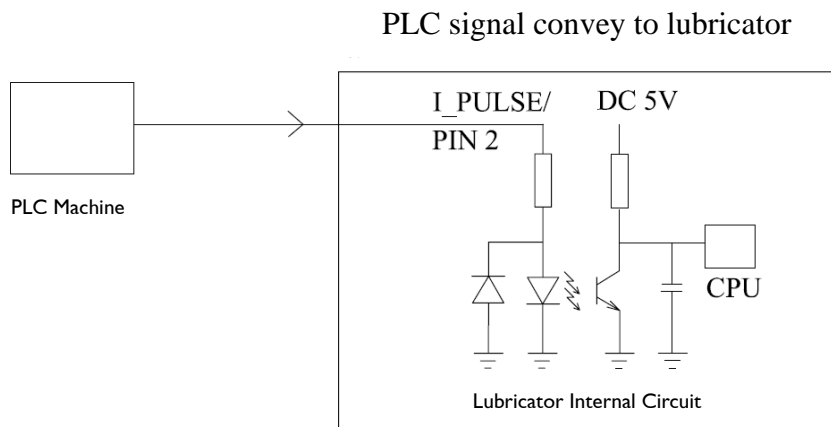

Lubricant Input Electrical Specifications

Input
Rated Voltage : DC 24V ,
Rated Current : 50mA



3.2 Various Control Signal of PLC model 0

Each Lubricator model has control signal and mechanism as illustrated below, LOW as 0V and HIGH as 24V Signal.

3.2.1 Model LUG-2102

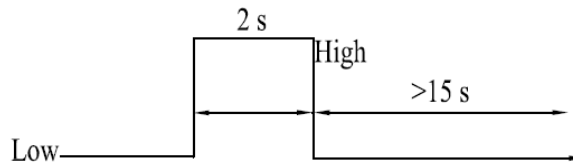
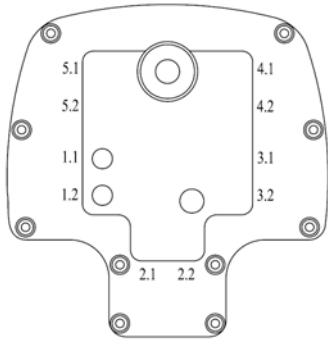

Pump I pushed 1 stroke to outlet 1.1 or 1.2 dispensing 0.15cm³ of oil when Lubricator received one 2s HIGH signal.

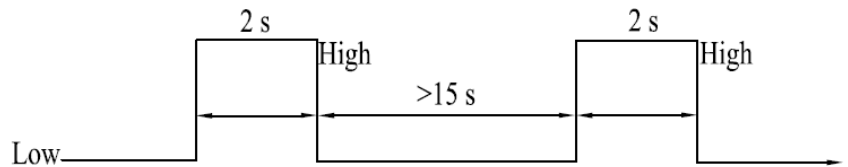
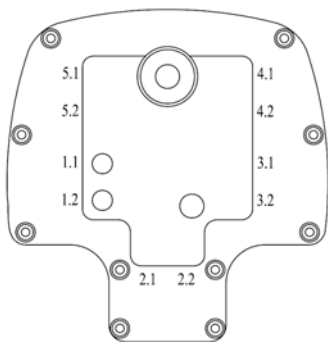

Pump I pushed 1 strokes to outlet 1.1 and 1.2 individually dispensing 2 strokes of 0.15cm³ of oil (total 0.3cm³ grease) when Lubricator received two 2s HIGH signal. Ensure cycle interval of two 2s HIGH signal is at least 15s.



3.2.2 Model LUG-2204

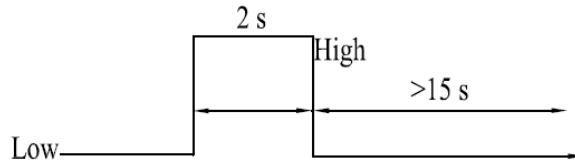
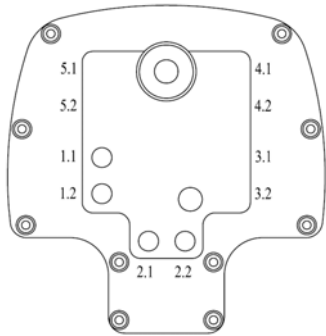

Pump 1 pushed 1 stroke to outlet 1.1 or 1.2 dispensing 0.15cm^3 of oil when Lubricator received one 2s HIGH signal.

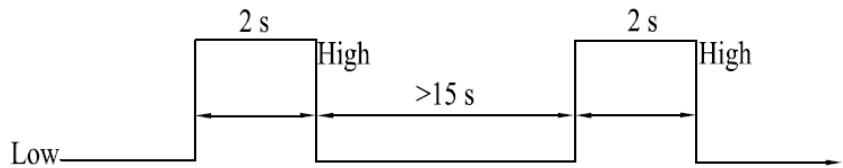
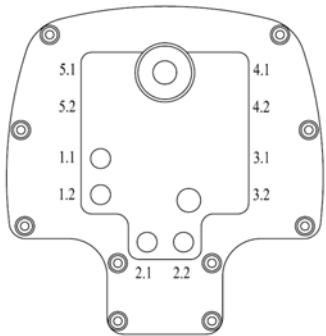

Pump 1 pushed 1 stroke to each outlet 1.1 and 1.2 dispensing 0.15cm^3 of oil individually when Lubricator received two 2s HIGH signal. Ensure cycle interval of two 2s HIGH signal is at least 15s.

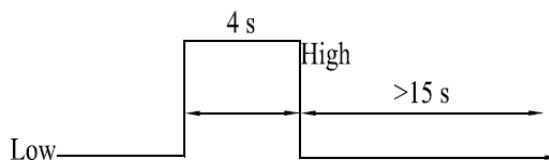
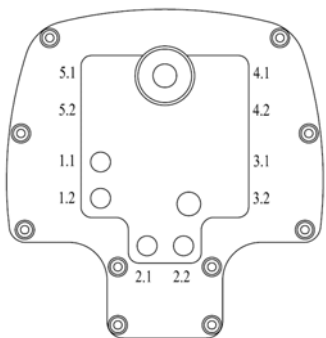

Pump 2 pushed 1 stroke to outlet 2.1 or 2.2 dispensing 0.15cm^3 of oil when Lubricator received one 4s HIGH signal.

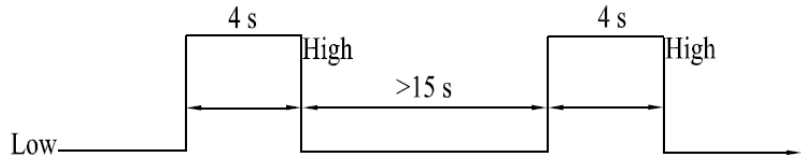
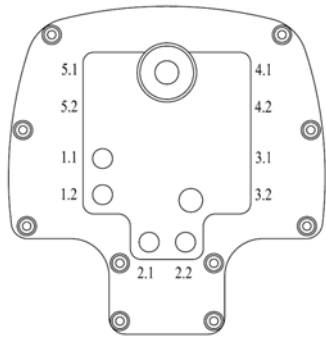

Pump 2 pushed 1 stroke to each outlet 2.1 and 2.2 dispensing 0.15cm³ of oil individually when Lubricator received two 4s HIGH signal. Ensure cycle interval of two 4s HIGH signal is at least 15s.

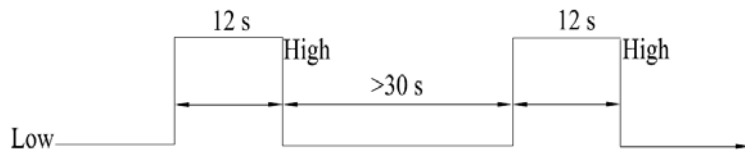
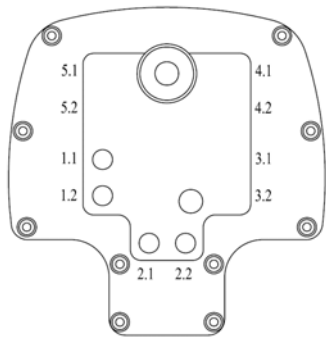

Pump 1 and 2 pushed 1 stroke to each outlet 1.1, 1.2, 2.1 and 2.2 dispensing 0.15cm³ of oil individually when Lubricator received two 12s HIGH signal. Ensure cycle interval of two 12s HIGH signal is at least 30s.



3.2.3 Model LUG-2306

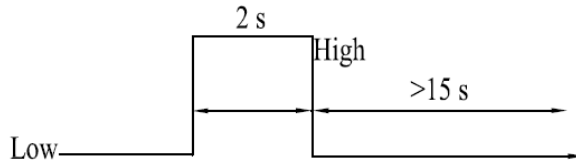
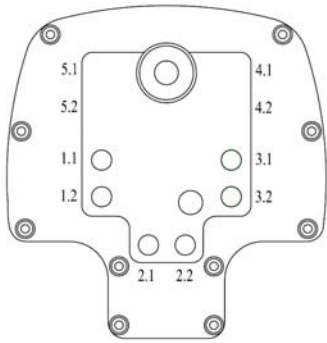

Pump 1 pushed 1 stroke to outlet 1.1 or 1.2 dispensing 0.15cm³ of oil when Lubricator received one 2s HIGH signal.

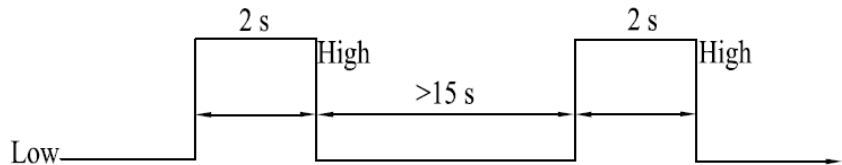
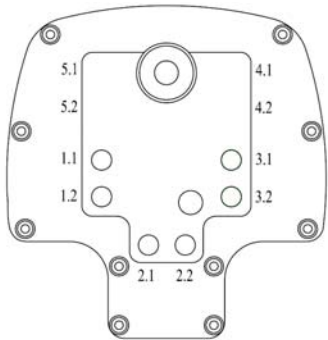

Pump 1 pushed 1 stroke to each outlet 1.1 and 1.2 dispensing 0.15cm³ of oil individually when Lubricator received two 2s HIGH signal. Ensure cycle interval of two 2s HIGH signal is at least 15s.

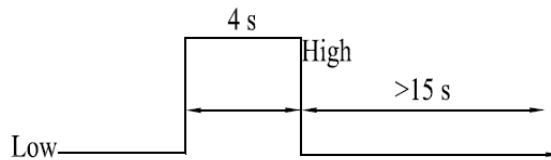
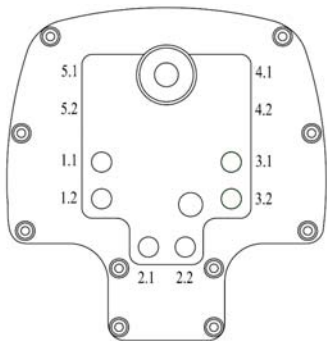

Pump 2 pushed 1 stroke to outlet 2.1 or 2.2 dispensing 0.15cm³ of oil when Lubricator received one 4s HIGH signal.

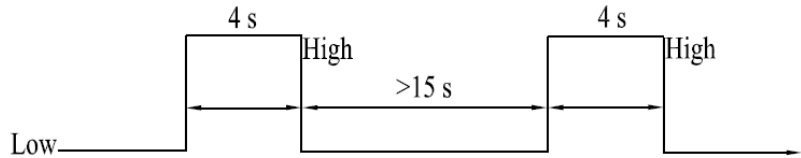
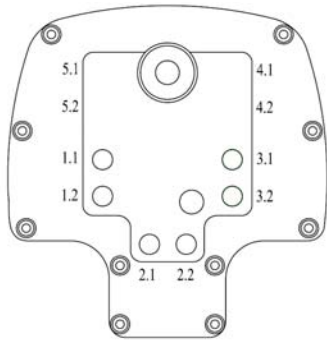

Pump 2 pushed 1 stroke to each outlet 2.1 and 2.2 dispensing 0.15cm³ of oil individually when Lubricator received two 4s HIGH signal. Ensure cycle interval of two 4s HIGH signal is at least 15s.

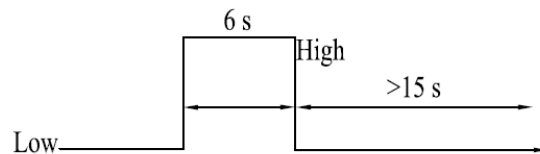
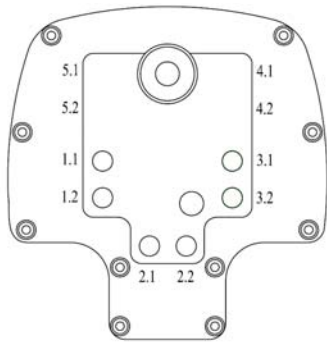

Pump 3 pushed 1 stroke to outlet 3.1 or 3.2 dispensing 0.15cm³ of oil when Lubricator received one 6s HIGH signal.

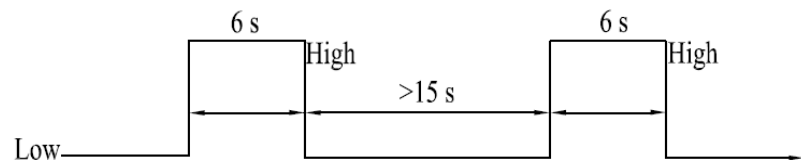
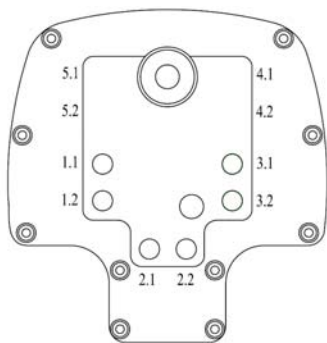

Pump 3 pushed 1 stroke to each outlet 3.1 and 3.2 dispensing 0.15cm³ of oil individually when Lubricator received two 6s HIGH signal. Ensure cycle interval of two 6s HIGH signal is at least 15s.

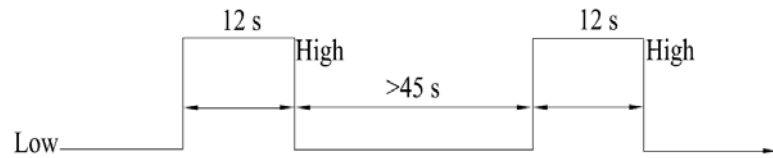
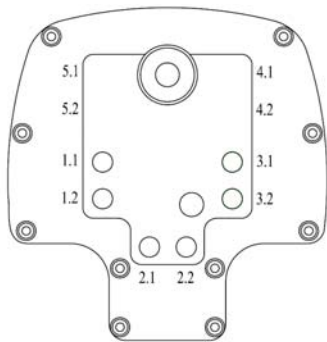

Pump 1, 2 and 3 pushed 1 stroke to each outlet 1.1, 1.2, 2.1, 2.2, 3.1 and 3.2 dispensing 0.15cm^3 of oil individually when Lubricator received two 12s HIGH signal. Ensure cycle interval of two 12s HIGH signal is at least 45s.



3.2.4 Model LUG-2408

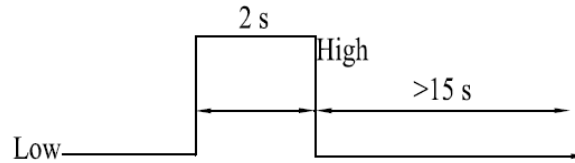
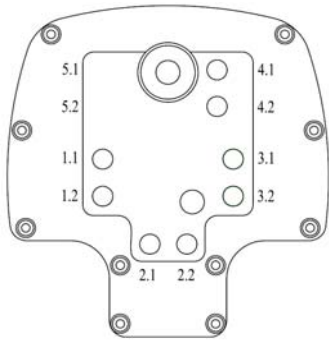

Pump 1 pushed 1 stroke to outlet 1.1 or 1.2 dispensing 0.15cm³ of oil when Lubricator received one 2s HIGH signal.

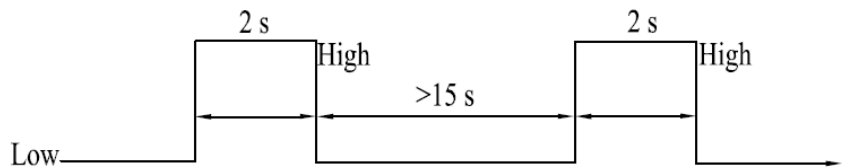
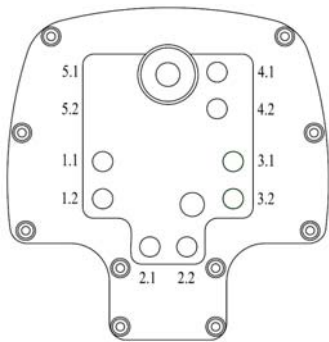

Pump 1 pushed 1 stroke to each outlet 1.1 and 1.2 dispensing 0.15cm³ of oil individually when Lubricator received two 2s HIGH signal. Ensure cycle interval of two 2s HIGH signal is at least 15s.

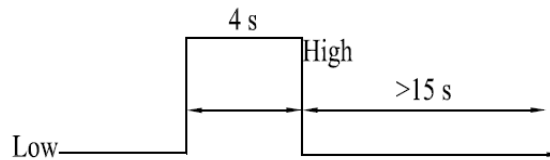
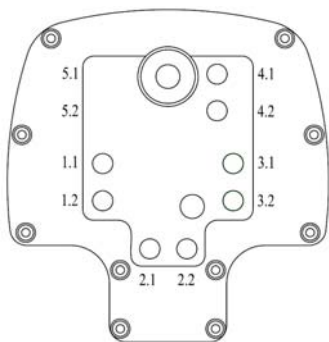

Pump 2 pushed 1 stroke to outlet 2.1 or 2.2 dispensing 0.15cm³ of oil when Lubricator received one 4s HIGH signal.

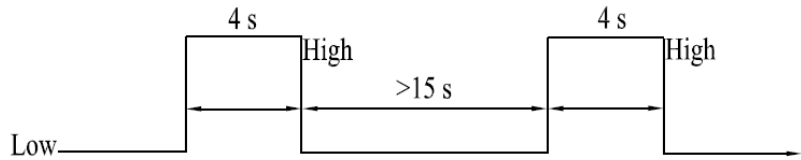
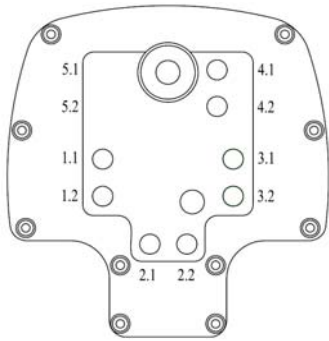

Pump 2 pushed 1 stroke to each outlet 2.1 and 2.2 dispensing 0.15cm³ of oil individually when Lubricator received two 4s HIGH signal. Ensure cycle interval of two 4s HIGH signal is at least 15s.

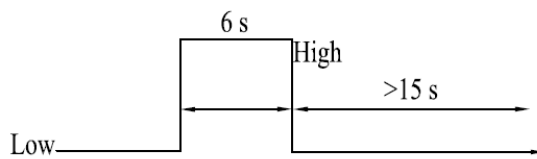
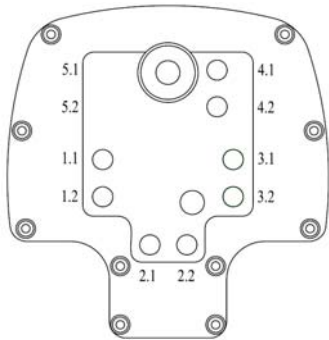

Pump 3 pushed 1 stroke to outlet 3.1 or 3.2 dispensing 0.15cm³ of oil when Lubricator received one 6s HIGH signal.

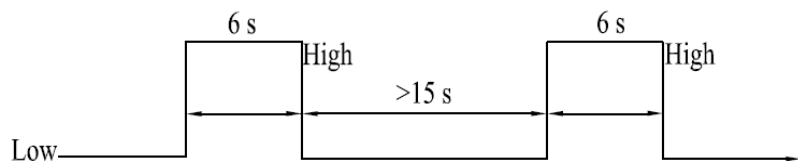
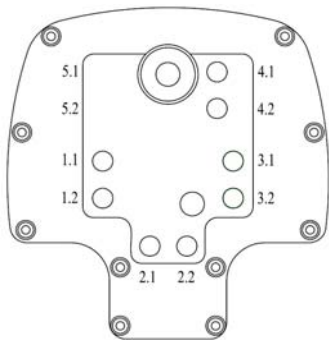

Pump 3 pushed 1 stroke to each outlet 3.1 and 3.2 dispensing 0.15cm³ of oil individually when Lubricator received two 6s HIGH signal. Ensure cycle interval of two 6s HIGH signal is at least 15s.

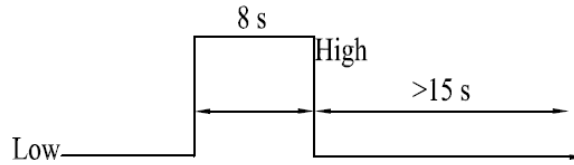
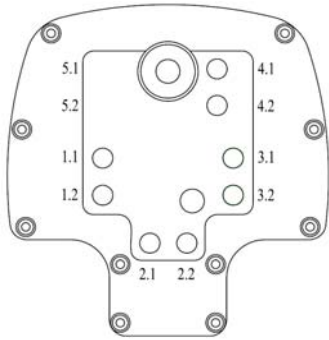

Pump 4 pushed 1 stroke to outlet 4.1 or 4.2 dispensing 0.15cm³ of oil when Lubricator received one 8s HIGH signal.

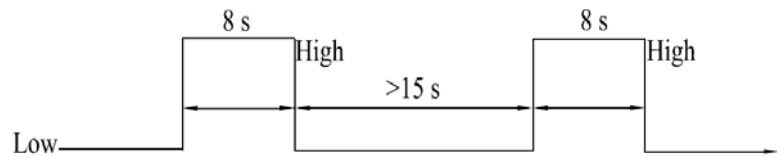
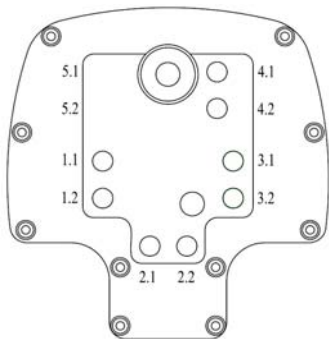

Pump 4 pushed 1 stroke to each outlet 4.1 and 4.2 dispensing 0.15cm³ of oil individually when Lubricator received two 8s HIGH signal. Ensure cycle interval of two 8s HIGH signal is at least 15s.

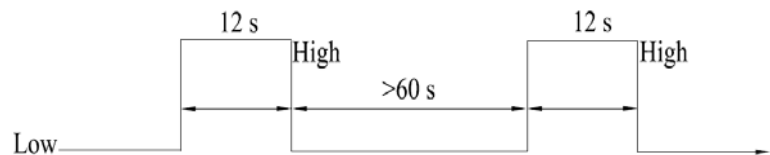
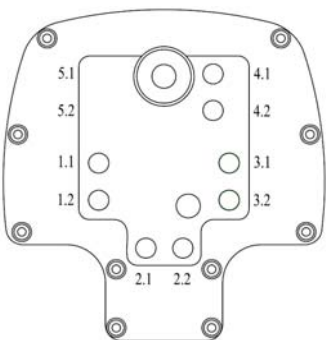

Pump 1, 2, 3 and 4 pushed 1 stroke to each outlet 1.1, 1.2, 2.1, 2.2, 3.1, 3.2, 4.1 and 4.2 dispensing 0.15cm³ of oil individually when Lubricator received two 12s HIGH signal. Ensure cycle interval of two 12s HIGH signal is at least 60s.



3.2.5 Model LUG-2510

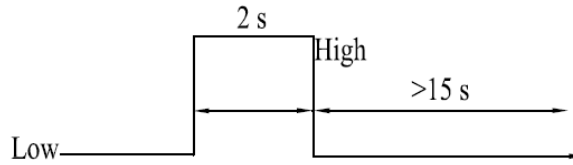
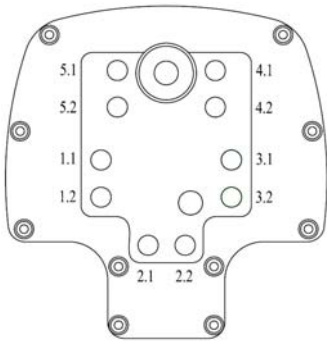

Pump 1 pushed 1 stroke to outlet 1.1 or 1.2 dispensing 0.15cm³ of oil when Lubricator received one 2s HIGH signal.

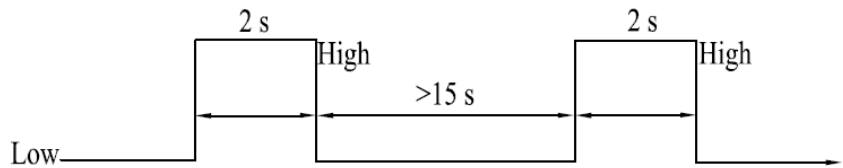
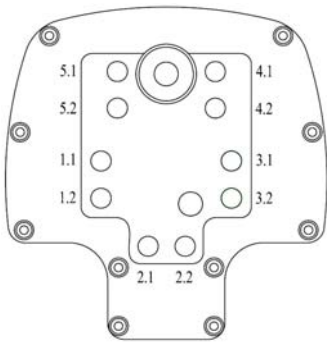

Pump 1 pushed 1 stroke to each outlet 1.1 and 1.2 dispensing 0.15cm³ of oil individually when Lubricator received two 2s HIGH signal. Ensure cycle interval of two 2s HIGH signal is at least 15s.

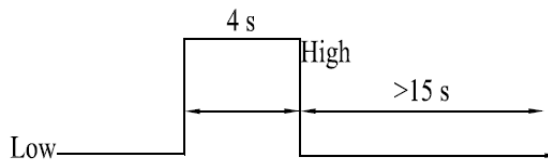
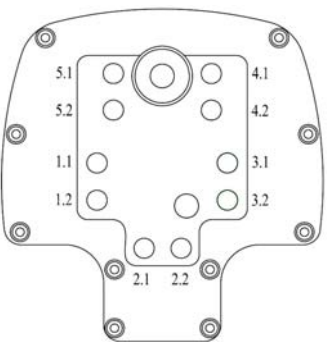

Pump 2 pushed 1 stroke to outlet 2.1 or 2.2 dispensing 0.15cm³ of oil when Lubricator received one 4s HIGH signal.

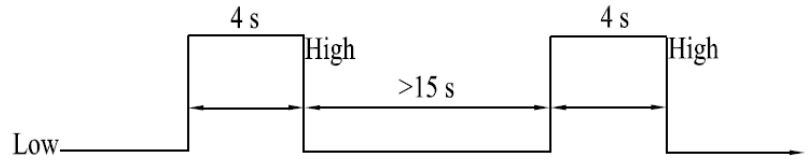
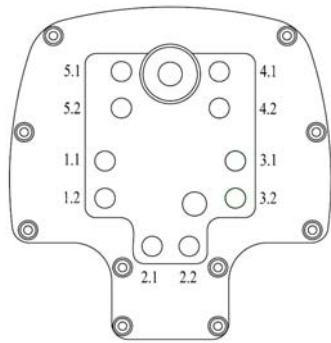

Pump 2 pushed 1 stroke to each outlet 2.1 and 2.2 dispensing 0.15cm³ of oil individually when Lubricator received two 4s HIGH signal. Ensure cycle interval of two 4s HIGH signal is at least 15s.

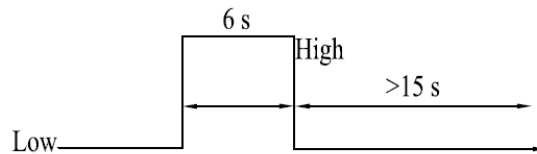
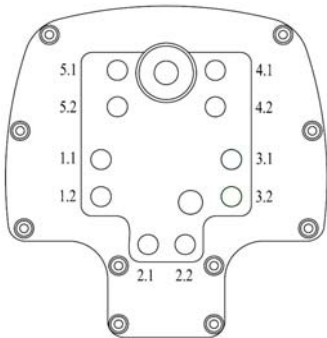

Pump 3 pushed 1 stroke to outlet 3.1 or 3.2 dispensing 0.15cm³ of oil when Lubricator received one 6s HIGH signal.

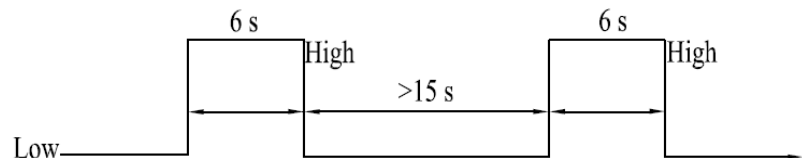
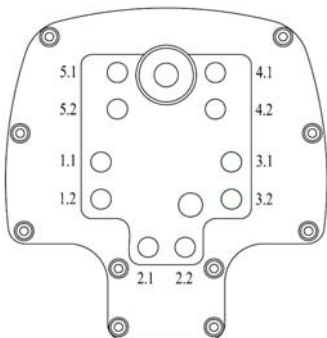

Pump 3 pushed 1 stroke to each outlet 3.1 and 3.2 dispensing 0.15cm³ of oil individually when Lubricator received two 6s HIGH signal. Ensure cycle interval of two 6s HIGH signal is at least 15s.

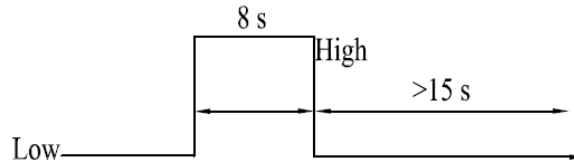
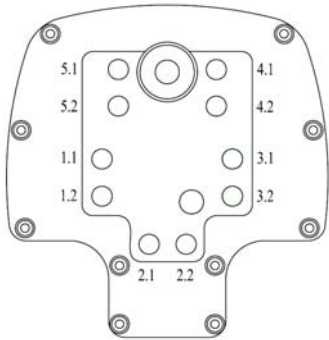

Pump 4 pushed 1 stroke to outlet 4.1 or 4.2 dispensing 0.15cm³ of oil when Lubricator received one 8s HIGH signal.

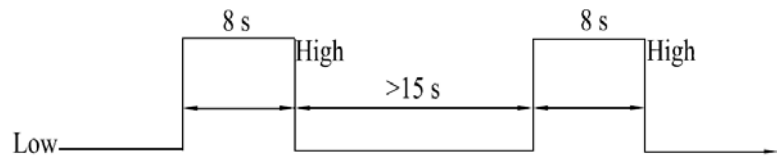
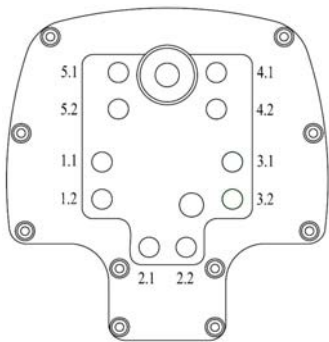

Pump 4 pushed 1 stroke to each outlet 4.1 and 4.2 dispensing 0.15cm³ of oil individually when Lubricator received two 8s HIGH signal. Ensure cycle interval of two 8s HIGH signal is at least 15s.

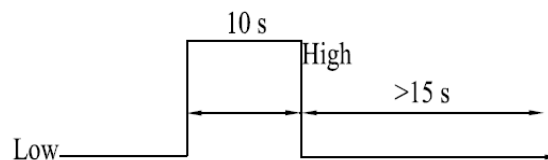
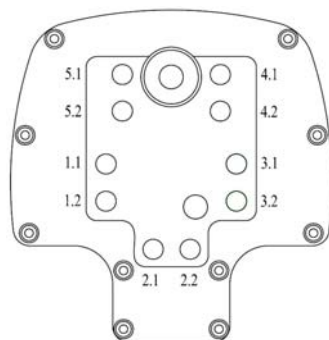

Pump 5 pushed 1 stroke to outlet 5.1 or 5.2 dispensing 0.15cm³ of oil when Lubricator received one 10s HIGH signal.

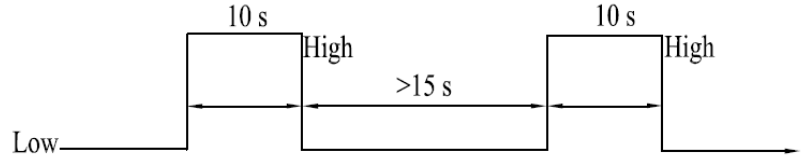
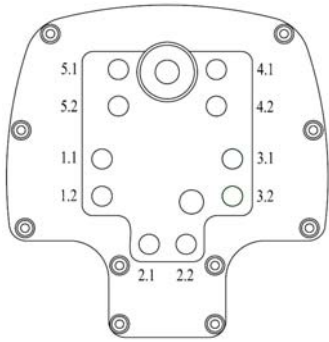

Pump 5 pushed 1 stroke to each outlet 5.1 and 5.2 dispensing 0.15cm³ of oil individually when Lubricator received two 10s HIGH signal. Ensure cycle interval of two 10s HIGH signal is at least 15s.

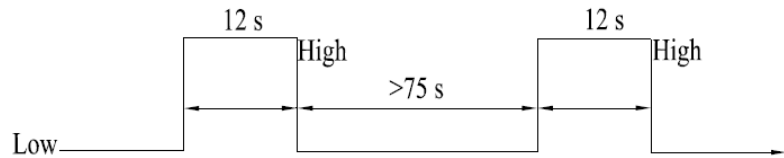
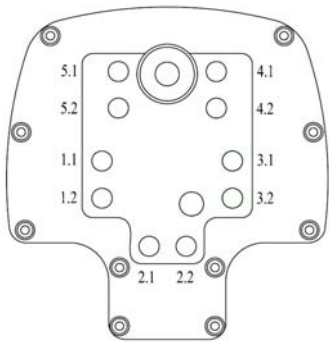

Pump 1, 2, 3, 4 and 5 pushed 1 stroke to each outlet 1.1, 1.2, 2.1, 2.2, 3.1, 3.2, 4.1, 4.2, 5.1 and 5.2 dispensing 0.15cm³ of oil individually when Lubricator received two 12s HIGH signal. Ensure cycle interval of two 12s HIGH signal is at least 75s.



3.3 Additional Function

3.3.1 Filling of Empty Tube with Grease

May use PLC output 14s HIGH signal after completed installing Lubricator Tube to perform oiling continuously and user use this function to allow empty tube filled with oil. After receiving the PLC signal of each Lubricator model, volume of oil supply to each outlet as follows:

LUG-2102:

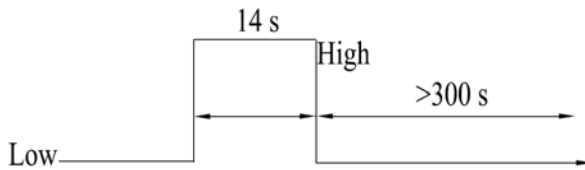

1.1 Outlet : $10 \times 0.15\text{cm}^3 = 1.5\text{cm}^3$

1.2 Outlet : $10 \times 0.15\text{cm}^3 = 1.5\text{cm}^3$

LUG-2204:

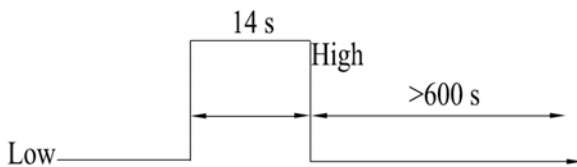

1.1 Outlet : $10 \times 0.15\text{cm}^3 = 1.5\text{cm}^3$

2.1 Outlet : $10 \times 0.15\text{cm}^3 = 1.5\text{cm}^3$

1.2 Outlet : $10 \times 0.15\text{cm}^3 = 1.5\text{cm}^3$

2.1 Outlet : $10 \times 0.15\text{cm}^3 = 1.5\text{cm}^3$

LUG-2306:

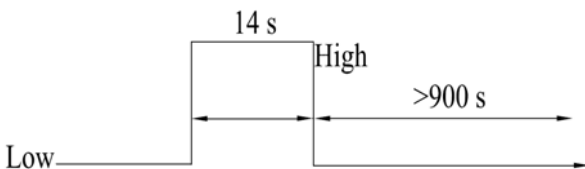

1.1 Outlet : $10 \times 0.15\text{cm}^3 = 1.5\text{cm}^3$

3.1 Outlet : $10 \times 0.15\text{cm}^3 = 1.5\text{cm}^3$

1.2 Outlet : $10 \times 0.15\text{cm}^3 = 1.5\text{cm}^3$

3.2 Outlet : $10 \times 0.15\text{cm}^3 = 1.5\text{cm}^3$

2.1 Outlet : $10 \times 0.15\text{cm}^3 = 1.5\text{cm}^3$

2.2 Outlet : $10 \times 0.15\text{cm}^3 = 1.5\text{cm}^3$



LUG-2408:

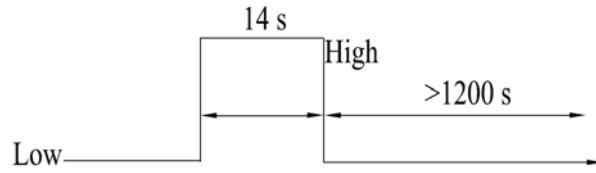

1.1 Outlet : $10 \times 0.15\text{cm}^3 = 1.5\text{cm}^3$

1.2 Outlet : $10 \times 0.15\text{cm}^3 = 1.5\text{cm}^3$

2.1 Outlet : $10 \times 0.15\text{cm}^3 = 1.5\text{cm}^3$

2.2 Outlet : $10 \times 0.15\text{cm}^3 = 1.5\text{cm}^3$

3.1 Outlet : $10 \times 0.15\text{cm}^3 = 1.5\text{cm}^3$

3.2 Outlet : $10 \times 0.15\text{cm}^3 = 1.5\text{cm}^3$

4.1 Outlet : $10 \times 0.15\text{cm}^3 = 1.5\text{cm}^3$

4.2 Outlet : $10 \times 0.15\text{cm}^3 = 1.5\text{cm}^3$

LUG-2510:

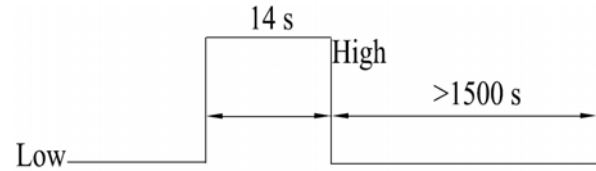

1.1 Outlet : $10 \times 0.15\text{cm}^3 = 1.5\text{cm}^3$

1.2 Outlet : $10 \times 0.15\text{cm}^3 = 1.5\text{cm}^3$

2.1 Outlet : $10 \times 0.15\text{cm}^3 = 1.5\text{cm}^3$

2.2 Outlet : $10 \times 0.15\text{cm}^3 = 1.5\text{cm}^3$

3.1 Outlet : $10 \times 0.15\text{cm}^3 = 1.5\text{cm}^3$

3.2 Outlet : $10 \times 0.15\text{cm}^3 = 1.5\text{cm}^3$

4.1 Outlet : $10 \times 0.15\text{cm}^3 = 1.5\text{cm}^3$

4.2 Outlet : $10 \times 0.15\text{cm}^3 = 1.5\text{cm}^3$

5.1 Outlet : $10 \times 0.15\text{cm}^3 = 1.5\text{cm}^3$

5.2 Outlet : $10 \times 0.15\text{cm}^3 = 1.5\text{cm}^3$



3.3.2 Release Trapped Air

Use PLC output I4s HIGH signal to perform oiling continuously and remove trapped air in internal tube.

LUG-2102:

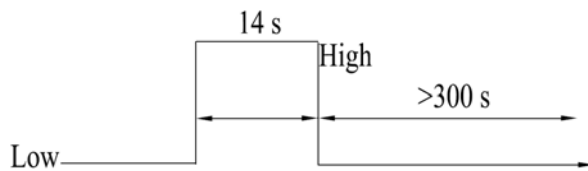

LUG-2408:

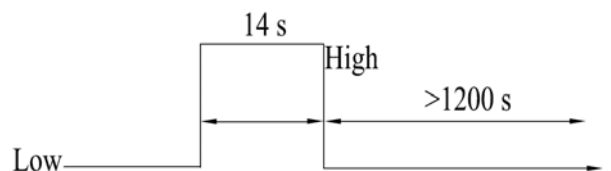

LUG-2204:

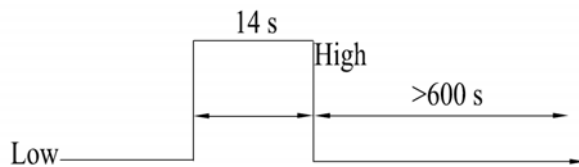

LUG-2510:

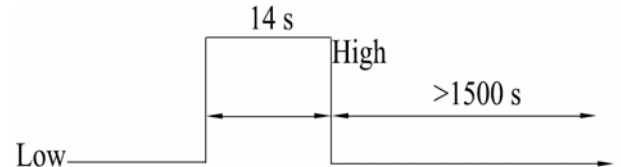

LUG-2306:

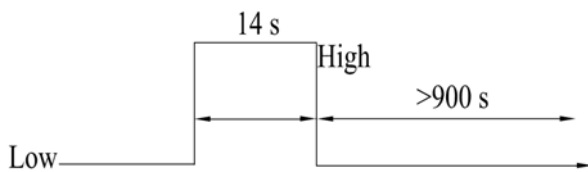



3.4 Lubricator Installation Procedure (PLC Mode 0 Control)

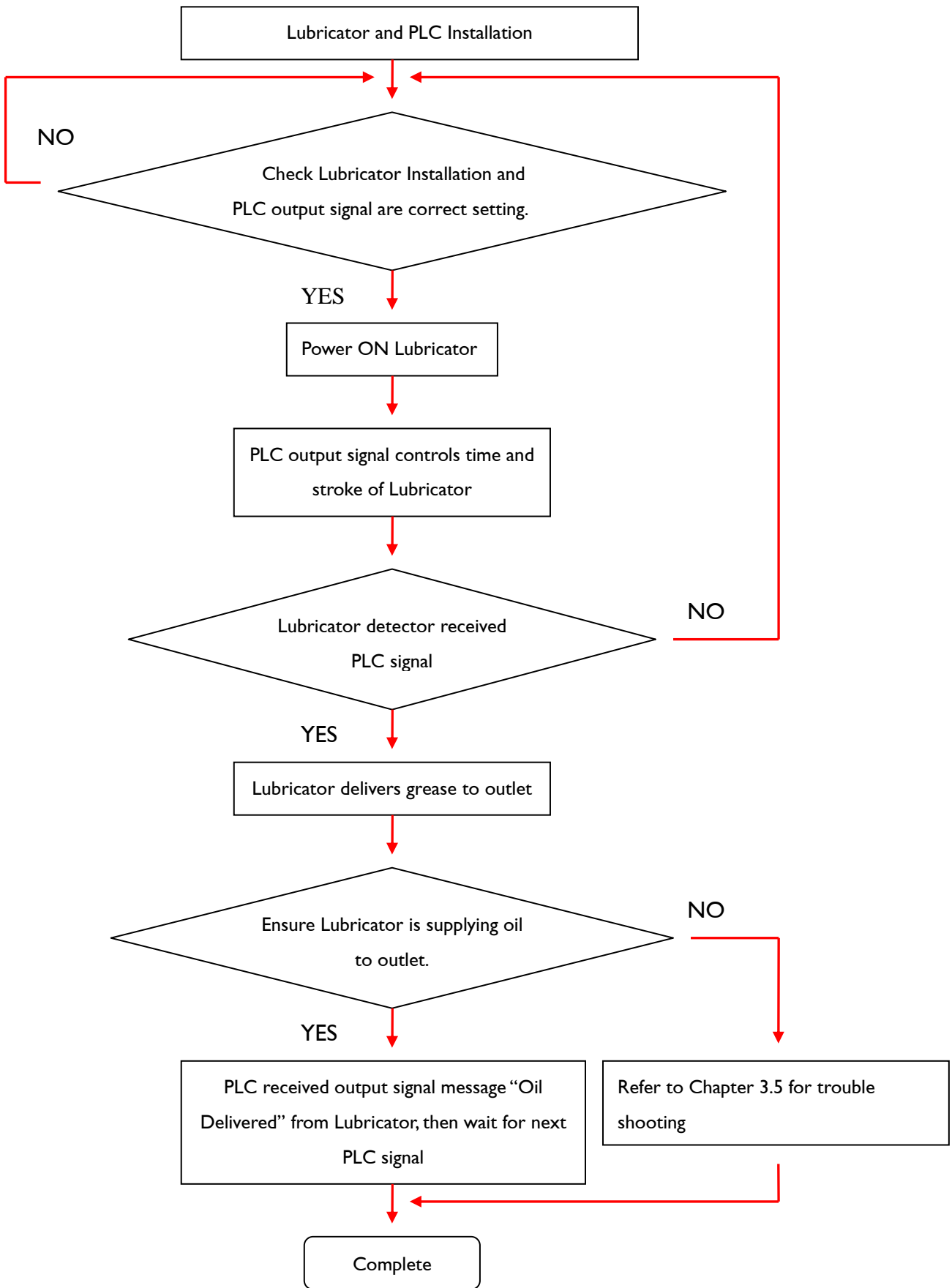



3.5 Lubricator Troubleshooting

PIN 1 of Lubricator power supply connected to PLC machine, the PIN 1 will output different signal to PLC, so that PLC knows status of lubricator. Lubricator output signal with the corresponding information as follows. Displaying 0V signal as LOW, 24V signal as HIGH.

3.5.1 Waveform of Grease Dispensing



Power ON Lubricator, PIN 1 output signal as HIGH, at this time Lubricator then will receive the PLC command.

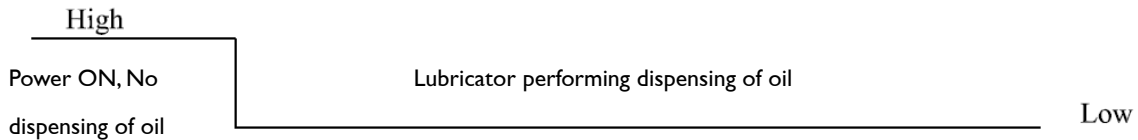

When Pin 1 output signal changed from HIGH to LOW, this means PLC knows Lubricator is performing dispensing of oil to outlet and at this moment Lubricator will ignore PLC command.

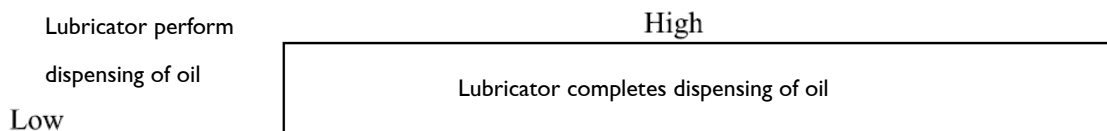

When Pin 1 output signal change from LOW to HIGH, this means PLC knows Lubricator completes dispensing of oil to outlet.



3.5.2 Waveform Pattern of with or without safety switch

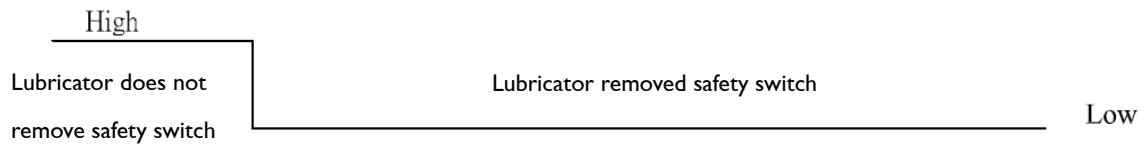

When Lubricator power ON, and the safety switch have been removed, the output signal change from HIGH to LOW on PIN I. At this moment, Lubricator will ignore PLC command. This function can be used to avoid dispensing of oil during maintenance.

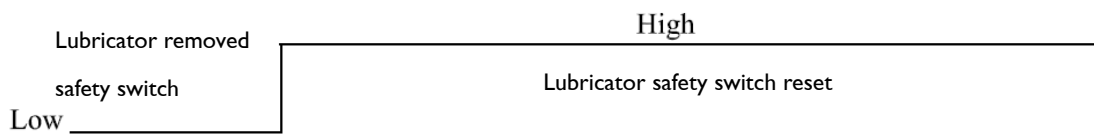

Once the safety switch has been reset, the output signal change from LOW to HIGH on PIN I, the lubricator will be restarted at this moment.



3.5.3 Waveform Pattern of Malfunction



Lubricator malfunction, PIN 1 will continue to output LOW signal, at this status, please follow the below table for Lubricator troubleshooting.

Malfunction	Reason	Remedy
Lubricator cannot dispense oil	PA tube filled with oil contains trapped air	Refer chapter 3.3 for trouble shooting
	Lubricator PA tube blocked	Inspect PA tube for foreign particle blockage or tube length is too long.
	Lubricator motor idling	Contact APEX Manufacturer

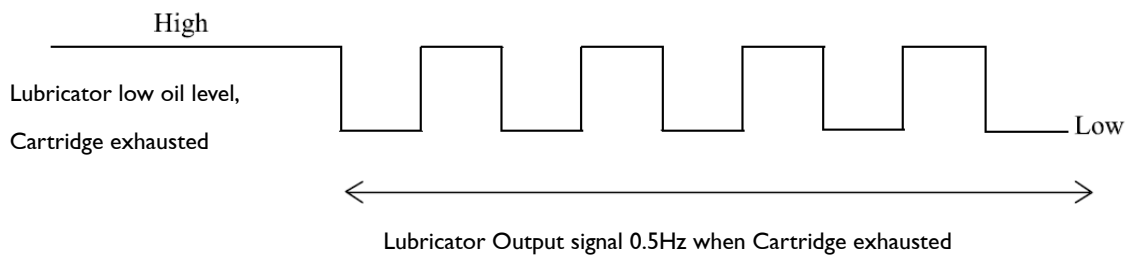

Please follow the below table for troubleshooting when Lubricator cartridge is exhausted, PIN 1 will send output 0.5Hz signal.

Malfunction	Reason	Solution
Lubricator cannot dispense oil	Sensor detects low oil level	Refer to APPENDIX B for replenishing the new oil



3.5.4 Lubricator PLC Control Output Wiring Instruction

Wiring of Lubricator Output signal to the PLC machine.

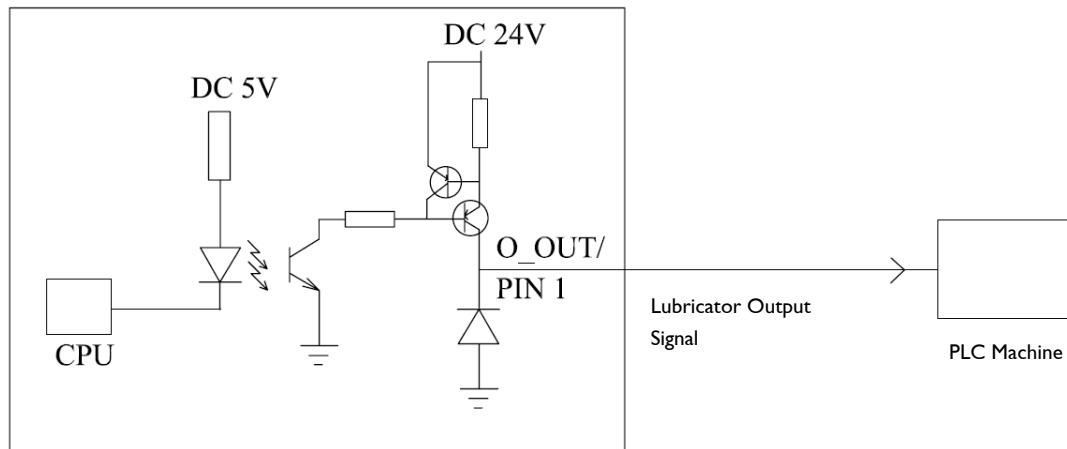

Internal Circuit of Mother Board

Lubricator Output Electrical Specification

Rated Output Voltage : DC 24V
Maximum Output Current : 100mA



4. Hand-Set

A APEX developed the Lubricator Hand-Set controller to perform regular routine grease supply function and real-time feedback to Hand-Set informing user Lubricator current status so no need to go through PLC transfer signal to achieve target.

4.1 Power System Wiring (TIMER Control)

Hand-Set of Lubricator requires DC24V power from PLC machine or independent power source.

 **Caution**



APEX provide the power connector, and the user can use the suitable wire to match the connector bore and application. The current resistance at least 1.5A.

4.1.1 PLC Machine Power Supply

Power supply system Wiring diagram

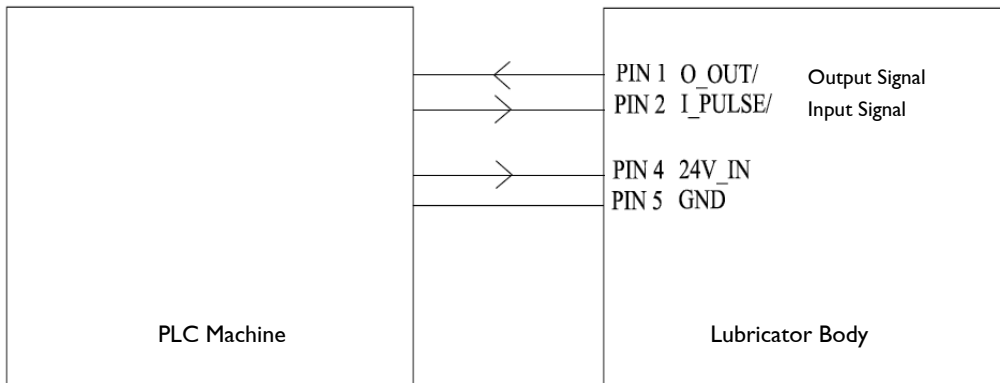

Circuit Protection Switch
(Fuse). Rated Current = 1.1A



4.1.2 Independent Voltage Supply

Lubricator can use PLC machine and also install an independent voltage source for power supply. The independent voltage source can be a power supply device, converting Single-Phase AC 110V / 220V, 50 / 60Hz to DC 24V. During the installation, the input side of power supply should include a circuit protection with no fuse breaker

Power System Wiring diagram

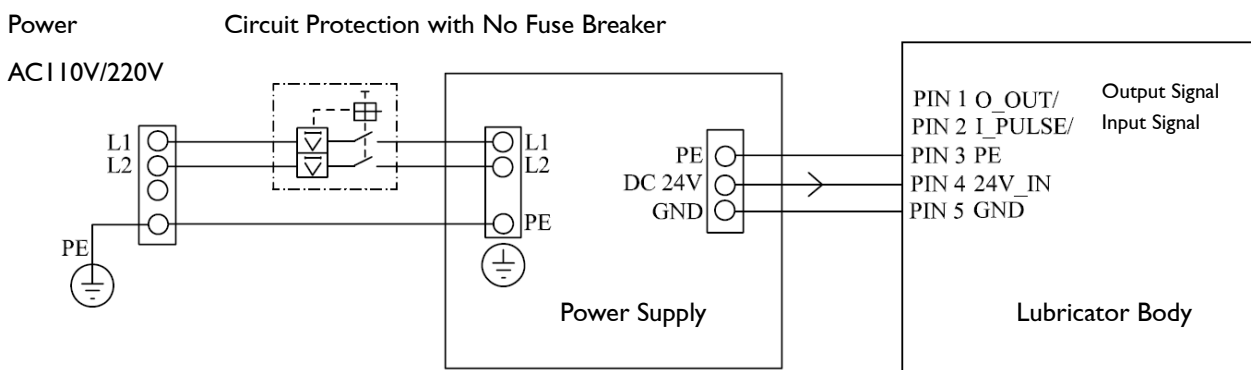

Circuit Protection Switch
(Fuse), Rated Current = 1.1A

 **Warning**



When the input voltage of Lubricator is higher than specified voltage, this will cause damage to the lubricator.



4.2 Instruction of Hand-Set

Lubricator Hand-Set has a friendly interface design, and easy to allow user to quickly install, operate, and set functions according to user needs. A brief overview are as follows:

- Setting of Lubricator timing and oiling frequency
- Both display screen symbol & Key pad are the same
- Self-Monitoring system (While operating, fault / error can be detected anytime to avoid damage the lubricator)
- All parameters stored in EEPROM (No loss of stored data when power is OFF)







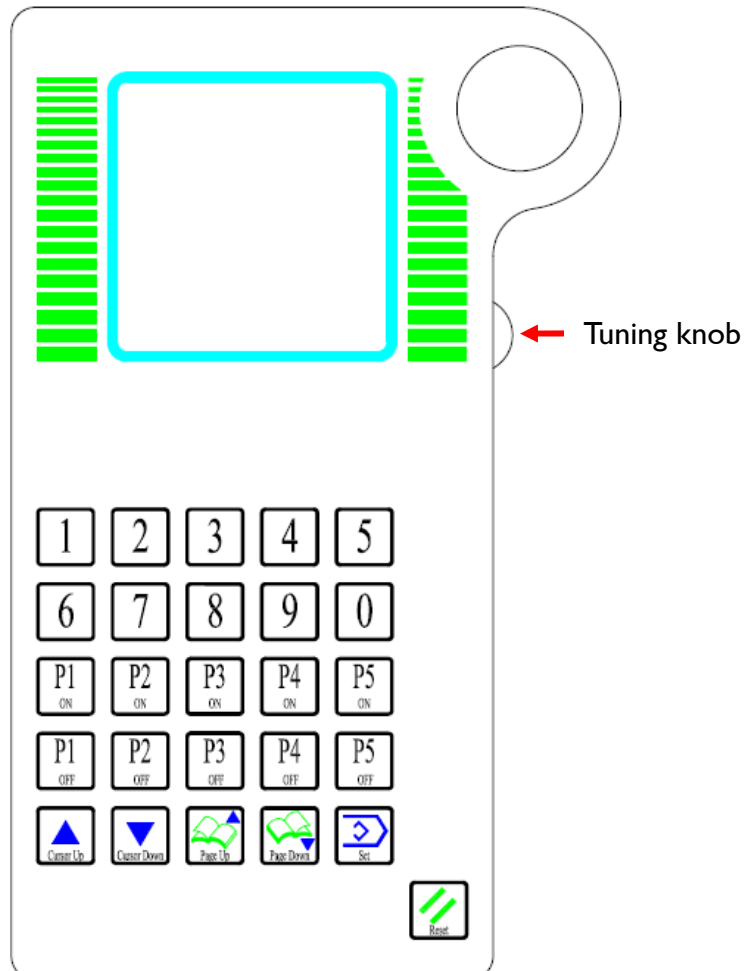





















For Hand-Set setting, APEX defined Pump P1 oil supply outlets as 1.1 and 1.2; Pump P2 oil supply outlets as 2.1 and 2.2; Pump P3 oil supply outlets as 3.1 and 3.2; Pump P4 oil supply outlets as 4.1 and 4.2; Pump P5 oil supply outlets as 5.1 and 5.2

Hand-Set Top View





4.3 Function of Hand-Set

	Numerical Key1		Set
	Numerical Key2		System Reset
	Numerical Key3		Pump 1 continuous dispensing
	Numerical Key4		Pump 2 continuous dispensing
	Numerical Key5		Pump 3 continuous dispensing
	Numerical Key6		Pump 4 continuous dispensing
	Numerical Key7		Pump 5 continuous dispensing
	Numerical Key8		Pump 1 stop dispensing
	Numerical Key9		Pump 2 stop dispensing
	Numerical Key0		Pump 3 stop dispensing
	Cursor Up		Pump 4 stop dispensing
	Cursor Down		Pump 5 stop dispensing
	Page Up	Tuning knob	Adjust the screen brightness
	Page Down		



4.4 Display Screen of Hand-Set

S1	S5	S9
 <p>APEX DYNAMICS, INC. Key in password : * * * * M:1.00 T:1.00 Press \rightarrow to confirm</p>	<p>Power voltage: 24.0 P1 cycle and timer : cycle: 000001 Timer: 0000001 P2 cycle and timer : cycle: 000001 Timer: 0000001</p> <p>\square page up \square page down</p>	<p>Clear motor timer: 0 Operating code use: 0 Operating code: 1234</p> <p>\square page up \square page down</p>
S2	S6	S10
<p>Mode Selection : 0 0 : PLC 1 : TIMER 2 : PLC P1 cycle : 000 days 00 hours 00 minutes P1 motion : 01 times P2 cycle : 000 days 00 hours 00 minutes P2 motion : 01 times</p> <p>\square page up \square page down</p>	<p>P3 cycle and timer : cycle: 000001 Timer: 0000001 P4 cycle and timer : cycle: 000001 Timer: 0000001</p> <p>\square page up \square page down</p>	<p>Error message 1-5</p> <p>\square page up \square page down</p>
S3	S7	S11
<p>P3cycle : 000 days 00 hours 00 minutes P3 motion : 01 times P4 cycle : 000 days 00 hours 00 minutes P4 motion : 01 times</p> <p>\square page up \square page down</p>	<p>P5 cycle and timer : cycle: 000001 Timer: 0000001</p> <p>\square page up \square page down</p>	<p>Error message 6-10</p> <p>\square page up \square page down</p>
S4	S8	S12
<p>P5cycle : 000 days 00 hours 00 minutes P5 motion : 01 times</p> <p>\square page up \square page down</p>	<p>Language Display(語 文版本) : 0 0:English (英文) 1:Chinese (中文)</p> <p>\square page up \square page down</p>	<p>Output signal mode: 0 Clear memory : 0 Error detective : 0 Error counter : 01 Operating mode : 00</p> <p>\square page up \square page down</p>



S13	S17	S21
<p>P1 ADC parameter: 00 P2 ADC parameter: 00 P3 ADC parameter: 00 P4 ADC parameter: 00 P5 ADC parameter: 00</p> <p>Unauthorized setting prohibition</p>	<p>Power voltage: 24.0 P1 cycle and timer : cycle: 000001 Timer: 0000001 P2 cycle and timer : cycle: 000001 Timer: 0000001</p> <p>2.2 operating</p> <p><input type="checkbox"/> page up <input type="checkbox"/> page down</p>	<p>P3 cycle and timer : cycle: 000001 Timer: 0000001 P4 cycle and timer : cycle: 000001 Timer: 0000001</p> <p>4.2 operating</p> <p><input type="checkbox"/> page up <input type="checkbox"/> page down</p>
S14	S18	S22
<p>Power voltage: 24.0 P1 cycle and timer : cycle: 000001 Timer: 0000001 P2 cycle and timer : cycle: 000001 Timer: 0000001</p> <p>1.1 operating</p> <p><input type="checkbox"/> page up <input type="checkbox"/> page down</p>	<p>P3 cycle and timer : cycle: 000001 Timer: 0000001 P4 cycle and timer : cycle: 000001 Timer: 0000001</p> <p>3.1 operating</p> <p><input type="checkbox"/> page up <input type="checkbox"/> page down</p>	<p>P5 cycle and timer : cycle: 000001 Timer: 0000001</p> <p>5.1 operating</p> <p><input type="checkbox"/> page up <input type="checkbox"/> page down</p>
S15	S19	S23
<p>Power voltage: 24.0 P1 cycle and timer : cycle: 000001 Timer: 0000001 P2 cycle and timer : cycle: 000001 Timer: 0000001</p> <p>1.2 operating</p> <p><input type="checkbox"/> page up <input type="checkbox"/> page down</p>	<p>P3 cycle and timer : cycle: 000001 Timer: 0000001 P4 cycle and timer : cycle: 000001 Timer: 0000001</p> <p>3.2 operating</p> <p><input type="checkbox"/> page up <input type="checkbox"/> page down</p>	<p>P5 cycle and timer : cycle: 000001 Timer: 0000001</p> <p>5.2 operating</p> <p><input type="checkbox"/> page up <input type="checkbox"/> page down</p>
S16	S20	S24
<p>Power voltage: 24.0 P1 cycle and timer : cycle: 000001 Timer: 0000001 P2 cycle and timer : cycle: 000001 Timer: 0000001</p> <p>2.1 operating</p> <p><input type="checkbox"/> page up <input type="checkbox"/> page down</p>	<p>P3 cycle and timer : cycle: 000001 Timer: 0000001 P4 cycle and timer : cycle: 000001 Timer: 0000001</p> <p>4.1 operating</p> <p><input type="checkbox"/> page up <input type="checkbox"/> page down</p>	<p>Power voltage: 24.0 P1 cycle and timer : cycle: 000001 Timer: 0000001 P2 cycle and timer : cycle: 000001 Timer: 0000001</p> <p>P1 motor idling</p> <p><input type="checkbox"/> page up <input type="checkbox"/> page down</p>



<p style="text-align: center;">S25</p> <p>Power voltage: 24.0 P1 cycle and timer : cycle: 000001 Timer: 0000001 P2 cycle and timer : cycle: 000001 Timer: 0000001</p> <p>P2 motor idling</p> <p><input type="checkbox"/> page up <input type="checkbox"/> page down</p>	<p style="text-align: center;">S29</p> <p>Power voltage: 24.0 P1 cycle and timer : cycle: 000001 Timer: 0000001 P2 cycle and timer : cycle: 000001 Timer: 0000001</p> <p>Motor1 or pipe block</p> <p><input type="checkbox"/> page up <input type="checkbox"/> page down</p>	<p style="text-align: center;">S33</p> <p>P5 cycle and timer : cycle: 000001 Timer: 0000001</p> <p>Motor5 or pipe block</p> <p><input type="checkbox"/> page up <input type="checkbox"/> page down</p>
<p style="text-align: center;">S26</p> <p>P3 cycle and timer : cycle: 000001 Timer: 0000001 P4 cycle and timer : cycle: 000001 Timer: 0000001</p> <p>P3 motor idling</p> <p><input type="checkbox"/> page up <input type="checkbox"/> page down</p>	<p style="text-align: center;">S30</p> <p>Power voltage: 24.0 P1 cycle and timer : cycle: 000001 Timer: 0000001 P2 cycle and timer : cycle: 000001 Timer: 0000001</p> <p>Motor2 or pipe block</p> <p><input type="checkbox"/> page up <input type="checkbox"/> page down</p>	<p style="text-align: center;">S34</p> <p>Power voltage: 24.0 P1 cycle and timer : cycle: 000001 Timer: 0000001 P2 cycle and timer : cycle: 000001 Timer: 0000001</p> <p>Grease exhausted</p> <p><input type="checkbox"/> page up <input type="checkbox"/> page down</p>
<p style="text-align: center;">S27</p> <p>P3 cycle and timer : cycle: 000001 Timer: 0000001 P4 cycle and timer : cycle: 000001 Timer: 0000001</p> <p>P4 motor idling</p> <p><input type="checkbox"/> page up <input type="checkbox"/> page down</p>	<p style="text-align: center;">S31</p> <p>P3 cycle and timer : cycle: 000001 Timer: 0000001 P4 cycle and timer : cycle: 000001 Timer: 0000001</p> <p>Motor3 or pipe block</p> <p><input type="checkbox"/> page up <input type="checkbox"/> page down</p>	<p style="text-align: center;">S35</p> <p>Power voltage: 24.0 P1 cycle and timer : cycle: 000001 Timer: 0000001 P2 cycle and timer : cycle: 000001 Timer: 0000001</p> <p>Memory reading error</p> <p><input type="checkbox"/> page up <input type="checkbox"/> page down</p>
<p style="text-align: center;">S28</p> <p>P5 cycle and timer : cycle: 000001 Timer: 0000001</p> <p>P5 motor idling</p> <p><input type="checkbox"/> page up <input type="checkbox"/> page down</p>	<p style="text-align: center;">S32</p> <p>P3 cycle and timer : cycle: 000001 Timer: 0000001 P4 cycle and timer : cycle: 000001 Timer: 0000001</p> <p>Motor4 or pipe block</p> <p><input type="checkbox"/> page up <input type="checkbox"/> page down</p>	<p style="text-align: center;">S36</p> <p>Power voltage: 24.0 P1 cycle and timer : cycle: 000001 Timer: 0000001 P2 cycle and timer : cycle: 000001 Timer: 0000001</p> <p>Memory writing error</p> <p><input type="checkbox"/> page up <input type="checkbox"/> page down</p>



<p style="text-align: center;">S37</p> <div style="border: 1px solid black; padding: 5px;"> <p>Power voltage: 24.0 P1 cycle and timer : cycle: 000001 Timer: 0000001 P2 cycle and timer : cycle: 000001 Timer: 0000001</p> <p>INVALID COMMAND</p> <p><input type="checkbox"/> page up <input type="checkbox"/> page down</p> </div>		
<p style="text-align: center;">S38</p> <div style="border: 1px solid black; padding: 5px;"> <p>Power voltage: 24.0 P1 cycle and timer : cycle: 000001 Timer: 0000001 P2 cycle and timer : cycle: 000001 Timer: 0000001</p> <p>Use in timer mode</p> <p><input type="checkbox"/> page up <input type="checkbox"/> page down</p> </div>		
<p style="text-align: center;">S39</p> <div style="border: 1px solid black; padding: 5px;"> <p>Mode Selection : 0 0 : PLC 1 : TIMER 2 : : PLC P1 cycle : 000 days 00 hours 00 minutes P1 motion : 01 times P2 cycle : 000 days 00 hours 00 minutes P2 motion : 01 times</p> <p>RANGE 1~99</p> <p><input type="checkbox"/> page up <input type="checkbox"/> page down</p> </div>		
<p style="text-align: center;">S40</p> <div style="border: 1px solid black; padding: 5px;"> <p>Mode Selection : 0 0 : PLC 1 : TIMER 2 : : PLC P1 cycle : 000 days 00 hours 00 minutes P1 motion : 01 times P2 cycle : 000 days 00 hours 00 minutes P2 motion : 01 times</p> <p>Lubricator stop</p> <p><input type="checkbox"/> page up <input type="checkbox"/> page down</p> </div>		



4.5 Procedure of Set-Up

S1



Press Set

S2

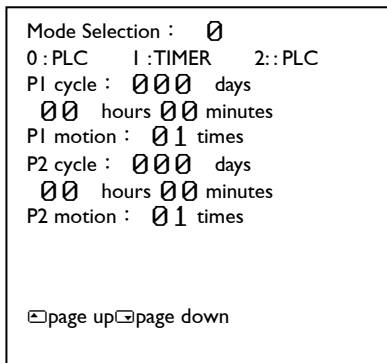

Press Page down

S3

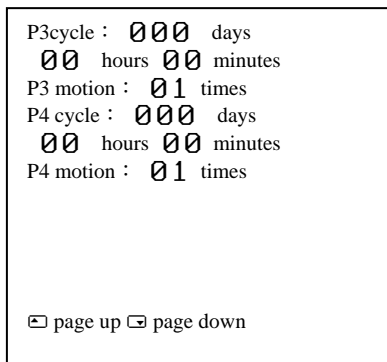

Press Page down

S1 screen will display on Hand-Set when connected to power of lubricator, enter password to go to next setting. The default setting of password is 1234.

1. Select Mode: Setting the lubricator control mode, 0 is the PLC mode 0 control. For details, please refer to Chapter 3: 1 is TIMER mode 1 control. detailed description refer to "Section 4.6.1". 2 is PLC mode 2 control, detailed description refer "Section 4.6.2". When setting mode 0 or mode 2, P1, P2 action override and period, the parameter value cannot be set.
2. P1 Cycle :Set P1 Cycle Time to begin supply Oil at Outlet. 1.1 or 1.2
3. P1 Motion :Set P1 motion 1 stroke per outlet dispenses 0.15cm³ after countdown of P1 cycle time.
4. P2 Cycle :Set P2 Cycle Time to begin supply Oil at Outlet. 2.1 or 2.2
5. P2 Motion :Set P2 motion 1 stroke per outlet dispenses 0.15 cm³ after countdown of P2 cycle time.
1. P3 Cycle :Set P3 Cycle Time to begin supply Oil at Outlet. 3.1 or 3.2
2. P3 Motion :Set P3 motion 1 stroke per outlet dispenses 0.15cm³ after countdown of P3cycle time.
3. P4 Cycle :Set P4 Cycle Time to begin supply Oil at Outlet. 4.1 or 4.2
4. P4 Motion :Set P4 motion 1 stroke per outlet dispenses 0.15cm³ after countdown of P4 cycle time.



S4

P5cycle : 000 days
 00 hours 00 minutes
 P5 motion : 01 times

☐ page up ☐ page down



Press Page down

S5

Power voltage: 24.0
 P1 cycle and timer :
 cycle: 000001
 Timer: 0000001
 P2 cycle and timer :
 cycle: 000001
 Timer: 0000001

☐ page up ☐ page down



Press Page down

S6

P3 cycle and timer :
 cycle: 000001
 Timer: 0000001
 P4 cycle and timer :
 cycle: 000001
 Timer: 0000001

☐ page up ☐ page down



Press Page down

S7

P5 cycle and timer :
 cycle: 000001
 Timer: 0000001

☐ page up ☐ page down



Press Page down

1. P5 Cycle : Set P5 Cycle Time to begin supply Oil at Outlet. 5.1 or 5.2

2. P5 Motion : Set P5 motion 1 stroke per outlet dispenses 0.15cm³ after countdown of P5 cycle time.

1. Power Voltage:

Show the input voltage of lubricant. When the display show 24V means the input voltage is 24V currently.

2. P1 cycle :

Record the cumulative cycle time of P1 pump

3. P1 Timer:

Show the countdown of P1 outlet dispense. The unit is minute.

4. P2 cycle :

Record the cumulative cycle time of P2 pump

5. P2 Timer:

Show the countdown of P2 outlet dispense. The unit is minute.

1. P3 cycle :

Record the cumulative cycle time of P3 pump

2. P3 Timer:

Show the countdown of P3 outlet dispense. The unit is minute.

3. P4 cycle :

Record the cumulative cycle time of P4 pump

4. P4 Timer:

Show the countdown of P4 outlet dispense. The unit is minute.

1. P5 cycle :

Record the cumulative cycle time of P5 pump

2. P5 Timer:

Show the countdown of P5 outlet dispense. The unit is minute.



S8

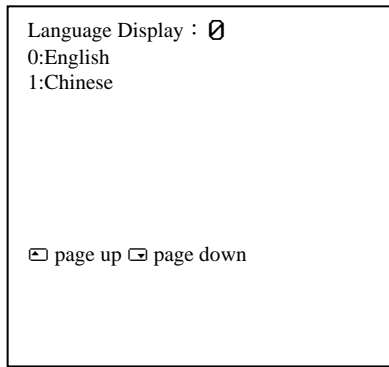

Hand-Set Language display setting key 0 for English or 1 for Chinese then press SET.



Press Page down

S9

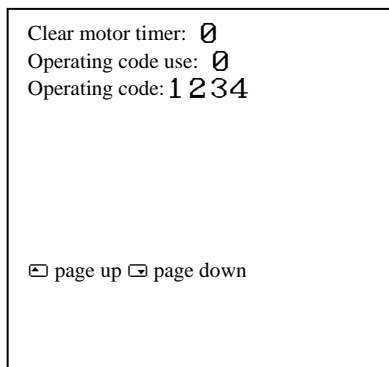

1. Clear motor timer records:

Press Set 1 to clear the total strokes record to 0 times of pump 1, pump 2, pump 3, pump 4 and pump 5.

2. Password setting option:

Press Set 1 to activate and 0 as inactive.

3. Modify the password:

Press Set 1 to modify the password.



Press Page down

S10

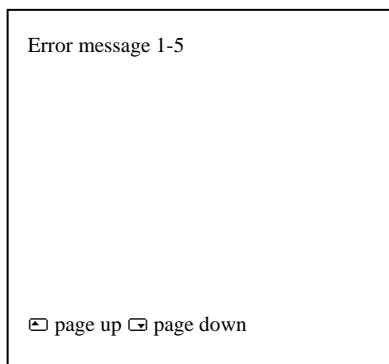

Show the error message history records from Items 1 to 5.



Press Page down

S11

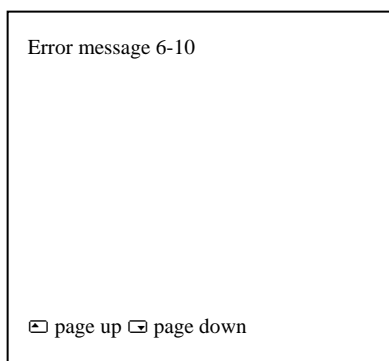

Show the error message history records from Items 6 to 10.



S12

Output signal mode: 0
Clear memory : 0
Error detective : 0
Error counter : 01
Operating mode : 00
☐ page up ☐ page down

Press correct password on S1 display screen will go to S8 setting screen.

Password is 7890.

1. Output signal mode:

Setting up to 0 for PLC mode 0 and PLC mode 2 control: setting up to 1 for TIMER mode 1.

2. Clear Memory:

Press 1 to allow system initialization (Note: all parameters and information will become manufacturer setting) , Press 0 system will not initialize.

3. Error detective:

Press 1 system will monitor motor idling error; Press 0 system will not detect motor idling error.

4. Error counter:

Press the no. of times to set function "motor error detection times". When Motor error reached setting "error detection times", System will display error information. But this function should be used under error detective function is activated.

5. Operating mode:

Press 00 for Standard setting, or for customized demand settings.



4.6 Instruction of System Mode

4.6.1 Instruction of TIMER Mode I

After selecting TIMER Mode, use Hand-Set to set oiling frequency interval and timing. Below are operating examples of each model.

4.6.1.1 Pump I dispensing setting

```

Mode Selection : 1
0:PLC 1:TIMER 2::PLC
PI cycle : 000 days
04 hours 00 minutes
PI motion : 02 times
P2 cycle : 000 days
00 hours 00 minutes
P2 motion : 01 times

page up page down

```



Press Page down

```

Power voltage: 24.0
PI cycle and timer :
cycle: 000000
Timer: 0000240
P2 cycle and timer :
cycle: 000000
Timer: 0000000

page up page down

```



Press Page down

```

Power voltage: 24.0
PI cycle and timer :
cycle: 000000
Timer: 0000232
P2 cycle and timer :
cycle: 000000
Timer: 0000000

page up page down

```

Select I Timer Mode, then set PI cycle time 4hours and PI motion 2 times. This means after 4 hours PI will push 2 strokes at outlet 1.1 and 1.2 alternately with each outlet 1.1 & 1.2 dispensing 0.15 cm³, total oil 0.3cm³

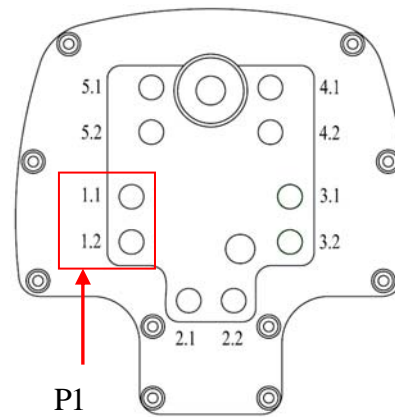

Time elapsed 8 minutes



Power voltage: 24.0
 P1 cycle and timer :
 cycle: 000000
 Timer: 0000240
 P2 cycle and timer :
 cycle: 000000
 Timer: 0000000
 I.1 operating
 ☐page up☐page down

Timer countdown finishes, system restarts countdown again

Pump I begins dispensing oil 0.15 cm³ at outlet I.1



Power voltage: 24.0
 P1 cycle and timer :
 cycle: 000001
 Timer: 0000240
 P2 cycle and timer :
 cycle: 000000
 Timer: 0000000
 I.2 operating
 ☐page up☐page down

P1 cycle records 1 cycle as total no. of stroke

Pump I begins dispensing oil 0.15 cm³ at outlet I.2



Power voltage: 24.0
 P1 cycle and timer :
 cycle: 000002
 Timer: 0000240
 P2 cycle and timer :
 cycle: 000000
 Timer: 0000000
 ☐page up☐page down

P1 cycle records 2 cycles as total no. of stroke with each outlet I.1 & I.2 dispensing 0.15 cm³ total grease 0.3cm³



4.6.1.2 Pump 2 dispensing setting

```

Mode Selection : 1
0 : PLC 1 : TIMER 2 : PLC
P1 cycle : 000 days
00 hours 00 minutes
P1 motion : 01 times
P2 cycle : 000 days
04 hours 00 minutes
P2 motion : 02 times

page up page down

```

↓ Press Page down

```

Power voltage: 24.0
P1 cycle and timer :
cycle: 000000
Timer: 00000000
P2 cycle and timer :
cycle: 000000
Timer: 0000240

page up page down

```

↓

```

Power voltage: 24.0
P1 cycle and timer :
cycle: 000000
Timer: 00000000
P2 cycle and timer :
cycle: 000000
Timer: 0000232

page up page down

```

↓

Select 1 Timer Mode, then set P2 cycle time 4 hours and P2 motion 2 times. This means after 4 hours P2 will push 2 strokes at outlet 2.1 and 2.2 alternately with each outlet 2.1 & 2.2 dispensing 0.15 cm³, total oil 0.3cm³

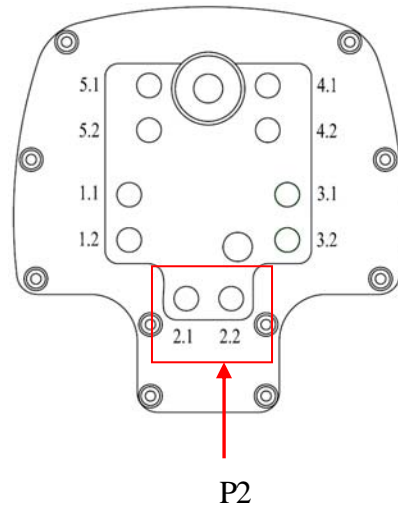

Time elapsed 8 minutes



Power voltage: 24.0
 P1 cycle and timer :
 cycle: 000000
 Timer: 0000000
 P2 cycle and timer :
 cycle: 000000
 Timer: 0000240
 2.1 operating
 ☐page up☐page down

Timer countdown finishes, system restarts countdown again.

Pump 2 begins dispensing oil 0.15 cm³ at outlet 2.1.



Power voltage: 24.0
 P1 cycle and timer :
 cycle: 000000
 Timer: 0000000
 P2 cycle and timer :
 cycle: 000001
 Timer: 0000240
 2.2 operating
 ☐page up☐page down

P2 cycle records 1 cycle as total no. of stroke

Pump 2 begins dispensing oil 0.15 cm³ at outlet 2.2.



Power voltage: 24.0
 P1 cycle and timer :
 cycle: 000000
 Timer: 0000000
 P2 cycle and timer :
 cycle: 000002
 Timer: 0000240
 ☐page up☐page down

P2 cycle records 2 cycles as total no. of stroke with each outlet 2.1 & 2.2 dispensing 0.15 cm³ total grease 0.3cm³



4.6.1.3 Pump 3 dispensing setting

```

Mode Selection : 1
0 : PLC 1 : TIMER 2 : PLC
P1 cycle : 000 days
00 hours 00 minutes
P1 motion : 01 times
P2 cycle : 000 days
00 hours 00 minutes
P2 motion : 01 times
page up page down

```



Press Page down

```

P3cycle : 000 days
04 hours 00 minutes
P3 motion : 02 times
P4 cycle : 000 days
00 hours 00 minutes
P4 motion : 01 times
page up page down

```



Press Page down

```

P3 cycle and timer :
cycle: 000000
Timer: 0000240
P4 cycle and timer :
cycle: 000000
Timer: 0000000
page up page down

```



```

P3 cycle and timer :
cycle: 000000
Timer: 0000232
P4 cycle and timer :
cycle: 000000
Timer: 0000000
page up page down

```

Select I Timer Mode, then set P3cycle time 4hours and P3 motion 2 times. This means after 4 hours P3 will push 2 strokes at outlet 3.1 and 3.2 alternately with each outlet 3.1 & 3.2 dispensing 0.15 cm³, total oil 0.3cm³

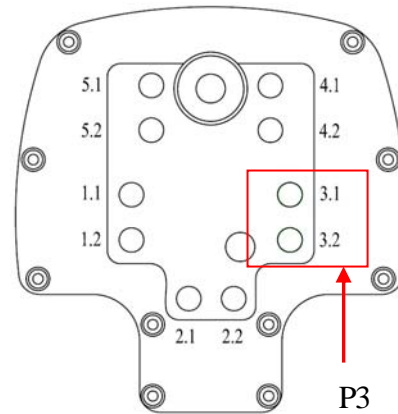

Time elapsed 8 minutes



P3 cycle and timer :
cycle: 000000
Timer: 0000240
P4 cycle and timer :
cycle: 000000
Timer: 0000000
3.1 operating
page up page down

Timer countdown finishes, system restarts countdown again.

Pump 3 begins dispensing oil 0.15 cm³ at outlet 3.1.



P3 cycle and timer :
cycle: 000001
Timer: 0000240
P4 cycle and timer :
cycle: 000000
Timer: 0000000
3.2 operating
page up page down

P3 cycle records 1 cycle as total no. of stroke

Pump 3 begins dispensing oil 0.15 cm³ at outlet 3.2.



P3 cycle and timer :
cycle: 000002
Timer: 0000240
P4 cycle and timer :
cycle: 000000
Timer: 0000000
page up page down

P3 cycle records 2 cycles as total no. of stroke with each outlet 3.1 & 3.2 dispensing 0.15 cm³ total oil 0.3cm³



4.6.1.4 Pump 4 dispensing setting

Mode Selection : 1
 0 :PLC 1 :TIMER 2::PLC
 P1 cycle : 000 days
 00 hours 00 minutes
 P1 motion : 01 times
 P2 cycle : 000 days
 00 hours 00 minutes
 P2 motion : 01 times

page up page down



Press Page down

P3cycle : 000 days
 00 hours 00 minutes
 P3 motion : 01 times
 P4 cycle : 000 days
 04 hours 00 minutes
 P4 motion : 02 times

page up page down



Press Page down

P3 cycle and timer :
 cycle: 000000
 Timer: 0000000
 P4 cycle and timer :
 cycle: 000000
 Timer: 0000240

page up page down



P3 cycle and timer :
 cycle: 000000
 Timer: 0000000
 P4 cycle and timer :
 cycle: 000000
 Timer: 0000232

page up page down

Select I Timer Mode, then set P4cycle time 4hours and P4 motion 2 times. This means after 4 hours P4 will push 2 strokes at outlet 4.1 and 4.2 alternately with each outlet 4.1 & 4.2 dispensing 0.15 cm³, total oil 0.3cm³

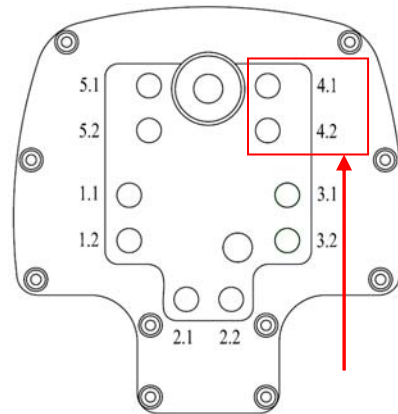

Time elapsed 8 minutes



```

P3 cycle and timer :
cycle: 000000
Timer: 0000000
P4 cycle and timer :
cycle: 000000
Timer: 0000240
4.1 operating
page up page down

```

Timer countdown finishes, system restarts countdown again.

Pump 4 begins dispensing oil 0.15 cm³ at outlet 4.1.



```

P3 cycle and timer :
cycle: 000000
Timer: 0000000
P4 cycle and timer :
cycle: 000001
Timer: 0000240
4.2 operating
page up page down

```

P4 cycle records 1 cycle as total no. of stroke

Pump 4 begins dispensing oil 0.15 cm³ at outlet 4.2.



```

P3 cycle and timer :
cycle: 000000
Timer: 0000000
P4 cycle and timer :
cycle: 000002
Timer: 0000240
page up page down

```

P4 cycle records 2 cycles as total no. of stroke with each outlet 4.1 & 4.2 dispensing 0.15 cm³ total oil 0.3cm³



4.6.1.5 Pump 5 dispensing setting

```

Mode Selection : 1
0 : PLC 1 : TIMER 2 : PLC
P1 cycle : 000 days
00 hours 00 minutes
P1 motion : 01 times
P2 cycle : 000 days
00 hours 00 minutes
P2 motion : 01 times
page up page down

```



Press Page down

```

P5 cycle : 000 days
04 hours 00 minutes
P5 motion : 02 times
page up page down

```



Press Page down

```

P5 cycle and timer :
cycle: 000000
Timer: 0000240
page up page down

```



```

P5 cycle and timer :
cycle: 000000
Timer: 0000232
page up page down

```

Select I Timer Mode, then set P5cycle time 4hours and P5 motion 2 times. This means after 4 hours P5 will push 2 strokes at outlet 5.1 and 5.2 alternately with each outlet 5.1 & 5.2 dispensing 0.15 cm³, total oil 0.3cm³

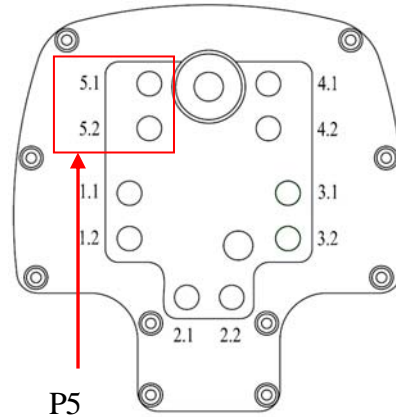

Time elapsed 8 minutes

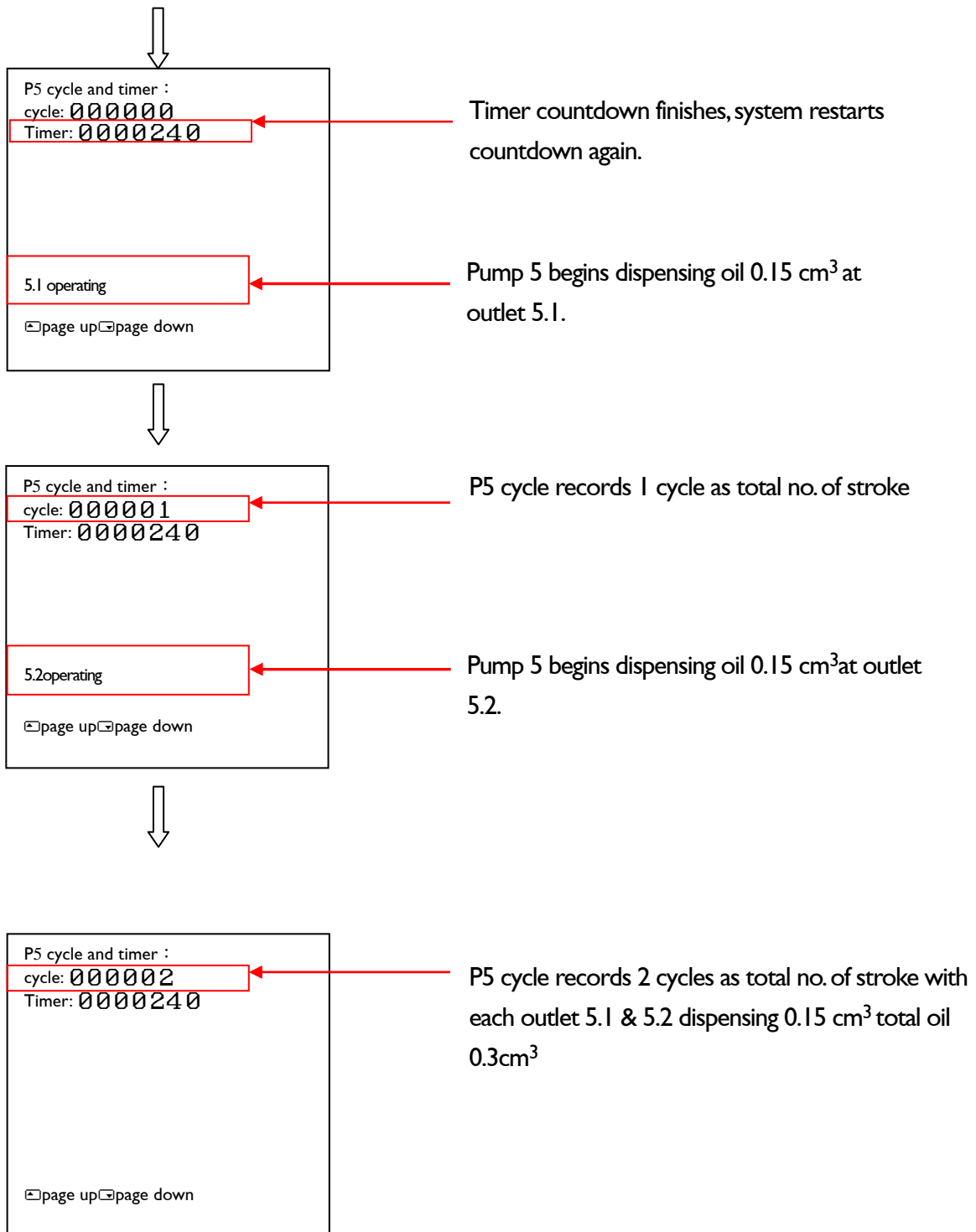



4.6.2 Instruction of PLC Mode 2

The main purpose of PLC mode 2 control is to set up and input the duration time of the 24V signal which from PIN2 pin of lubricator power connector, and then can be control each oil outlet for oil dispense, and following the changed by output signal, notify PLC machine current situation of the lubricator, request to set up mode 2 if you need to use it, the following is the PLC mode 2 control schematic.

4.6.2.1 Model LUG-2102

PLC control diagram:

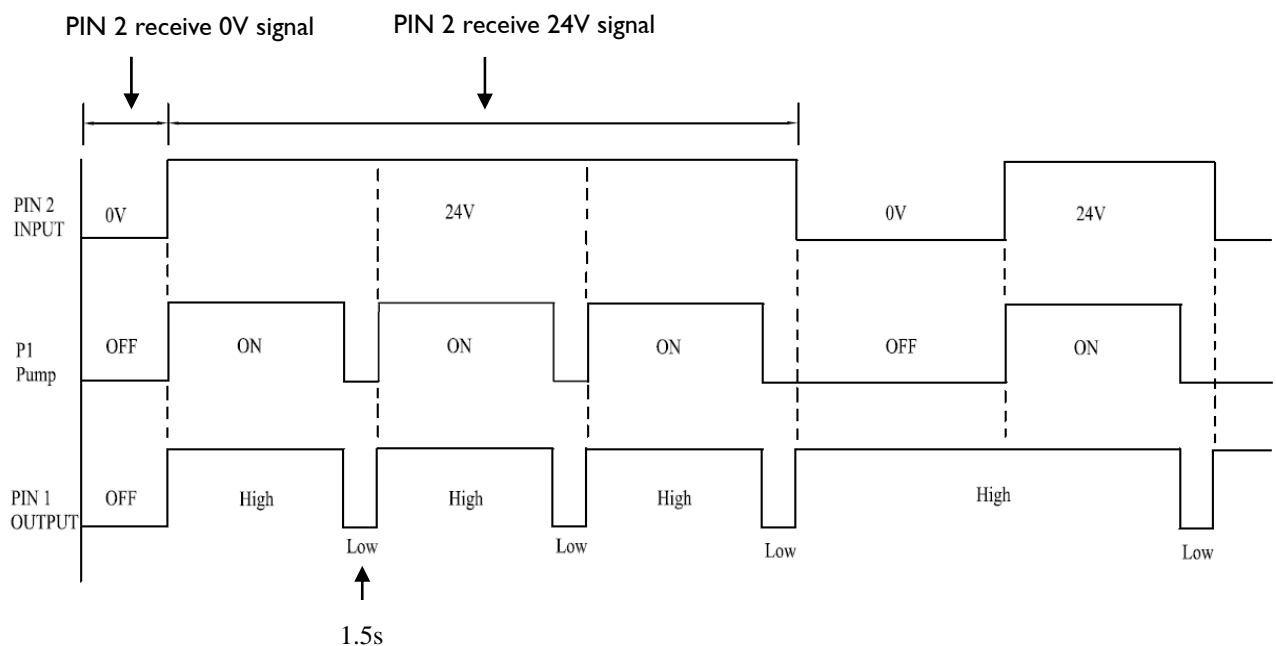

- (1) Lubricator power ON, pump P1 outlet to dispense oil continuously when the PIN 2 receiving 24V signal. One stroke per outlet will dispense oil 0.15cm^3 .
- (2) When the pump P1 complete the dispensing 1 time, PIN 1 output signal changed from HIGH to LOW, the signal duration is 1.5s. This function is applied to inform PLC that the Lubricator has been accomplished dispensed 1 cycle time.
- (3) When PIN 2 receiving the signal from 24V to 0V, pump 1 will stop dispensing. Meanwhile, PIN 1 output HIGH signal continuously.

It is known from the PLC mode 2 control diagram that the P1 oil outlet has the same oil dispensing time. Therefore, it is only requested to set the duration of the signal input to the PIN2 pin 24V to control the oil discharge times of the P1 oil outlet. The time taken for each dispensing of the outlet is 22S.



The signal waveform on PIN1 when oil exhausting:

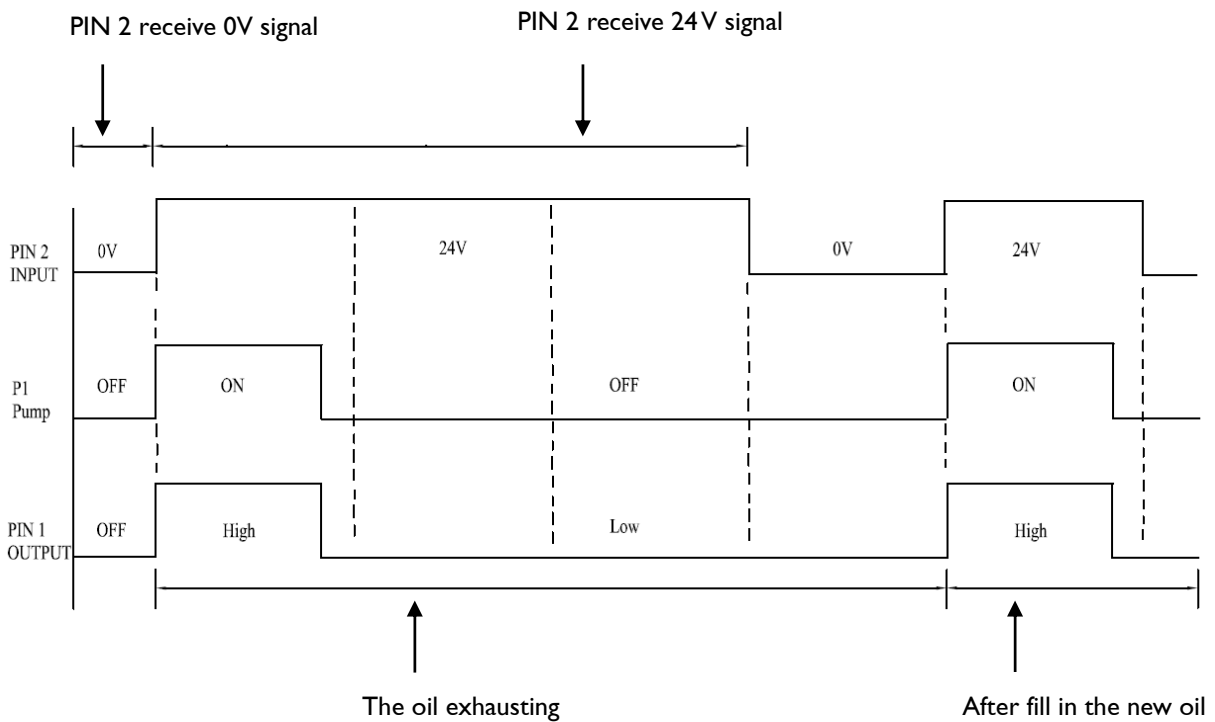

- (1) When lubricator detect the exhausting oil, it will hold and after for the outlet of the P1 dispensing for complete once. PIN 1 will output the signal from HIGH to LOW which inform the user to replenish the oil. During this duration, the pump I can not be dispensed.
- (2) After replenish the oil into lubricator, PIN 1 will output the signal from LOW to HIGH, the pump I can restart to dispense the oil.



The signal waveform on PIN 1 when lubricator can not dispense (The tube is block)

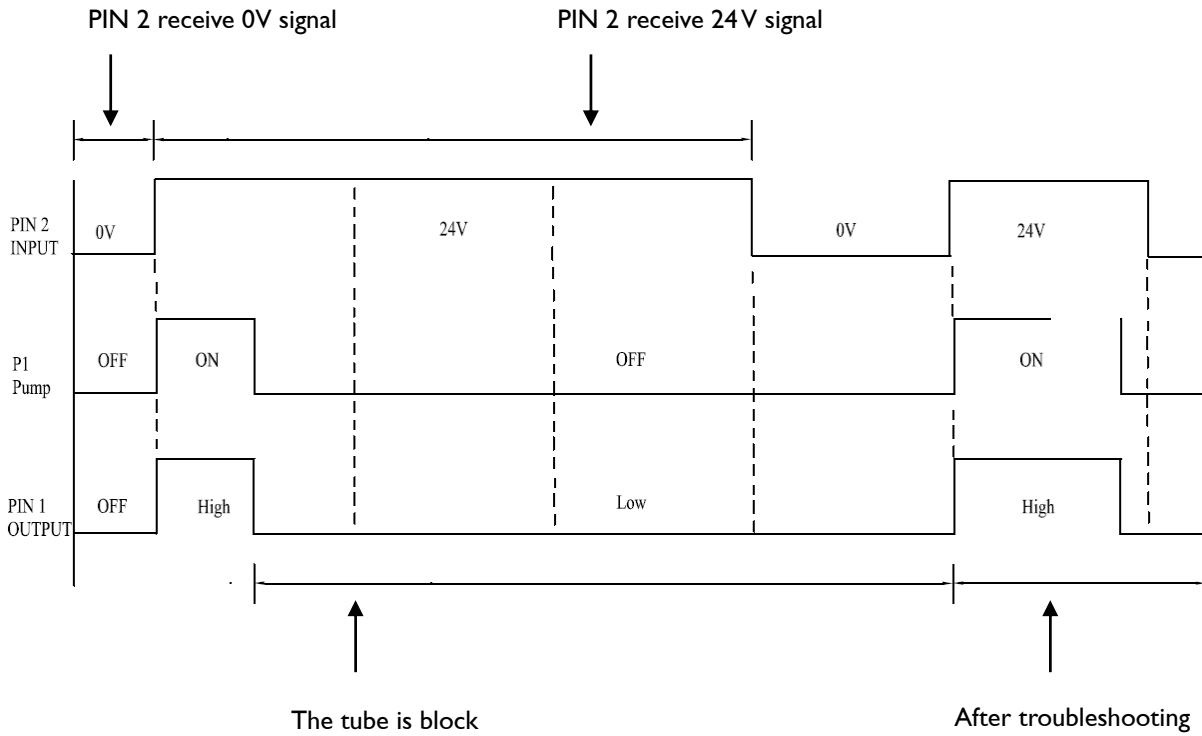

- (1) When lubricator detect the malfunction (ex: the tube is block), PIN 1 will change the signal from HIGH to LOW, and stop dispense the oil.
- (2) After troubleshooting, PIN 1 will change the signal from LOW to HIGH and restart to dispense the oil. The troubleshooting instruction please refer to page 73.



4.6.2.2 Model LUG-2204

PLC control diagram:

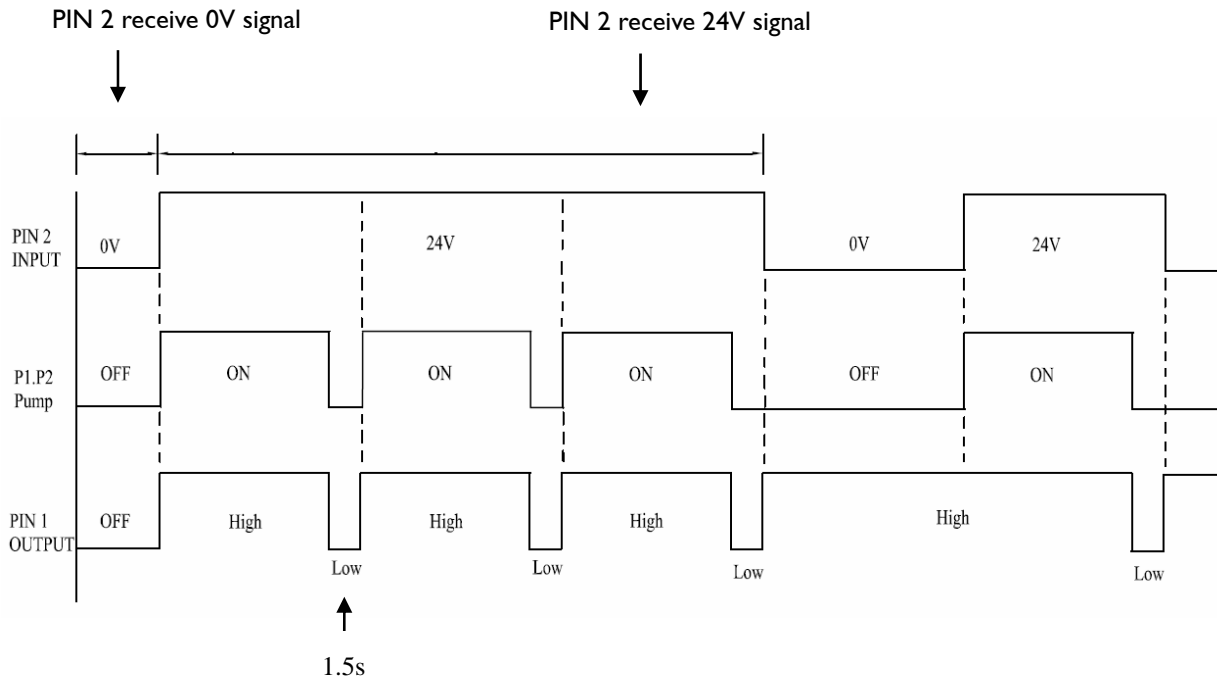

- (1) Lubricator power ON, pump P1 and P2 outlet to dispense oil continuously when the PIN 2 receiving 24V signal. One stroke per outlet will dispense oil 0.15cm^3
- (2) When the pump P1 and P2 complete the dispensing 1 time, PIN 1 output signal changed from HIGH to LOW, the signal duration is 1.5s. This function is applied to inform PLC that the Lubricator has been accomplished dispensed 1 cycle time.
- (3) When PIN 2 receiving the signal from 24V to 0V, pump P1 and P2 will stop dispensing. Meanwhile, PIN 1 output signal HIGH continuously.

The duration is the same of one stroke per outlet of P1, P2, according to the PLC model 2 control diagram. Hence, we can control the stroke times per outlet for pump P1 and P2 by the duration of 24V signal on PIN 2. The duration of both Pump P1 and P2 are 44s for one stroke.



The signal waveform on PIN1 when oil exhausting:

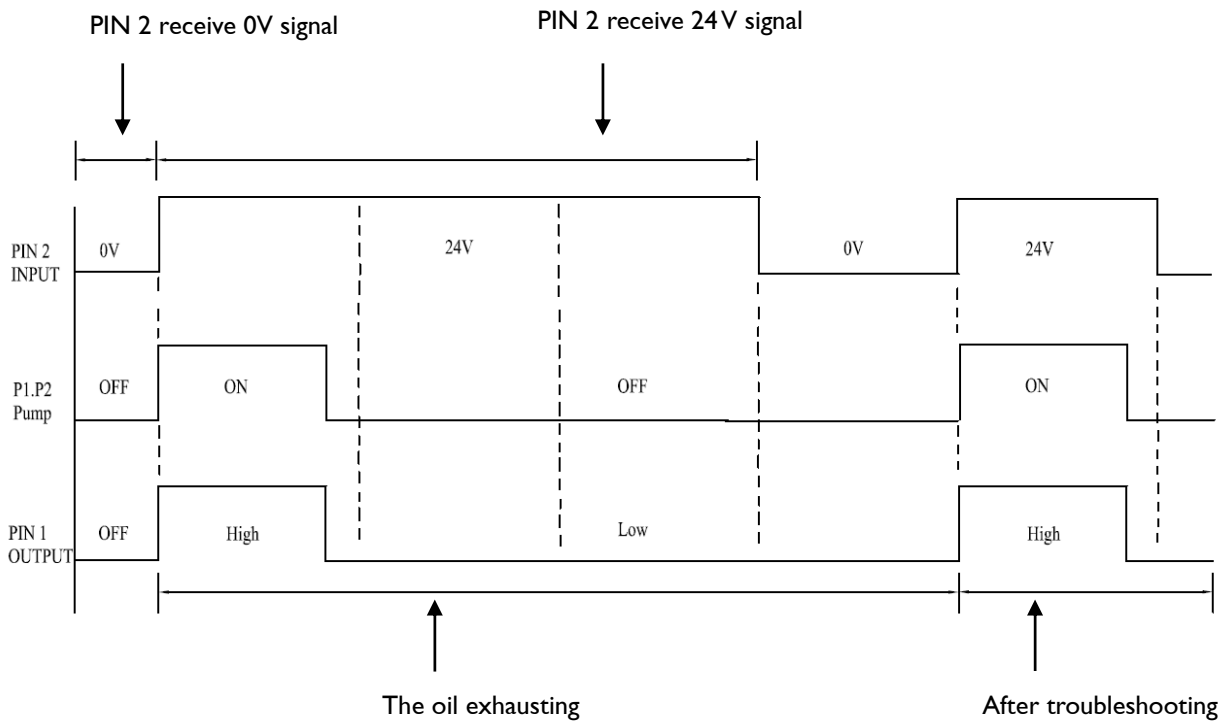

- (1) When lubricator detect the exhausting oil, it will hold and after for the outlet of the P1 and P2 dispensing for complete once. PIN 1 will output the signal from HIGH to LOW which inform the user to replenish the oil. During this duration, the pump P1 and P2 can not be dispensed.
- (2) After replenish the oil into lubricator, PIN 1 will output the signal from LOW to HIGH. Meanwhile, the pump P1 and P2 can restart to dispense the oil.



The signal waveform on PIN 1 when lubricator can not dispense (The tube is block)

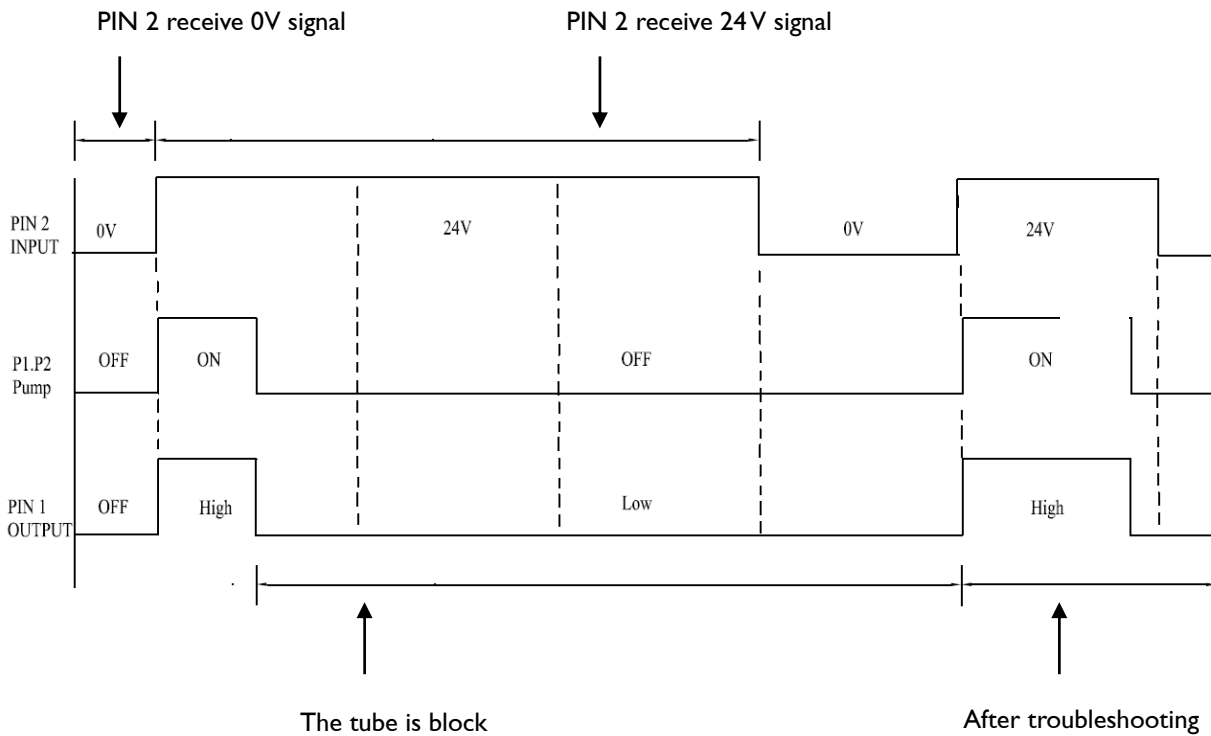

(1) When lubricator detect the malfunction (ex: the tube is block), pump P1 and P2 stop dispense the oil immediately. Meanwhile, PIN 1 will change the signal from HIGH to LOW for inform the malfunction message to user.

(2) After troubleshooting, PIN 1 will change the signal from LOW to HIGH. Meanwhile, pump P1 and P2 restart to dispense the oil. The troubleshooting instruction please refer to page 73.



4.6.2.3 Model LUG-2306

PLC control diagram:

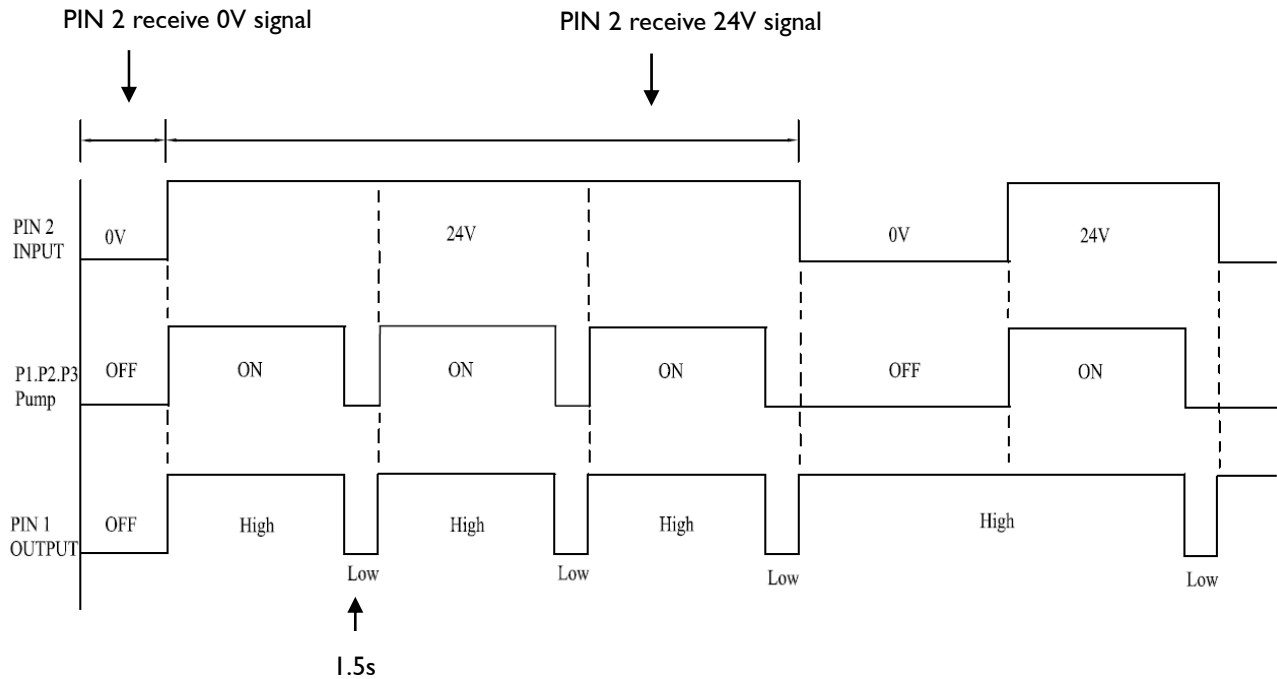

- (1) Lubricator power ON, pump P1, P2 and P3 outlet to dispense oil continuously when the PIN 2 receiving 24V signal. One stroke per outlet will dispense oil 0.15cm^3 .
- (2) When the pump P1, P2 and P3 complete the dispensing 1 time, PIN 1 output signal changed from HIGH to LOW, the signal duration is 1.5s. This function is applied to inform PLC that the Lubricator has been accomplished dispensed 1 cycle time.
- (3) When PIN 2 receiving the signal from 24V to 0V, pump P1, P2 and P3 will stop dispensing simultaneously. Meanwhile, PIN 1 output HIGH signal.

The duration is the same of one stroke per outlet of P1, P2, P3 according to the PLC model 2 control diagram. Hence, we can control the stroke times per outlet for pump P1 and P2 by the duration of 24V signal on PIN 2. The duration of both Pump P1, P2 and P3 are 66s for one stroke.



The signal waveform on PIN1 when oil exhausting:

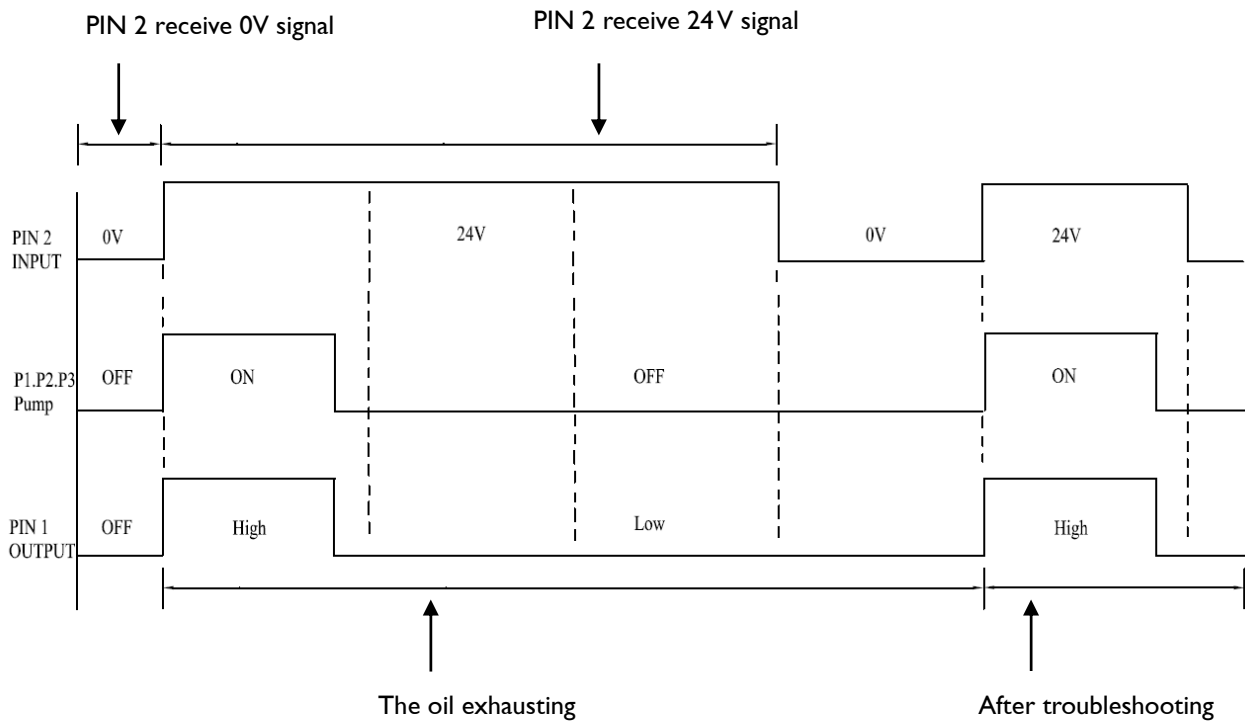

- (1) When lubricator detect the exhausting oil, it will hold and after for the outlet of the P1、P2 and P3 dispensing for complete once. PIN 1 will output the signal from HIGH to LOW which inform the user to replenish the oil. During this duration, the pump P1、P2 and P3 can not be dispensed.
- (2) After replenish the oil into lubricator, PIN 1 will output the signal from LOW to HIGH, the pump P1、P2 and P3 can restart to dispense the oil.



The signal waveform on PIN 1 when lubricator can not dispense (The tube is block)

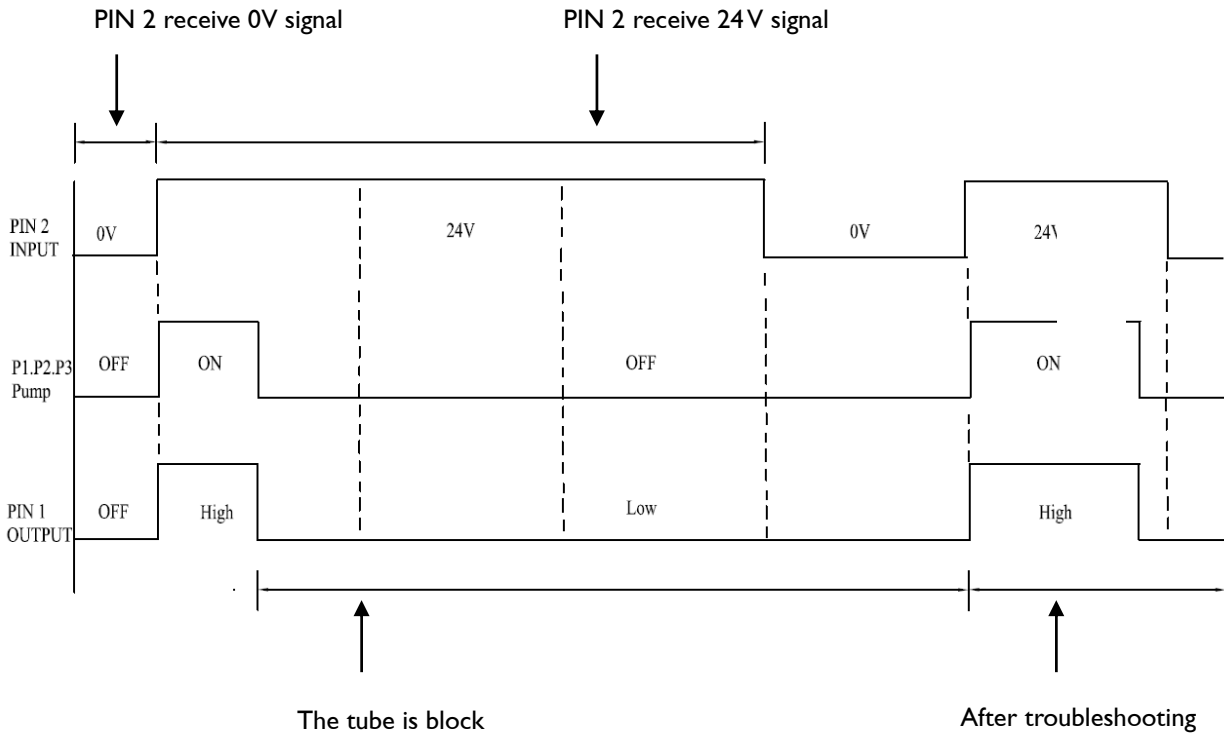

(1) When lubricator detect the malfunction (ex: the tube is block), pump P1, P2 and P3 stop dispense the oil immediately. Meanwhile, PIN 1 will change the signal from HIGH to LOW for inform the malfunction message to user.

(2) After troubleshooting, PIN 1 will change the signal from LOW to HIGH. Simultaneously, pump P1, P2 and P3 restart to dispense the oil. The troubleshooting instruction please refer to page 73.



4.6.2.4 Model LUG-2408

PLC control diagram:

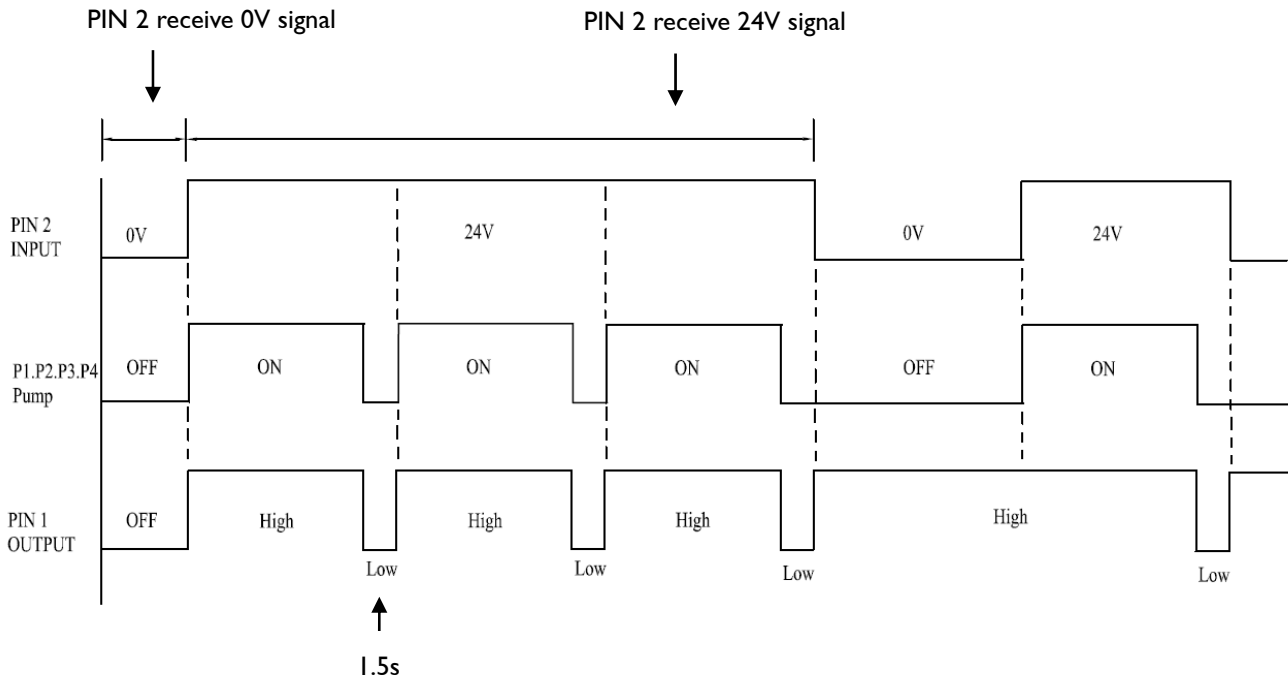

- (1) Lubricator power ON, pump P1, P2, P3 and P4 outlet to dispense oil continuously when the PIN 2 receiving 24V signal. One stroke per outlet will dispense oil 0.15cm^3 individually.
- (2) When the pump P1, P2, P3 and P4 complete the dispensing 1 time, PIN 1 output signal changed from HIGH to LOW, the signal duration is 1.5s. This function is applied to inform PLC that the Lubricator has been accomplished dispensed 1 cycle time.
- (3) When PIN 2 receiving the signal from 24V to 0V, pump P1, P2, P3 and P4 pumps will stop dispensing. Meanwhile, PIN 1 output HIGH signal.

The duration is the same of one stroke per outlet of P1, P2, P3, P4 according to the PLC model 2 control diagram. Hence, we can control the stroke times per outlet for pump P1 and P2 by the duration of 24V signal on PIN 2. The duration of both Pump P1, P2, P3 and P4 are 88s for one stroke.



The signal waveform on PIN1 when oil exhausting:

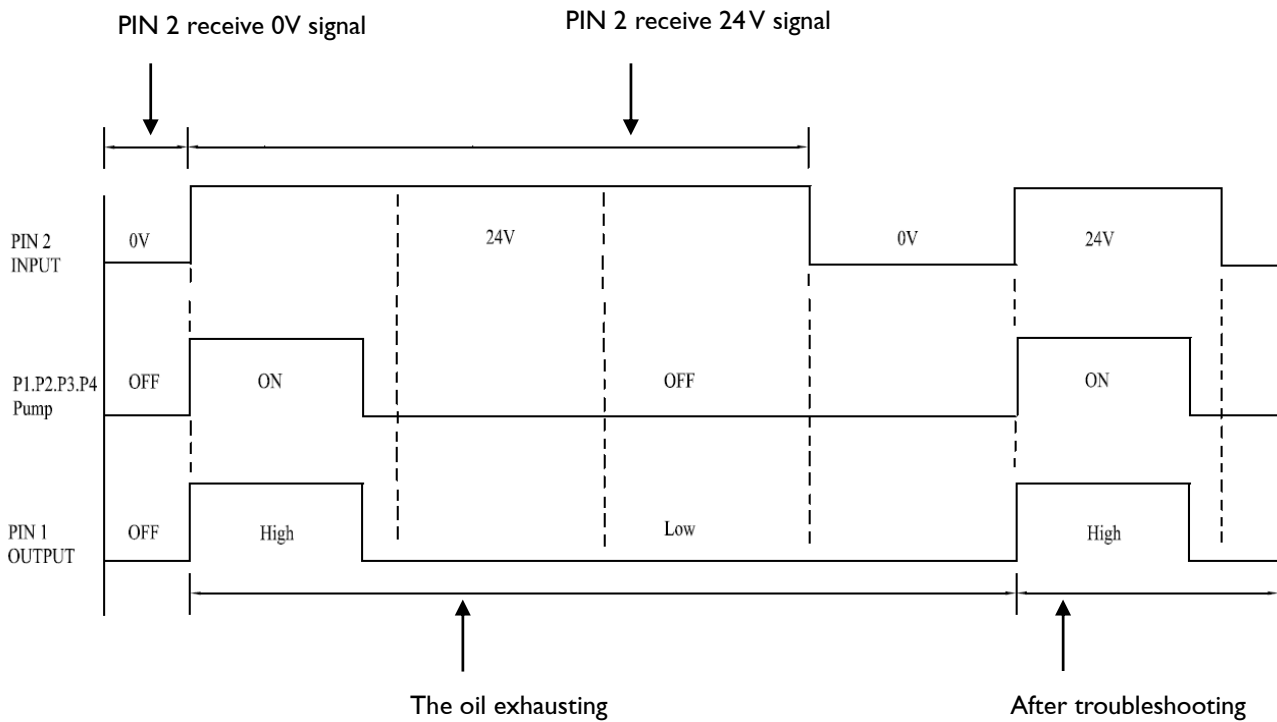

- (1) When lubricator detect the exhausting oil, it will hold and after for the outlet of the P1 、 P2 、 P3 and P4 dispensing for complete once. PIN 1 will output the signal from HIGH to LOW which inform the user to replenish the oil. During this duration, the pump P1 、 P2 、 P3 and P4 can not be dispensed.
- (2) After replenish the lubricant into lubricator, PIN 1 will output the signal from LOW to HIGH. Meanwhile, the pump P1 、 P2 、 P3 and P4 can restart to dispense the oil.



The signal waveform on PIN 1 when lubricator can not dispense (The tube is block)

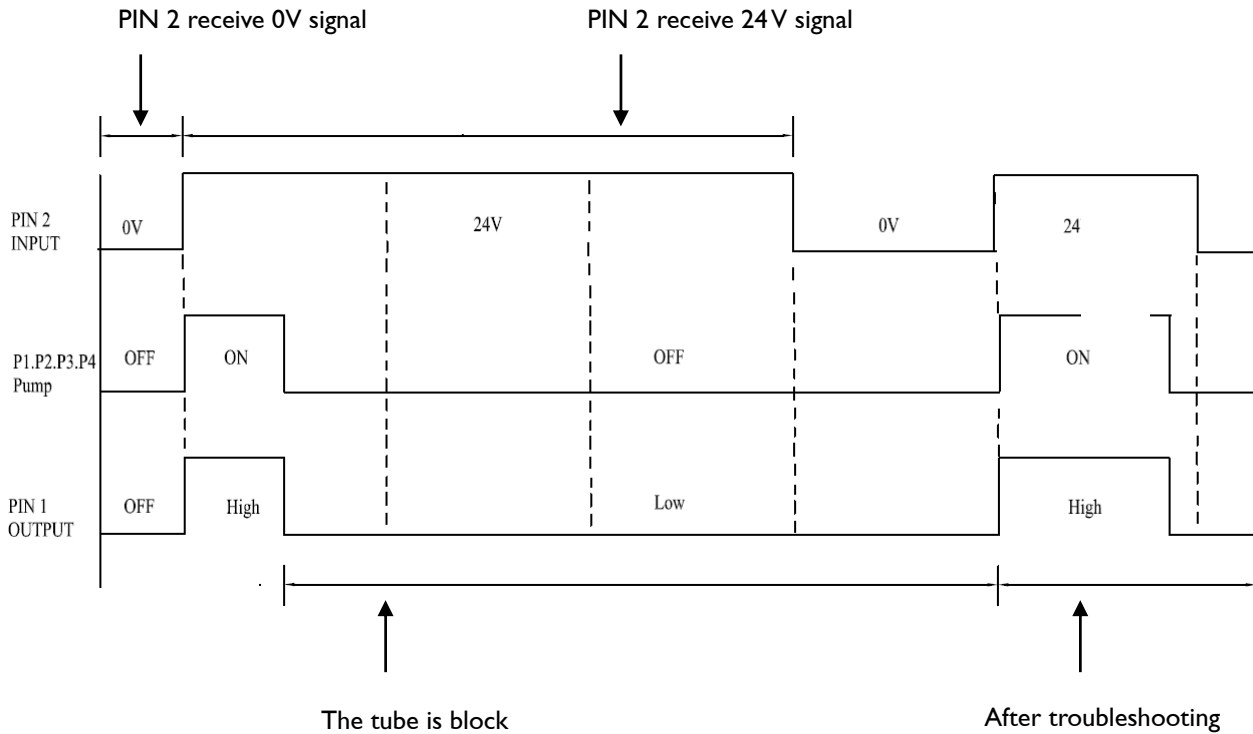

(1) When lubricator detect the malfunction (ex: the tube is block), pump P1, P2, P3 and P4 stop dispense the oil immediately. Meanwhile, PIN 1 will change the signal from HIGH to LOW for inform the malfunction message to user.

(2) After troubleshooting, PIN 1 will change the signal from LOW to HIGH. Simultaneously, pump P1, P2, P3 and P4 restart to dispense the oil. The troubleshooting instruction please refer to page 73.



4.6.2.5 Model LUG-2510

PLC control diagram:

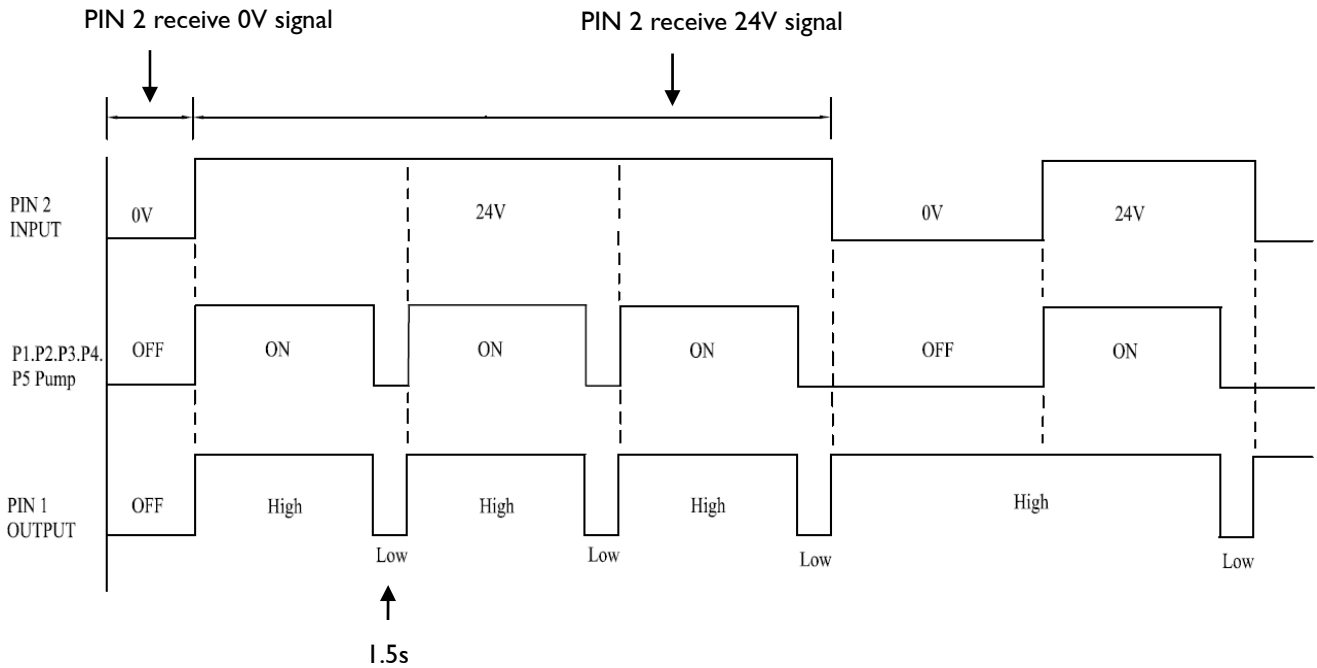

- (1) Lubricator power ON, pump P1, P2, P3, P4 and P5 outlet to dispense oil continuously when the PIN 2 receiving 24V signal. One stroke per outlet will dispense oil 0.15cm^3 individually.
- (2) When the pump P1, P2, P3, P4 and P5 complete the dispensing 1 time, PIN 1 output signal changed from HIGH to LOW, the signal duration is 1.5s. This function is applied to inform PLC that the Lubricator has been accomplished dispensed 1 cycle time.
- (3) When PIN 2 receiving the signal from 24V to 0V, pump P1, P2, P3, P4 and P5 will stop dispensing. Meanwhile, PIN 1 output HIGH signal.

The duration is the same of one stroke per outlet of P1, P2, P3, P4, P5 according to the PLC model 2 control diagram. Hence, we can control the stroke times per outlet for pump P1 and P2 by the duration of 24V signal on PIN 2. The duration of both Pump P1, P2, P3, P4 and P5 are 110s for one stroke.



The signal waveform on PIN1 when oil exhausting:

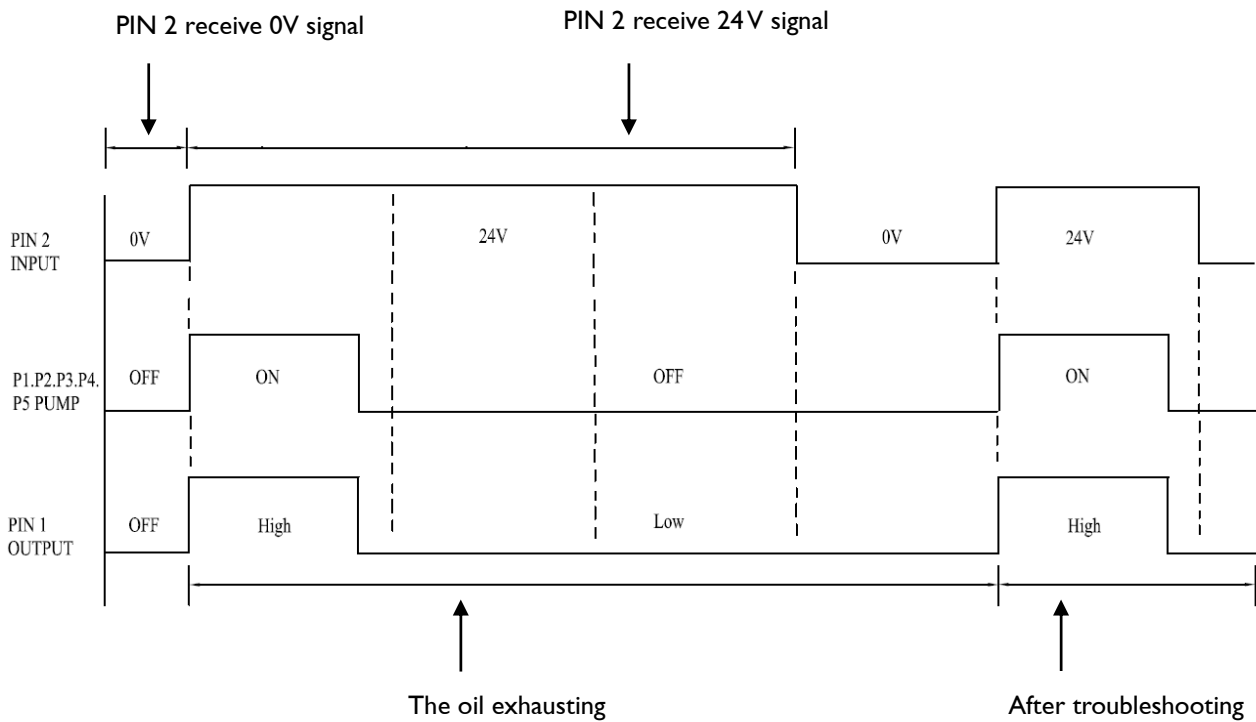

- (1) When lubricator detect the exhausting oil, it will hold and after for the outlet of the P1 、 P2 、 P3 、 P4 and P5 dispensing for complete once. PIN I will output the signal from HIGH to LOW which inform the user to replenish the oil. During this duration, the pump P1 、 P2 、 P3 、 P4 and P5 can not be dispensed.
- (2) After replenish the oil into lubricator, PIN I will output the signal from LOW to HIGH. Meanwhile, the pump P1, P2, P3, P4 and P5 can restart to dispense the oil.



The signal waveform on PIN 1 when lubricator can not dispense (The tube is block)

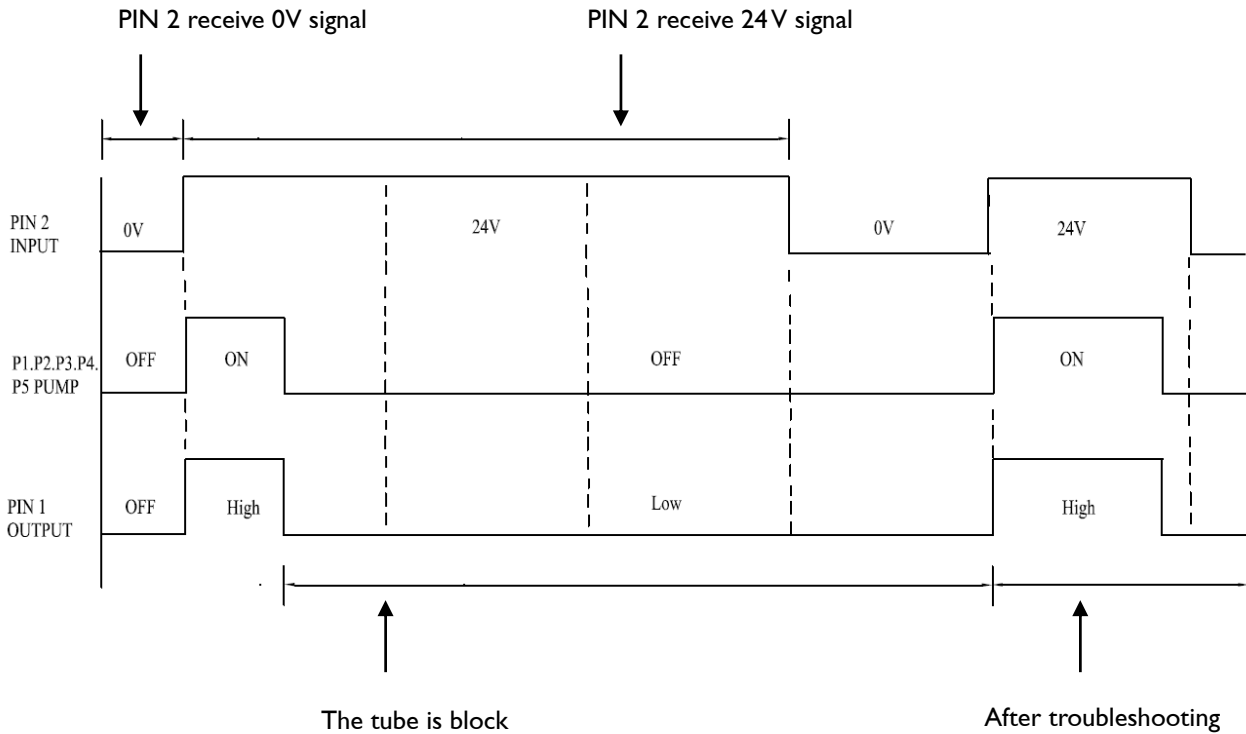

(1) When lubricator detect the malfunction (ex: the tube is block), pump P1, P2, P3, P4 and P5 stop dispense the oil immediately. Meanwhile, PIN 1 will change the signal from HIGH to LOW for inform the malfunction message to user.

(2) After troubleshooting, PIN 1 will change the signal from LOW to HIGH. Simultaneously, pump P1, P2, P3, P4 and P5 restart to dispense the oil. The troubleshooting instruction please refer to page 73.



4.6.3 Clear Motor Timer Setting

(I) Clear Motor Timer

Set I to clear existing motor parameters, the system recorded output P1, P2, P3, P4 and P5 cycles are all erased 0. This function allows users to know lubricator total cycles.

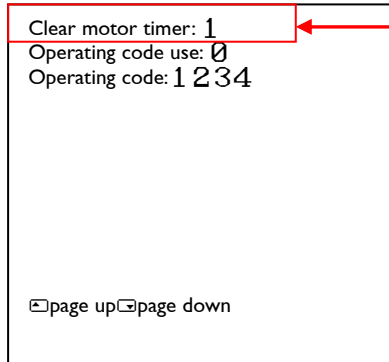

Key "Clear motor timer" as I.

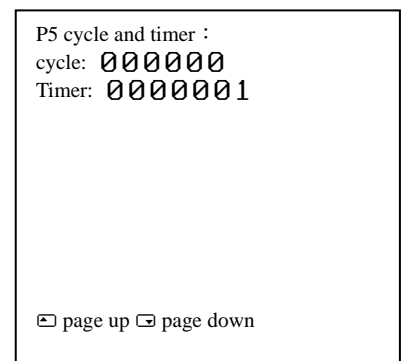
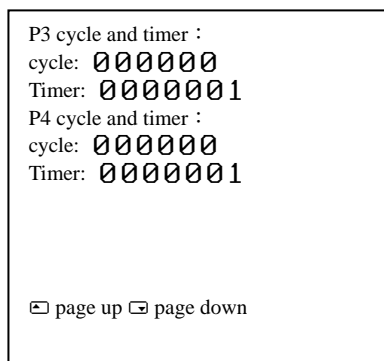
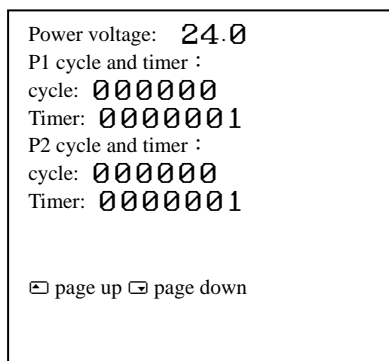
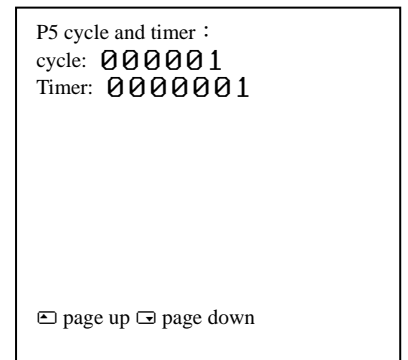
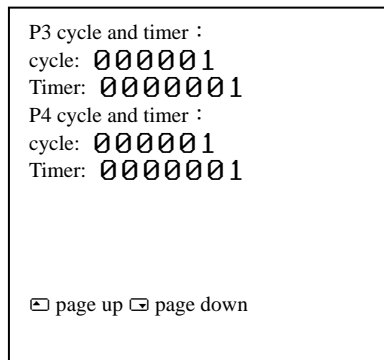
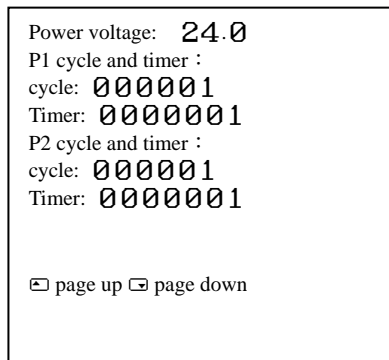
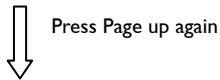



(2) Password Setting

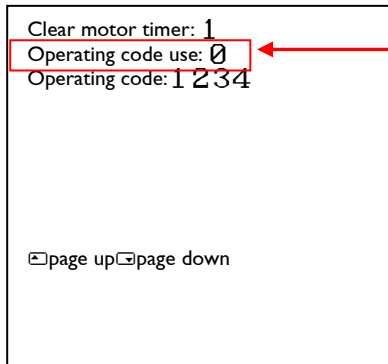

Set "Operating code use" as 0, you can press "SET" on S1 screen and enter into S2 screen without password.

S1



Press Reset



S2

Press Set

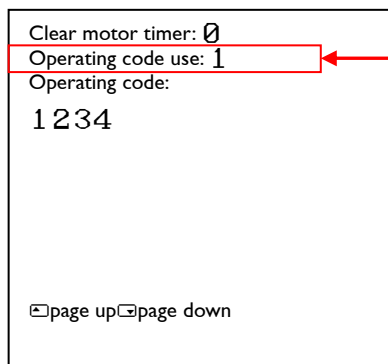
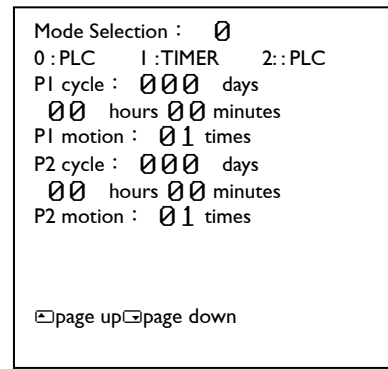

Set "Operating code use" as 1 and Set "Operating Code" as 1234. At this moment, you should key in password "1234" on S1 screen and enter into S2 screen.

S1



Press Reset



S2

Key password 1234,
 and press Set

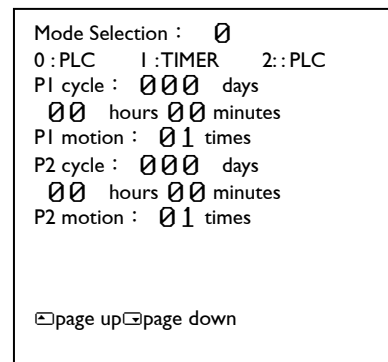



4.6.4 Description of Error Message

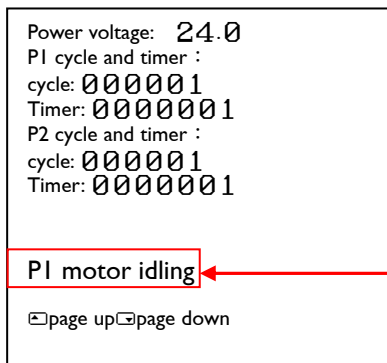

Error message appears on screen for example PI motor idling.

S10

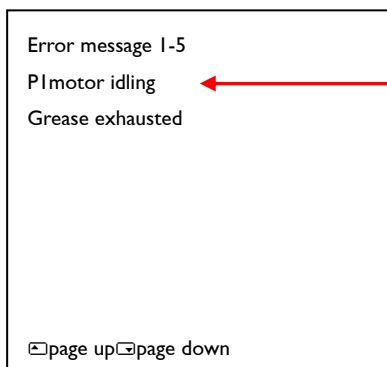

“PI Motor idling” display in system “Error Message Record”, new message is displayed in S10 screen and total 5 error messages and then 6th message will be saved in S11 screen.

S11

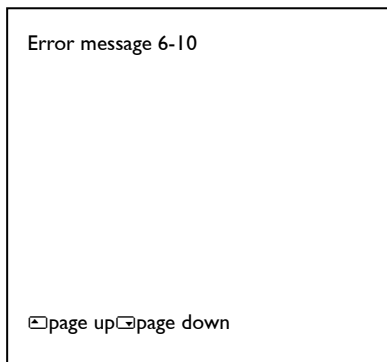



Error message description:

Error message	Description	Troubleshooting
P1 Motor Idle	Lubricator internal P1 motor idling.	Please refer Page 73
P2 Motor Idle	Lubricator internal P2 motor idling.	Please refer Page 73
P3 Motor Idle	Lubricator internal P3 motor idling.	Please refer Page 73
P4 Motor Idle	Lubricator internal P4 motor idling.	Please refer Page 73
P5 Motor Idle	Lubricator internal P5 motor idling.	Please refer Page 73
P1 motor or pipe block	Lubricator internal P1 motor cannot rotate.	Please refer Page 73
P2 motor or pipe block	Lubricator internal P2 motor cannot rotate.	Please refer Page 73
P3 motor or pipe block	Lubricator internal P3 motor cannot rotate.	Please refer Page 73
P4 motor or pipe block	Lubricator internal P4 motor cannot rotate.	Please refer Page 73
P5 motor or pipe block	Lubricator internal P5 motor cannot rotate.	Please refer Page 73
Memory reading error, Memory writing error	1. Input voltage can not reach 24V standard 2. Lubricator PCB board malfunction	1. Check the Input Voltage 24V 2. Contact Manufacturer technician



4.6.5 Description of Output Signal Mode

After installing Lubricator Hand-Set, the lubricator output signal can be changed. The Lubricator can be used in PLC control Mode 0 or Timer Mode 1 or PLC Mode 2. Instructions are as follows:

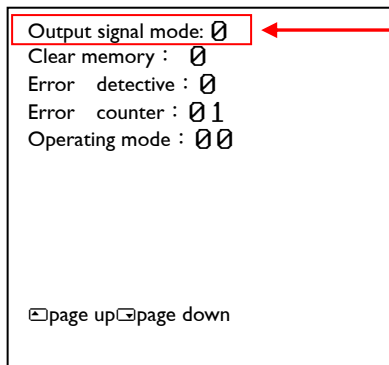

Set "Output Signal Mode" 0 for PLC control Mode 0 and PLC control Mode 2. Refer to Chapter 3.5 for PLC control Mode 0 illustration. And refer 4.6.2 chapter for PLC Mode 2.

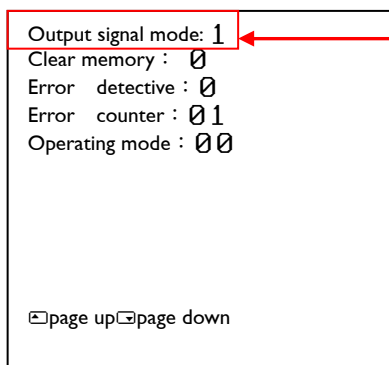

Output Signal Mode, Set 1 as "Timer Mode 1 control" .



Set “Output Signal Mode” as I, control mode as TIMER mode I, power plug PIN I output waveform is display as below. This function is used to install additional alarm device to inform the user that the lubricator is malfunction and require troubleshooting.

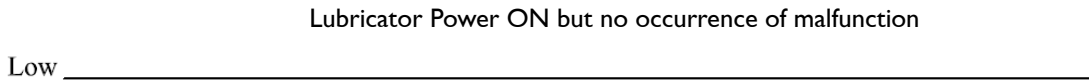
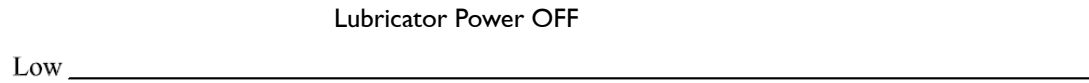

Lubricator power OFF or power ON but no occurrence of malfunction, PIN I output signal are LOW.

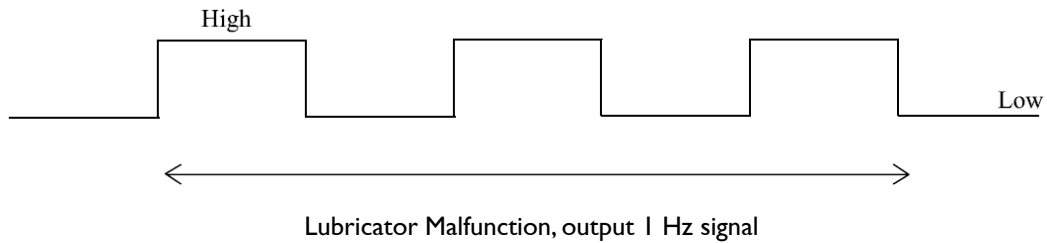

If the Lubricator malfunction, PIN I will continue to output 1Hz signal, at this moment, please refer to below table for Lubricator troubleshooting.

Malfunction	Reason	Remedy
Lubricator cannot dispense oil	PA Tube contain trapped air	Refer to chapter 4.8 for troubleshooting.
	Lubricator internal motor blockage, PA Tube Blockage	Check the foreign particles in PA Tube for blockage or PA Tube length is too long.
	Lubricator internal motor idling	Contact APEX Manufacturer
	Sensor plate reaches exhausting oil level detection zone	Refer APPENDIX B to replenish the new oil



4.6.6 TIMER Mode I Control Output Wiring Instruction

Wiring of Lubricator with alarm device.

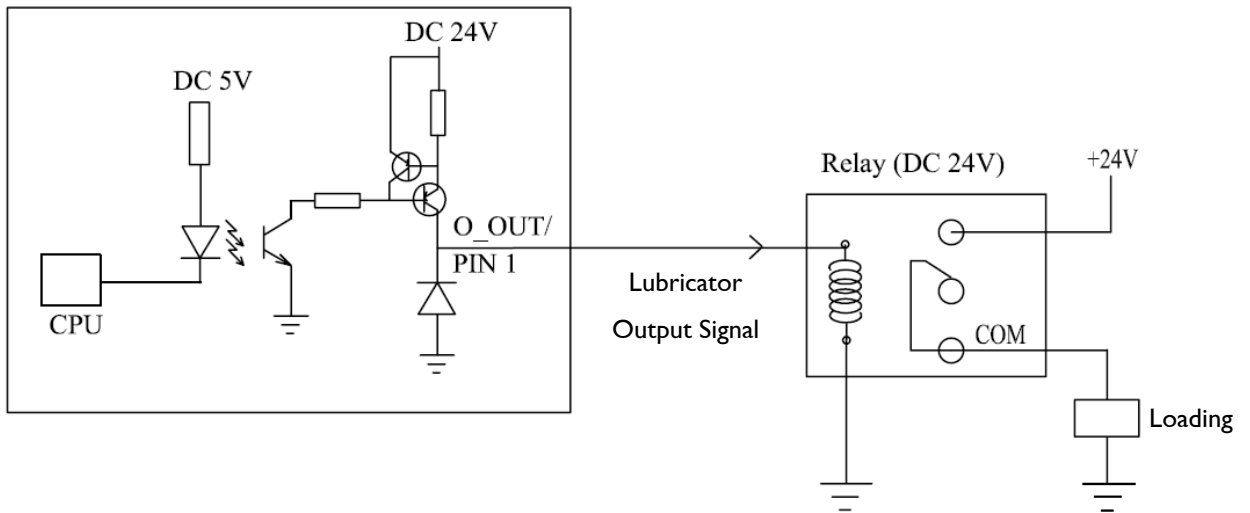

Lubricator Output Electrical Specification

Rated Voltage : DC 24V

Maximum Output Current : 100mA



4.6.7 Clear Memory Illustration

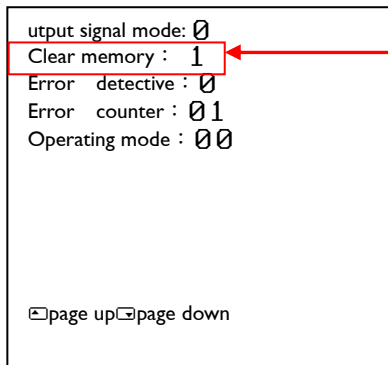

Set "Clear Memory" as 1, system will initialize lubricator parameters returning to its original manufacturer setting as shown below.

Set "Clear Memory" as 1, Hand-Set all parameters return to original manufacturer setting.

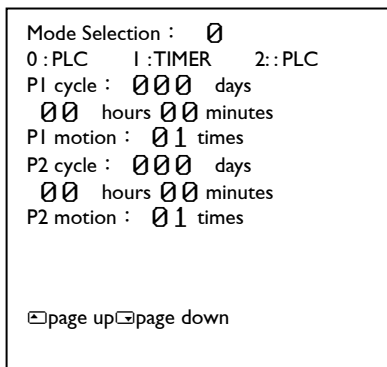

Manufacturer Setting

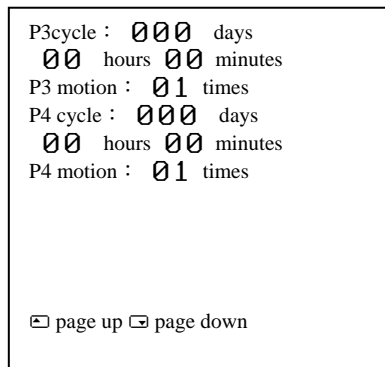

Manufacturer Setting

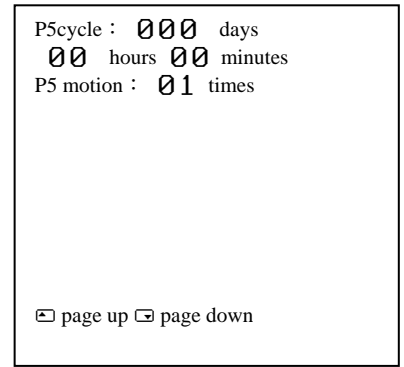

Manufacturer Setting

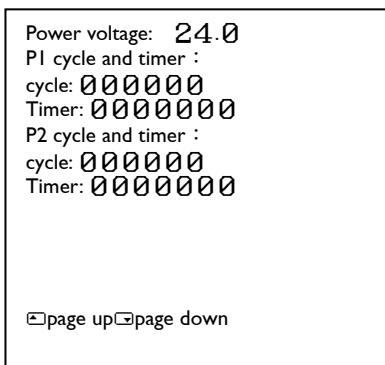

Manufacturer Setting

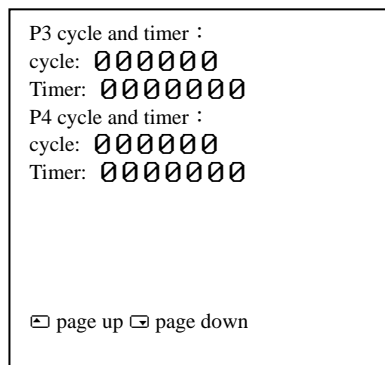

Manufacturer Setting

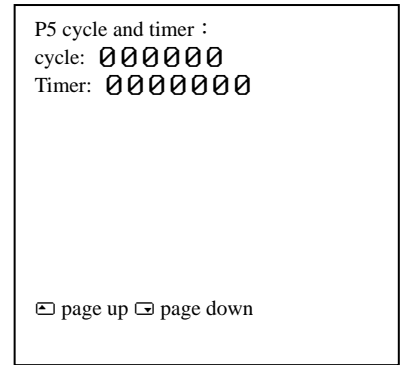

Manufacturer Setting



Language Display(語
文版本) : 0
0:English(英文)
1:Chinese(中文)

☐page up☐page down

Manufacturer Setting

Clear motor timer: 0
Operating code use: 0
Operating code: 1 2 3 4

☐page up☐page down

Manufacturer Setting

Error message 1-5

☐page up☐page down

Manufacturer Setting

Error message 6-10

☐page up☐page down

Manufacturer Setting

Output signal mode: 0
Clear memory : 0
Error detective : 0
Error counter : 6
Operating mode : 0 0

☐ page up ☐ page down

Manufacturer Setting



4.6.8 Motor Error Detective and Error Counter

When Lubricator is unable to dispense oil, this may internal motor gear is loosened that making motor idling thus causing lubricator to fail to deliver oil. However, this function can be used to check this malfunction.

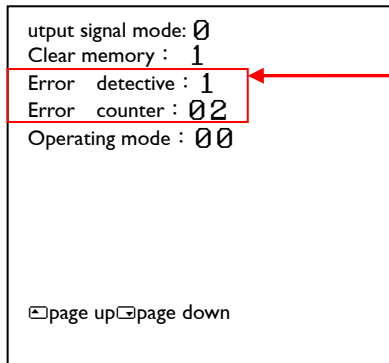

Set "Error Detective" as 1, Motor error appears, system will monitor and display on Hand-Set screen. This feature needs to be used together with motor "Error counter".

Set motor "error detection" as 2, take PI motor occurrence error as an example.

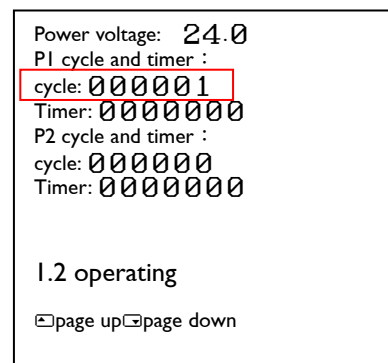
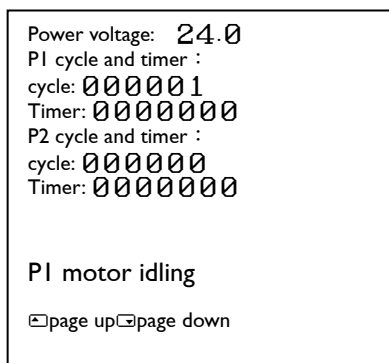
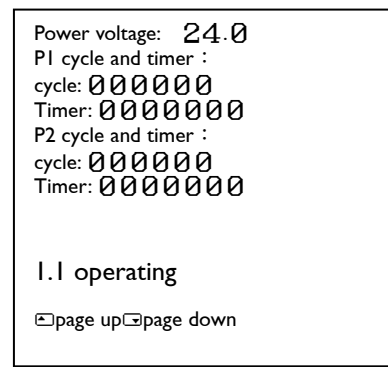
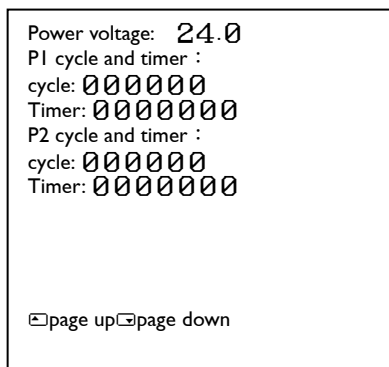

System detected PI motor idling and no. of motor errors reached 2. Lubricator stopped dispensing oil and system displayed an error message on screen.

System detected PI motor idling, but no. of motor errors did not reached 2. Lubricator continues dispensing oil and system will not display the error message on screen.



4.7 Lubricator Installation Procedure (TIMER mode I Control)

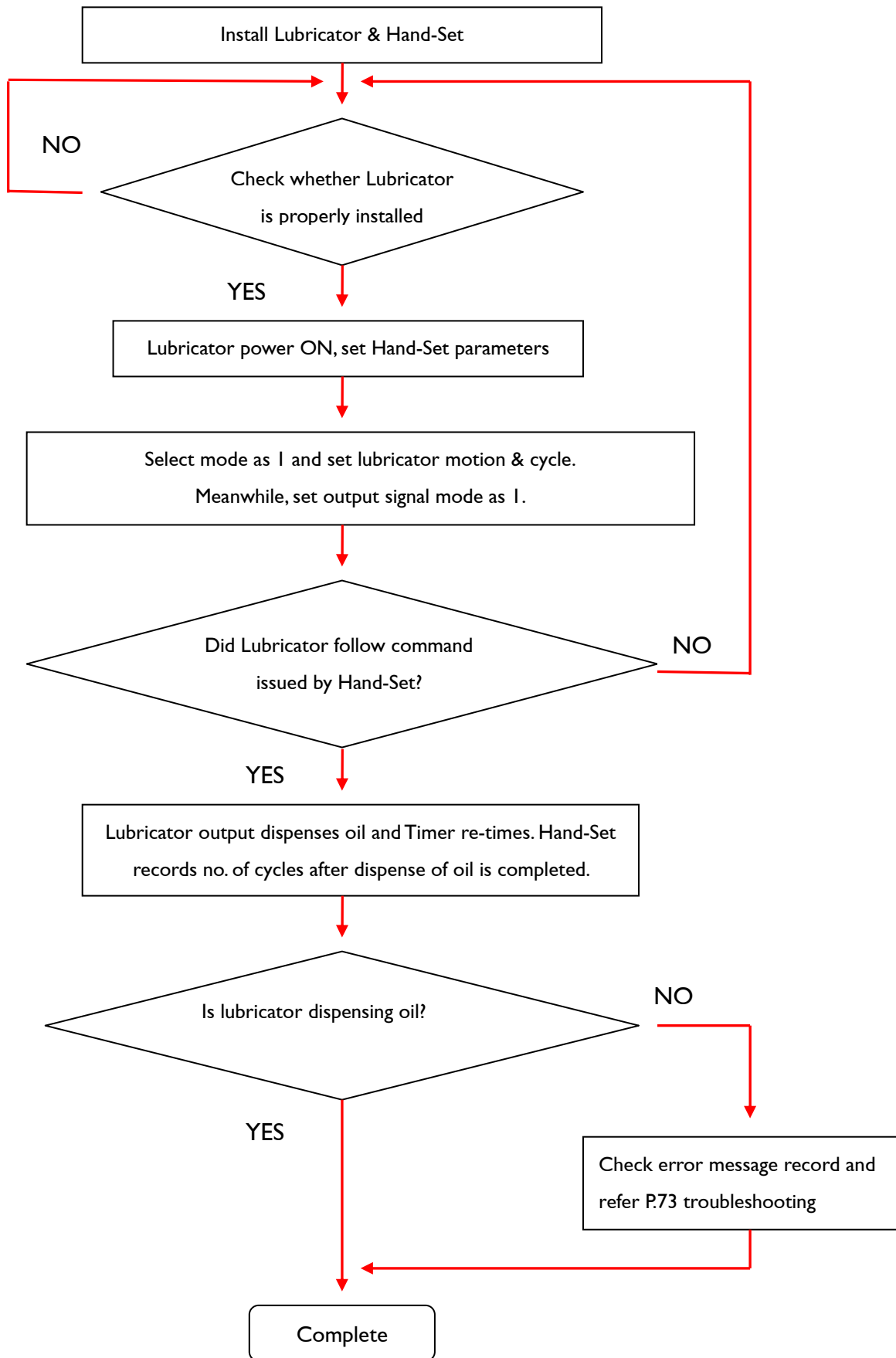



4.8 Lubricator Installation Procedure (PLC mode 2 Control)

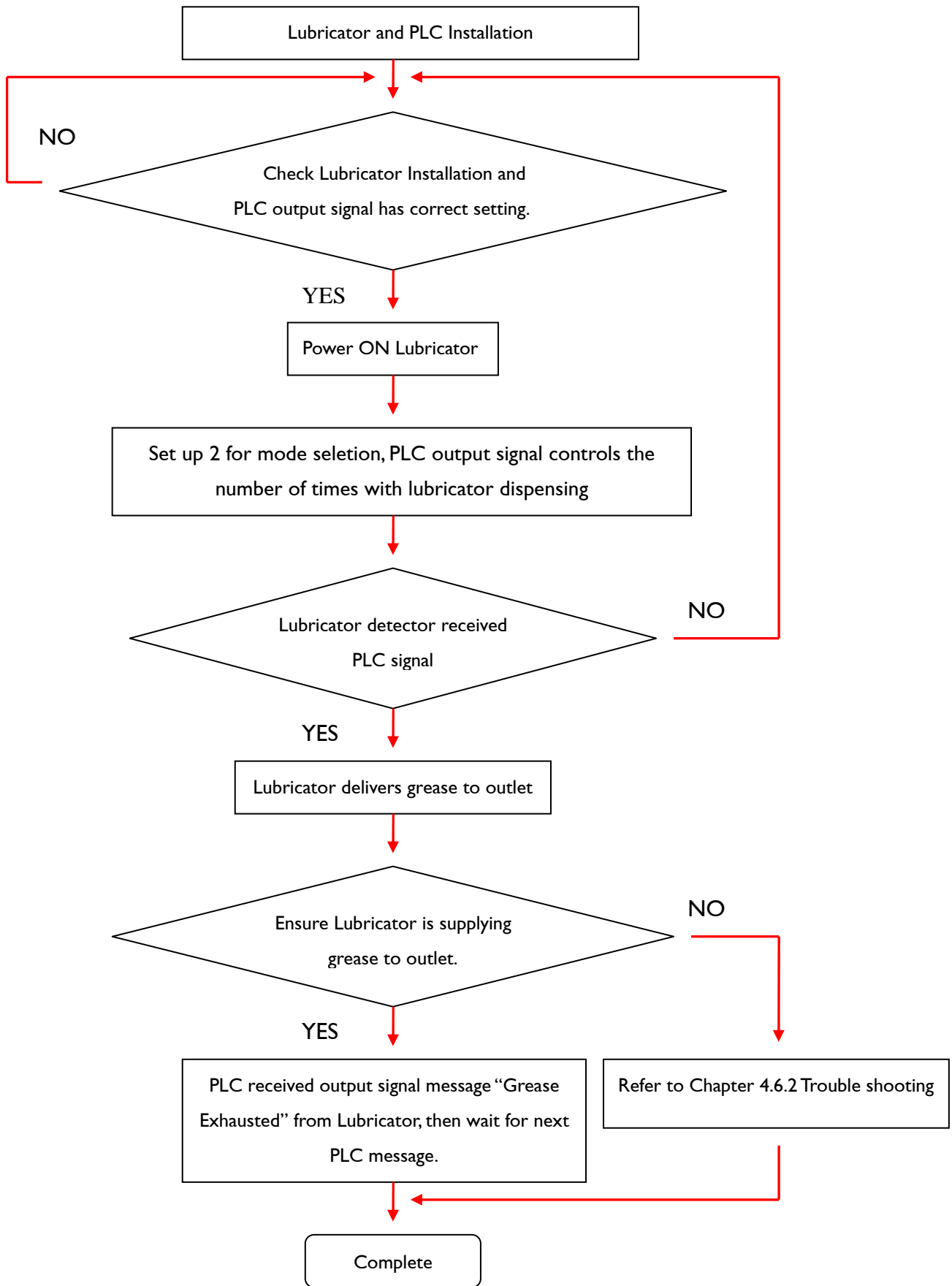



4.9 Instruction of Continuous Oil Dispensing.

After installing Lubricator PA tubes, user may press “PI ON” key function to allow lubricator to continuously dispense oil until empty PA tube is completely filled with oil and then press “PI OFF” key to stop dispensing oil. Lubricator with an excess air inside PA tubes, user may press “PI ON” key for continuous oil dispensing so as to discharge excess air that trapped inside the tube.

Description of Set-Up Example

(1) Press PI ON for continuous oil dispensing.

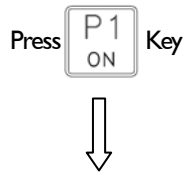

```

Power voltage: 24.0
P1 cycle and timer :
cycle: 000000
Timer: 00000000
P2 cycle and timer :
cycle: 000000
Timer: 00000000

I.1 operating
page up page down
  
```

Press “PI ON” key, PI outlet will dispense oil continuously.



```

Power voltage: 24.0
P1 cycle and timer :
cycle: 000001
Timer: 00000000
P2 cycle and timer :
cycle: 000000
Timer: 00000000

I.2 operating
page up page down
  
```





Power voltage: 24.0
 P1 cycle and timer :
 cycle: 000002
 Timer: 0000000
 P2 cycle and timer :
 cycle: 000000
 Timer: 0000000

1.1 operating

page up page down



Power voltage: 24.0
 P1 cycle and timer :
 cycle: 000003
 Timer: 0000000
 P2 cycle and timer :
 cycle: 000000
 Timer: 0000000

page up page down

Press “P1 OFF” key, Pump P1 outlet will stop dispensing oil.

(2) Press Pump P2 ON for continuous oil dispensing.



Power voltage: 24.0
 P1 cycle and timer :
 cycle: 000000
 Timer: 0000000
 P2 cycle and timer :
 cycle: 000000
 Timer: 0000000

2.1 operating

page up page down

Press “P2 ON” key, Pump P2 outlet will dispense oil continuously.





Power voltage: 24.0
 P1 cycle and timer :
 cycle: 000000
 Timer: 000000
 P2 cycle and timer :
 cycle: 000001
 Timer: 000000

2.2 operating

⏪page up⏩page down



Power voltage: 24.0
 P1 cycle and timer :
 cycle: 000000
 Timer: 000000
 P2 cycle and timer :
 cycle: 000002
 Timer: 000000

2.1 operating

⏪page up⏩page down



Press  Key

Power voltage: 24.0
 P1 cycle and timer :
 cycle: 000000
 Timer: 000000
 P2 cycle and timer :
 cycle: 000003
 Timer: 000000

⏪page up⏩page down

Press “P2 OFF” key, Pump P2 outlet will stop dispensing oil continuously.





(3) Press Pump P3 ON for continuous oil dispensing.

Press  Key



P3 cycle and timer :
 cycle: 000000
 Timer: 00000000
 P4 cycle and timer :
 cycle: 000000
 Timer: 00000000

3.1 operating



 page up  page down

Press “P3 ON” key, Pump P3 outlet will dispense oil continuously.



P3 cycle and timer :
 cycle: 000001
 Timer: 00000000
 P4 cycle and timer :
 cycle: 000000
 Timer: 00000000



3.2 operating

 page up  page down



P3 cycle and timer :
 cycle: 000002
 Timer: 00000000
 P4 cycle and timer :
 cycle: 000000
 Timer: 00000000

3.1 operating

 page up  page down

 Press  Key



P3 cycle and timer :
 cycle: 000003
 Timer: 0000000
 P4 cycle and timer :
 cycle: 000000
 Timer: 0000000

⏪ page up ⏩ page down

Press "P3OFF" key, Pump P3 outlet will stop dispensing oil continuously.

(4) Press Pump P4 ON for continuous oil dispensing.

Press  Key



P3 cycle and timer :
 cycle: 000000
 Timer: 0000000
 P4 cycle and timer :
 cycle: 000000
 Timer: 0000000

4.1 operating

⏪ page up ⏩ page down

Press "P4 ON" key, Pump P4 Outlet will dispense oil continuously.



P3 cycle and timer :
 cycle: 000000
 Timer: 0000000
 P4 cycle and timer :
 cycle: 000001
 Timer: 0000000

4.2 operating

⏪ page up ⏩ page down





P3 cycle and timer :
 cycle: 000000
 Timer: 00000000
 P4 cycle and timer :
 cycle: 000002
 Timer: 00000000

4.1 operating

⏪ page up ⏩ page down

↓ Press  Key

P3 cycle and timer :
 cycle: 000000
 Timer: 00000000
 P4 cycle and timer :
 cycle: 000003
 Timer: 00000000

⏪ page up ⏩ page down

Press “P4 OFF” key, Pump P4 outlet will stop dispensing oil continuously.

(5) Press Pump P5 on for continuous grease dispensing.

Press  Key

P5 cycle and timer :
 cycle: 000000
 Timer: 00000000

5.1 operating

⏪ page up ⏩ page down



Press “P5 ON” key, Pump P5 outlet will dispense oil continuously.



P5 cycle and timer :
cycle: 000001
Timer: 0000000

5.2 operating
page up page down



P5 cycle and timer :
cycle: 000002
Timer: 0000000

5.1 operating
page up page down



Press  Key

P5 cycle and timer :
cycle: 000003
Timer: 0000000

page up page down

Press "P5 OFF" key, Pump P5 outlet will stop dispensing oil continuously.



Appendix A Lubrication Setting

Due to various factors affecting the lubricator dispensing oil volume, APEX recommends the lubrication volume on catalog page 6 and each model lubricator setting method for reference.

Module No.	Average Speed	Output oil dispensing volume
5	1 m/s	0.3 cm ³ / 24h

AppendixA-I PLC mode 0 Control

For every 24 hours, PLC outputs the correct control signal to lubricator power plug PIN 2, Lubricator will dispense oil 0.3 cm³ / 24h at outlet. Each lubricator model's control signal is displayed as below:

AppendixA-I-1 Model LUG-2102

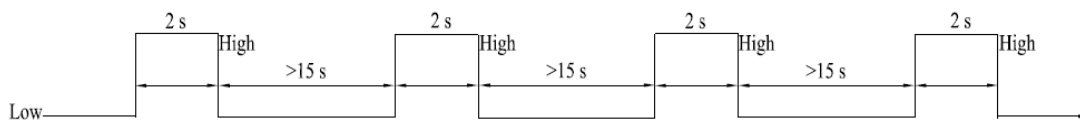

For every 24 hours, Lubricator received the PLC output signal above; outlet 1.1 and 1.2 will dispense two strokes individually with oil 0.3cm³.

AppendixA-I-2 Model LUG-2204

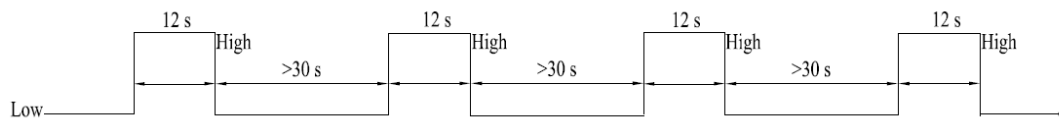

For every 24 hours, Lubricator received the PLC output signal above; outlet 1.1, 1.2, 2.1 and 2.2 will dispense two strokes individually with oil 0.3cm³.



AppendixA-I-3 Model LUG-2306

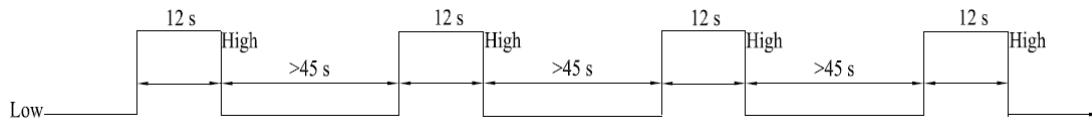

For every 24 hours, Lubricator received the PLC output signal above; outlet 1.1, 1.2, 2.1, 2.2, 3.1 and 3.2 will dispense two strokes individually with oil 0.3cm³.

AppendixA-I-4 Model LUG-2408

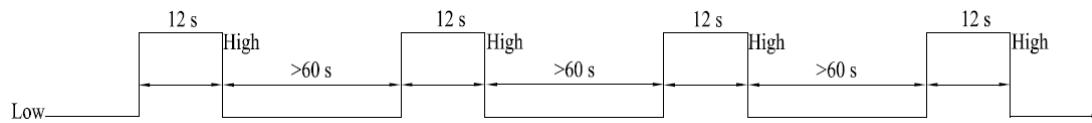

For every 24 hours, Lubricator received the PLC output signal above; outlet 1.1, 1.2, 2.1, 2.2, 3.1, 3.2, 4.1 and 4.2 will dispense two strokes individually with oil 0.3cm³.

AppendixA-I-5 Model LUG-2510

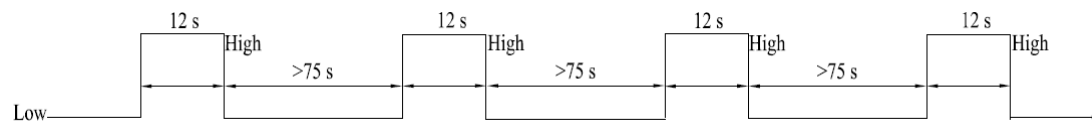

For every 24 hours, Lubricator received the PLC output signal above; outlet 1.1, 1.2, 2.1, 2.2, 3.1, 3.2, 4.1, 4.2, 5.1 and 5.2 will dispense two strokes individually with oil 0.3cm³.



AppendixA-2 TIMER Control

Lubricator control mode can be changed from selecting TIMER Mode in Hand-Set.
For every 24 hours, Lubricator will dispense oil 0.3 cm³ / 24h at output. An example illustrated below showing each lubricator model's operation.

AppendixA-2-1 Model LUG-2102

```

Mode Selection : 1
0:PLC 1:TIMER 2::PLC
PI cycle : 001 days
00 hours 00 minutes
PI motion : 04 times
P2 cycle : 000 days
00 hours 00 minutes
P2 motion : 01 times

page up page down

```

Set 1 in selection mode, Key in PI cycle 1 day and Key in PI motion 4 strokes. For every 24 hours, Lubricator outlet 1.1 and 1.2 will dispense 2 strokes with oil 0.3 cm³.

AppendixA-2-2 Model LUG-2204

```

Mode Selection : 1
0:PLC 1:TIMER 2::PLC
PI cycle : 001 days
00 hours 00 minutes
PI motion : 04 times
P2 cycle : 001 days
00 hours 00 minutes
P2 motion : 04 times

page up page down

```

Set 1 in selection mode, Key in PI and P2 cycle 1 day and Key in PI and P2 motion 4 strokes. For every 24 hours, Lubricator outlet 1.1, 1.2, 2.1 and 2.2 will dispense 2 strokes with oil 0.3 cm³.



AppendixA-2-3 Model LUG-2306

```

Mode Selection : 1
0:PLC 1:TIMER 2::PLC
P1 cycle : 001 days
00 hours 00 minutes
P1 motion : 04 times
P2 cycle : 001 days
00 hours 00 minutes
P2 motion : 04 times

page up page down

```



```

P3cycle : 001 days
00 hours 00 minutes
P3 motion : 04 times
P4 cycle : 000 days
00 hours 00 minutes
P4 motion : 01 times

page up page down

```

Set 1 in selection mode, Key in P1, P2 and P3 cycle 1 day and Key in P1, P2 and P3 motion 4 strokes. For every 24 hours, Lubricator outlet 1.1, 1.2, 2.1, 2.2, 3.1 and 3.2 will dispense 2 strokes with oil 0.3 cm³.

AppendixA-2-4 Model LUG-2408

```

Mode Selection : 1
0:PLC 1:TIMER 2::PLC
P1 cycle : 001 days
00 hours 00 minutes
P1 motion : 04 times
P2 cycle : 001 days
00 hours 00 minutes
P2 motion : 04 times

page up page down

```



```

P3cycle : 001 days
00 hours 00 minutes
P3 motion : 04 times
P4 cycle : 001 days
00 hours 00 minutes
P4 motion : 04 times

page up page down

```

Set 1 in selection mode, Key in P1, P2, P3 and P4 cycle 1 day and Key in P1, P2, P3 and P4 motion 4 strokes. For every 24 hours, Lubricator outlet 1.1, 1.2, 2.1, 2.2, 3.1, 3.2, 4.1 and 4.2 will dispense 2 strokes with oil 0.3 cm³.



AppendixA-2-5 Model LUG-2510

```

Mode Selection : 1
0:PLC 1:TIMER 2::PLC
P1 cycle : 001 days
00 hours 00 minutes
P1 motion : 04 times
P2 cycle : 001 days
00 hours 00 minutes
P2 motion : 04 times

page up page down

```

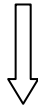

```

P3cycle : 001 days
00 hours 00 minutes
P3 motion : 04 times
P4 cycle : 001 days
00 hours 00 minutes
P4 motion : 04 times

page up page down

```



```

P5cycle : 001 days
00 hours 00 minutes
P5 motion : 04 times

page up page down

```

Set 1 in selection mode, Key in P1, P2, P3, P4 and P5 cycle 1 day and Key in P1, P2, P3, P4 and P5 motion 4 strokes. For every 24 hours, Lubricator outlet 1.1, 1.2, 2.1, 2.2, 3.1, 3.2, 4.1, 4.2, 5.1 and 5.2 will dispense 2 strokes with oil 0.3 cm³.



AppendixA-3 PLC mode 2 Control

Lubricator can dispense $0.3\text{cm}^3/24\text{h}$ oil when PLC output 24V signal to PIN 2 of lubricator for every 24 hours. The following are the signal waveform for each lubricator model:

AppendixA-3-1 Model LUG-2102

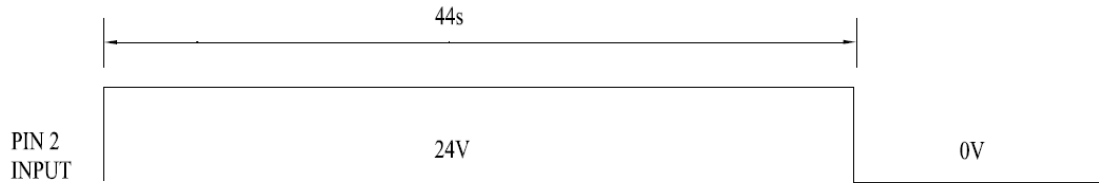

Lubricator outlet 1.1 and 1.2, will dispense 2 strokes with oil 0.3 cm^3 when lubricator receive the above signal from PLC for every 24 hours.

AppendixA-3-2 Model LUG-2204

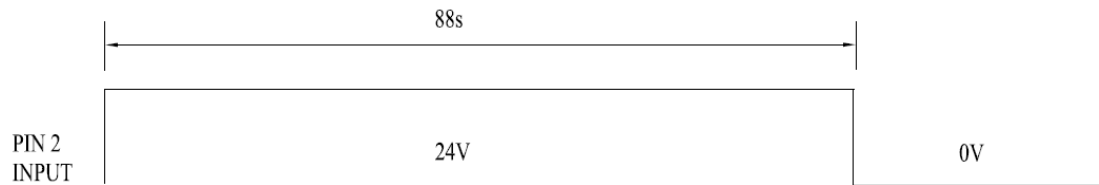

Lubricator outlet 1.1, 1.2, 2.1 and 2.2 will dispense 2 strokes with oil 0.3 cm^3 when lubricator receive the above signal from PLC for every 24 hours.



AppendixA-3-3 Model LUG-2306

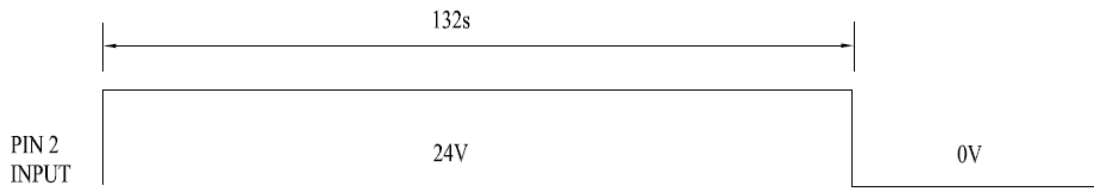

Lubricator outlet 1.1, 1.2, 2.1, 2.2, 3.1 and 3.2 will dispense 2 strokes with oil 0.3 cm³ when lubricator receive the above signal from PLC for every 24 hours.

AppendixA-3-4 Model LUG-2408

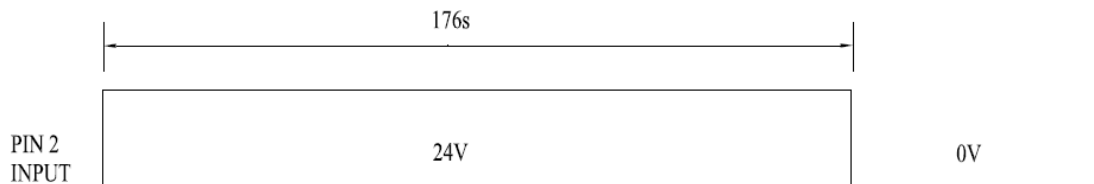

Lubricator outlet 1.1, 1.2, 2.1, 2.2, 3.1, 3.2, 4.1 and 4.2 will dispense 2 strokes with grease 0.3 cm³ when lubricator receive the above signal from PLC for every 24 hours.

AppendixA-3-5 Model LUG-2510

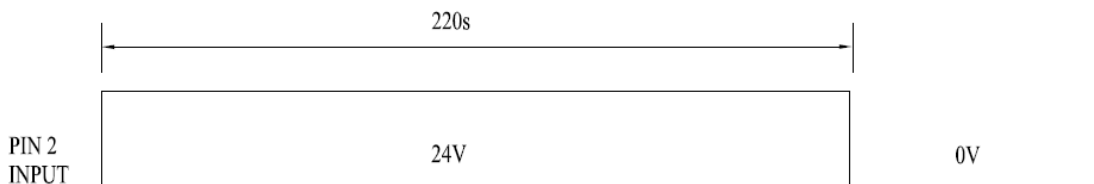

Lubricator outlet 1.1, 1.2, 2.1, 2.2, 3.1, 3.2, 4.1, 4.2, 5.1 and 5.2 will dispense 2 strokes with oil 0.3 cm³ when lubricator receive the above signal from PLC for every 24 hours.



Appendix B – Replenishing the oil to lubricator

STEP 1.

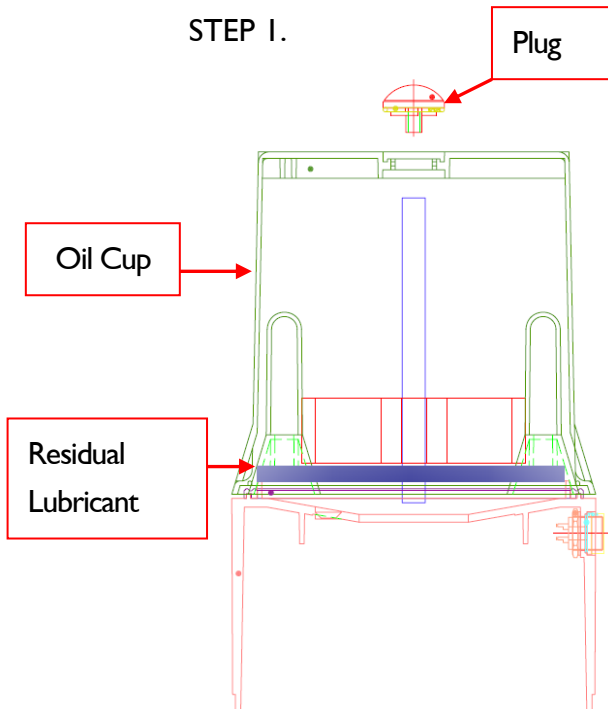

Turn off the power, remove the plug from the above of oil cup.

STEP 2.

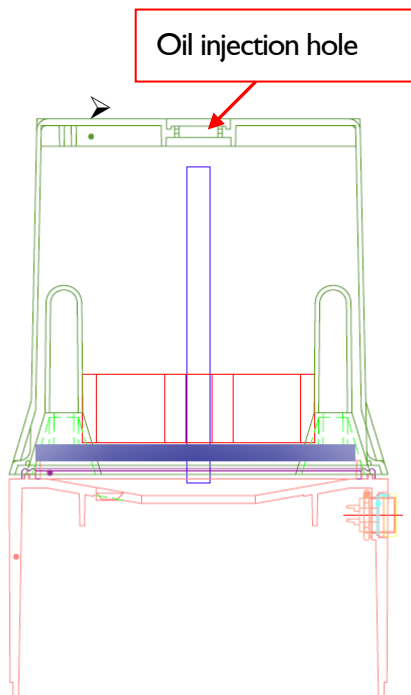

Replenish the oil from the oil injection hole

 **Caution**

	Use the funnel or assistant tool when inject the oil into the lubricator to avoid oil leakage to ground or equipment that cause the accident
	Wear personal protective equipment (Gloves)
	Wear personal protective equipment (Goggles)



STEP 3.

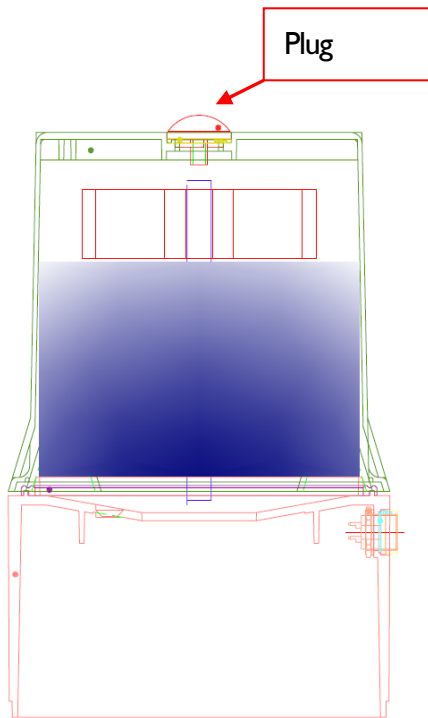

Replenishing completely, setup the plug before turn on the power

 Note



After replenishing of oil, be aware to re-screw the plug on the oil cup to avoid loose the plug



Appendix C- Lubricator Explosion Proof Specification

Lubricator explosion proof is not support to control by manual remote, which from the power cable and mention about all different meaning for each different colored wires. Therefore have to assembly and follow the sequence to process by appendix C-1. Set up for external ground request at least 8 AWG multi cores, to prevent static electricity and appear sparks.

Appendix C-1 side view and power cable wire connect description

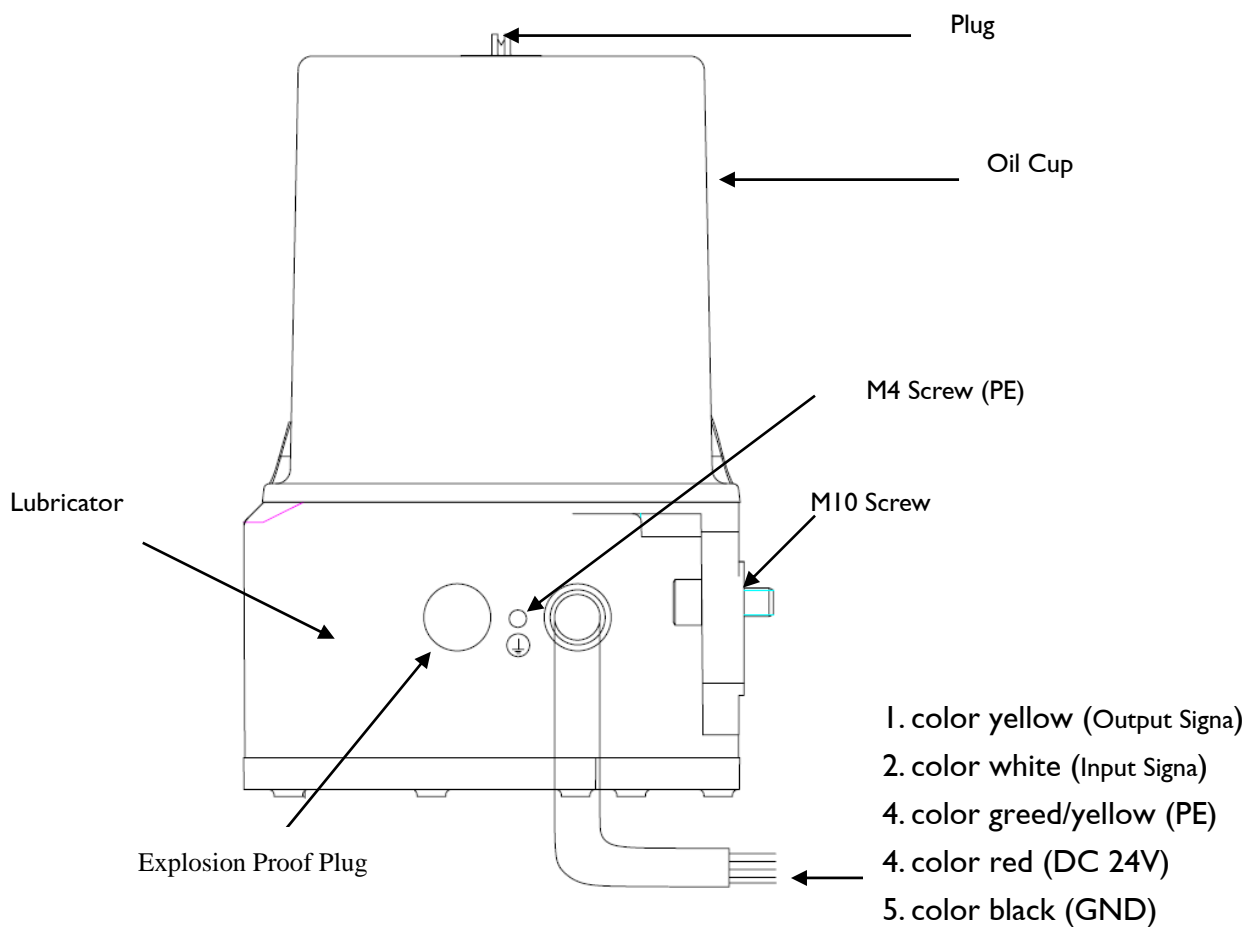



Appendix C-2 Maintenance and Storage

- Do not use a dry cloth to clean or maintain the machine body.
- Use extra caution during dry weather. Relative humidity tends to multiply the accumulation of static charges on any surface.
- Use the equipment only for its intended purpose.
- Incorrect or impermissible use or non-compliance with these instructions invalidates explosion protection.
- No changes to the equipment impairing its explosion protection are permitted.
- Excessive tightening of cable glands and stopping plugs can impair the degree of protection.
- Any damage can invalidate the Ex-protection.



1. WARNING – DO NOT OPEN WHEN AN EXPLOSIVE ATMOSPHERE IS PRESENT.
2. WARNING – POTENTIAL ELECTROSTATIC CHARGING HAZARD – SEE INSTRUCTIONS.
3. WARNING – CABLE GLAND FOR THE CABLES OF POWER CONNECTION OR SYSTEM SETUP SHOULD BE ATEX Ex e tc IP54 CERTIFIED WITH SUITABLE TEMPERATURE RATING.



II 3D Ex tc IIIB T80 C Dc IP5X