

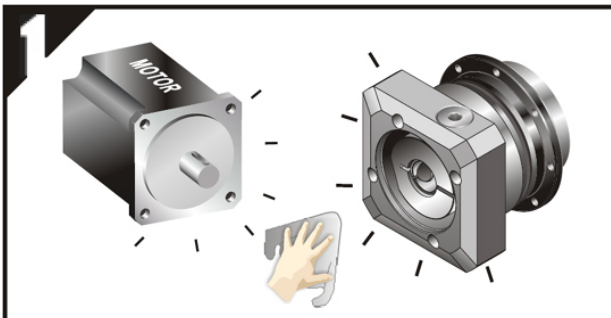

**MOTOR MOUNTING INSTRUCTION**

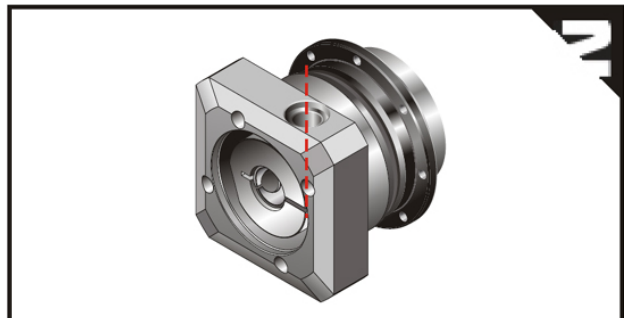

Double-check the motor and gearbox size  
Clean the mounting surface



Remove the plug on the adapter plate  
Rotate the set collar till the bolt is line up

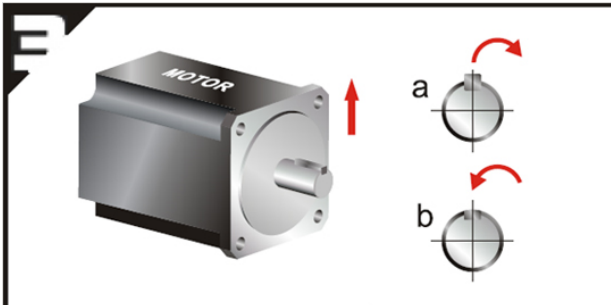

a Remove motor key  
b Insert balance key,  
if necessary

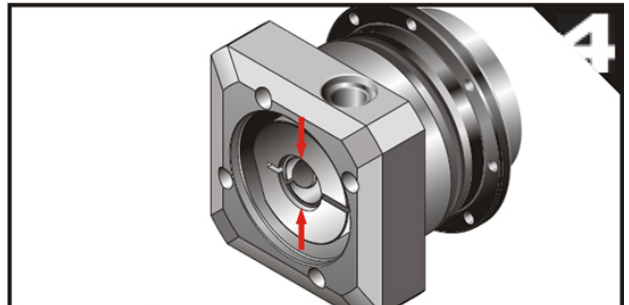

Check motor shaft size and insert  
bushing if necessary

**Correct Installation**

When installing on flatted shafts, be sure to align the collet gap over the flat and the set collar bolt perpendicular to the flat

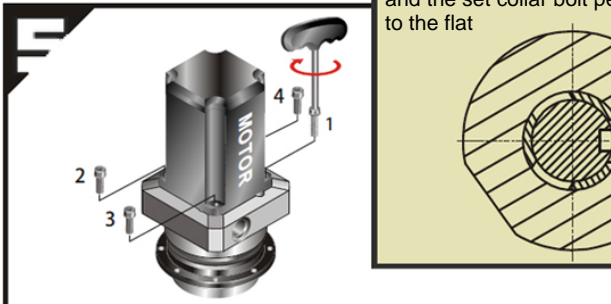

Set at vertical position, tighten the mounting bolts  
(including washer) in 1~4 order with wrench to 5%  
specified torque (see table 1)

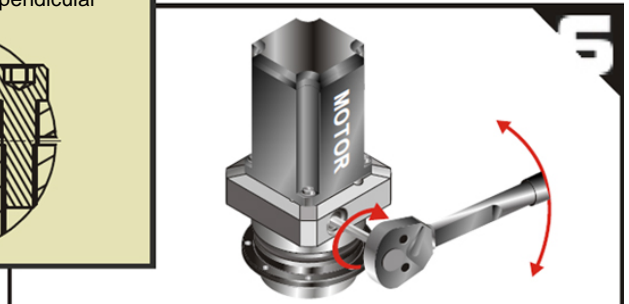

Tighten the set collar bolt with torque wrench to  
specified torque (see table 2)

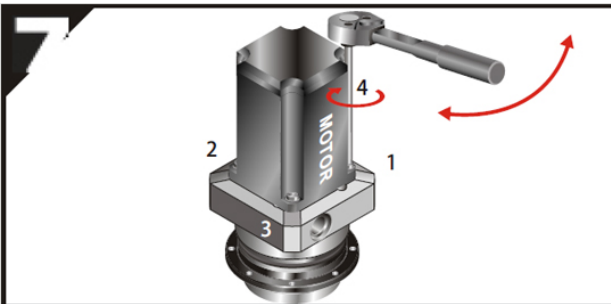

Tighten the mounting bolts in 1~4 order with torque  
wrench to specified torque (see table 1)

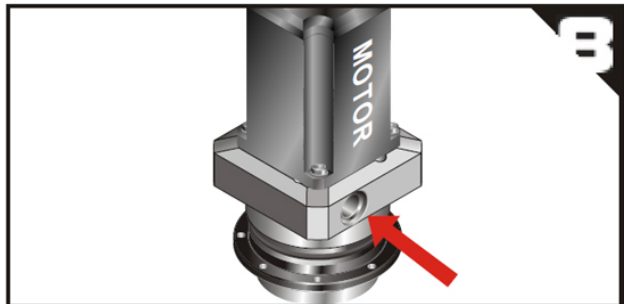

Tighten back the screw plug



**MOTOR MOUNTING INSTRUCTION**

**Table 1** Tightening torque recommended for motor mounting bolt

Bolt size	Width Across Flats	Strength 8.8 Tightening Torque		Strength 10.9 Tightening Torque		Strength 12.9 Tightening Torque	
	[mm]	[Nm]	[In-lbs]	[Nm]	[In-lbs]	[Nm]	[In-lbs]
M3 x 0.5P	2.5	1.3	12	1.8	16	2.1	19
M4 x 0.7P	3	3	27	4.1	37	4.9	44
M5 x 0.8P	4	6.1	55	8.2	73	9.8	87
M6 x 1P	5	11	98	14	124	17	151
M8 x 1.25P	6	25	222	34	302	41	364
M10 x 1.5P	8	49	434	67	594	80	709
M12 x 1.75P	10	85	753	116	1028	139	1232
M14 x 2P	12	137	1214	186	1648	223	1976
M16 x 2P	14	210	1860	286	2534	343	3038

**Table 2** Tightening torque recommended for set collar bolt

Gearbox size   Ø(C3)		8	11	14	19	24	28	32	35	38	42	48	55	60
AH064	1-stage	-	M5	M5	M6	-	-	-	-	-	-	-	-	-
	2-stage	M5	M5	M5	-	-	-	-	-	-	-	-	-	-
AH090	1-stage	-	-	M6	M6	M10	-	-	-	-	-	-	-	-
	2-stage	-	M5	M5	M6	-	-	-	-	-	-	-	-	-
AH110	1-stage	-	-	-	M8	M10	M10	M10	M12	M12	-	-	-	-
	2-stage	-	-	M6	M6	M10	-	-	-	-	-	-	-	-
AH140	1-stage	-	-	-	-	M10	M10	M10	M12	M12	M12	M16	-	-
	2-stage	-	-	-	M8	M10	M10	M10	M12	M12	-	-	-	-
AH200	1-stage	-	-	-	-	-	-	M10	M12	M12	M12	M16	-	-
	2-stage	-	-	-	-	M10	M10	M10	M12	M12	M12	M16	-	-
AH255	1-stage	-	-	-	-	-	-	-	M12	M12	M12	M16	M16	-
	2-stage	-	-	-	-	-	-	M10	M12	M12	M12	M16	-	-
AH285	1-stage	-	-	-	-	-	-	-	M12	M12	M12	M16	M16	M16
	2-stage	-	-	-	-	-	-	-	M12	M12	M12	M16	-	-
AH335	2-stage	-	-	-	-	-	-	-	-	M12	M12	M16	M16	-
AH450	2-stage	-	-	-	-	-	-	-	-	-	M12	M16	M16	M16

Bolt size	[mm]	M5 x 0.8P	M6 x 1P	M8 x 1.25P	M10 x 1.5P	M12 x 1.75P	M16 x 2P
Width Across Flats	[mm]	4	5	6	8	10	14
Tightening torque	[Nm]	9,8	17	41	80	139	343
	[In-lbs]	87	151	364	709	1232	3038

Note: Holding torques must be bigger than values shown above. Bolts can be tightened up to 20% higher for increased holding torques.

**Apex Dynamics bv**  
 Churchillaan 101  
 NL-5705 BK Helmond  
 The Netherlands  
 Tel. : +31 (0)492 509 995  
 Fax : +31 (0)492 509 997  
 E-mail : sales@apexdyna.nl

For more information, please visit our website: [www.apexdyna.nl](http://www.apexdyna.nl)

**High Precision Planetary Gearboxes**